

DINレール対応取付金具

金具型名	適合機種	電源取付ねじ	標準価格(税抜)
FD-A	RMB30A, RMC30A	M3 2本	¥650
FD-B	MMC8A RMB15A, RMC15A	M3 2本	¥650

DINレール
35mm幅対応

外形寸法

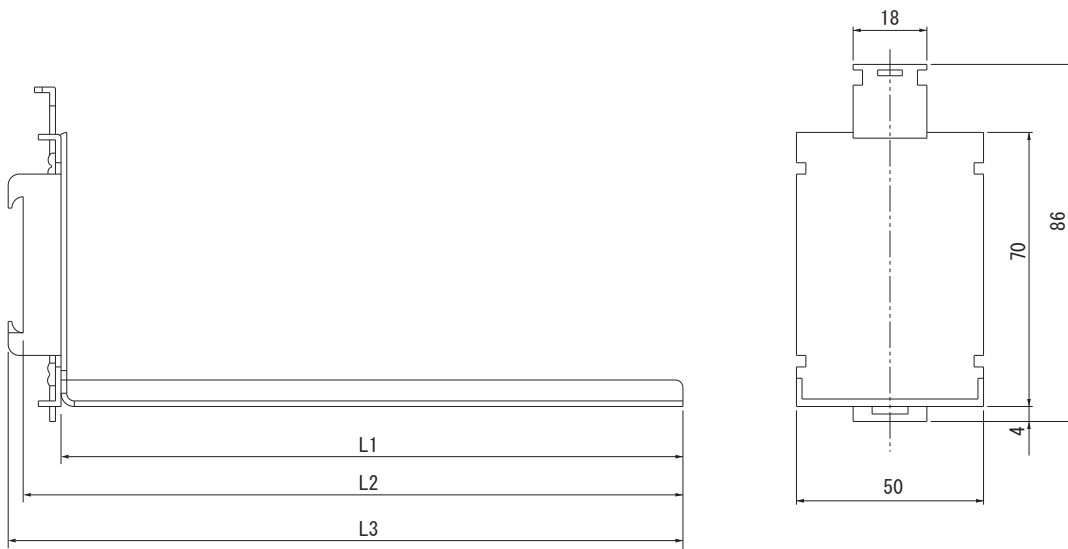

金具型名	L1	L2	L3
FD-A	165	174.5	178.6
FD-B	115	124.5	128.6

- ※材質：SPCC
- ※処理：三価クロメートメッキ
- ※板厚：1.6t
- ※一般公差：±1
- ※質量：FD-A 290g max
FD-B 240g max

DINレール対応取付金具
金具型名：FD-SP

取付例

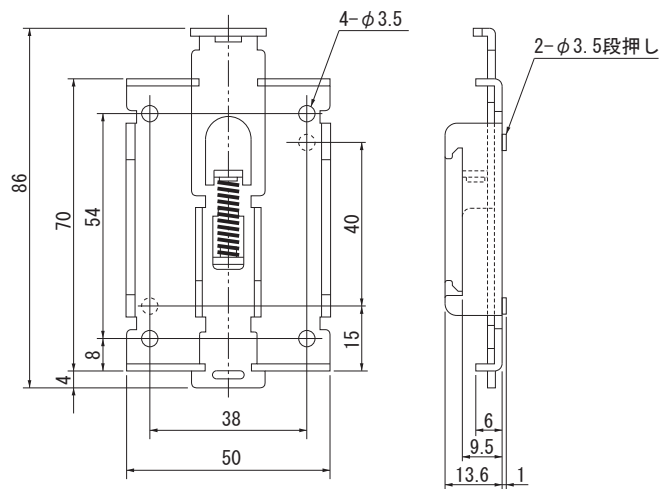
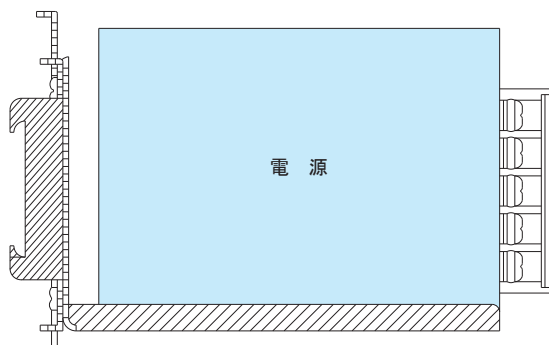

- ※材質：SPCC
- ※処理：三価クロメートメッキ
- ※板厚：1.6t
- ※一般公差：±1
- ※質量：85g max

★RMB/RMCシリーズは入出力のハーネス（-J仕様対応品）を用意しております。

例) RMB15A-1-J

RMBシリーズ
RMCシリーズ

適合ハーネス一覧

機種名	ハーネス型番	
	入力側	出力側
RMB15A, 30A, 50A	H-IN-3	H-OU-16
RMC15A, 30A, 50A		H-OU-15

			標準価格(税抜)																																															
<p>●型番</p> <p>H-IN-3</p> <p>ハウジング：VHR-5N（日本圧着端子） 接 触 子：SVH-21T-P1.1 （日本圧着端子） 質 量：20g max</p>	<p>●形状</p>	<p>●使用電線</p> <table border="1"> <thead> <tr> <th>コネクタ ピン番号</th> <th>電線番号</th> <th>AWG</th> <th>色</th> <th>長さ ℓ [mm]</th> </tr> </thead> <tbody> <tr> <td>1</td> <td>UL1015</td> <td>20</td> <td>白</td> <td>500</td> </tr> <tr> <td>2</td> <td>あきピン</td> <td></td> <td></td> <td></td> </tr> <tr> <td>3</td> <td>UL1015</td> <td>20</td> <td>黒</td> <td>500</td> </tr> <tr> <td>4</td> <td>あきピン</td> <td></td> <td></td> <td></td> </tr> <tr> <td>5</td> <td>UL1015</td> <td>20</td> <td>緑</td> <td>500</td> </tr> </tbody> </table>	コネクタ ピン番号	電線番号	AWG	色	長さ ℓ [mm]	1	UL1015	20	白	500	2	あきピン				3	UL1015	20	黒	500	4	あきピン				5	UL1015	20	緑	500	¥110																	
コネクタ ピン番号	電線番号	AWG	色	長さ ℓ [mm]																																														
1	UL1015	20	白	500																																														
2	あきピン																																																	
3	UL1015	20	黒	500																																														
4	あきピン																																																	
5	UL1015	20	緑	500																																														
<p>●型番</p> <p>H-OU-15</p> <p>ハウジング：VHR-8N（日本圧着端子） 接 触 子：SVH-21T-P1.1 （日本圧着端子） 質 量：80g max</p>	<p>●形状</p>	<p>●使用電線</p> <table border="1"> <thead> <tr> <th>コネクタ ピン番号</th> <th>電線番号</th> <th>AWG</th> <th>色</th> <th>長さ ℓ [mm]</th> </tr> </thead> <tbody> <tr> <td>1</td> <td>UL1015</td> <td>18</td> <td>紫</td> <td>500</td> </tr> <tr> <td>2</td> <td>UL1015</td> <td>18</td> <td>灰</td> <td>500</td> </tr> <tr> <td>3</td> <td>UL1015</td> <td>18</td> <td>灰</td> <td>500</td> </tr> <tr> <td>4</td> <td>UL1015</td> <td>18</td> <td>橙</td> <td>500</td> </tr> <tr> <td>5</td> <td>UL1015</td> <td>18</td> <td>黒</td> <td>500</td> </tr> <tr> <td>6</td> <td>UL1015</td> <td>18</td> <td>黒</td> <td>500</td> </tr> <tr> <td>7</td> <td>UL1015</td> <td>18</td> <td>赤</td> <td>500</td> </tr> <tr> <td>8</td> <td>UL1015</td> <td>18</td> <td>赤</td> <td>500</td> </tr> </tbody> </table>	コネクタ ピン番号	電線番号	AWG	色	長さ ℓ [mm]	1	UL1015	18	紫	500	2	UL1015	18	灰	500	3	UL1015	18	灰	500	4	UL1015	18	橙	500	5	UL1015	18	黒	500	6	UL1015	18	黒	500	7	UL1015	18	赤	500	8	UL1015	18	赤	500	¥400		
コネクタ ピン番号	電線番号	AWG	色	長さ ℓ [mm]																																														
1	UL1015	18	紫	500																																														
2	UL1015	18	灰	500																																														
3	UL1015	18	灰	500																																														
4	UL1015	18	橙	500																																														
5	UL1015	18	黒	500																																														
6	UL1015	18	黒	500																																														
7	UL1015	18	赤	500																																														
8	UL1015	18	赤	500																																														
<p>●型番</p> <p>H-OU-16</p> <p>ハウジング：VHR-6N（日本圧着端子） 接 触 子：SVH-21T-P1.1 （日本圧着端子） 質 量：60g max</p>	<p>●形状</p>	<p>●使用電線</p> <table border="1"> <thead> <tr> <th>コネクタ ピン番号</th> <th>電線番号</th> <th>AWG</th> <th>色</th> <th>長さ ℓ [mm]</th> </tr> </thead> <tbody> <tr> <td>1</td> <td>UL1015</td> <td>18</td> <td>灰</td> <td>500</td> </tr> <tr> <td>2</td> <td>UL1015</td> <td>18</td> <td>橙</td> <td>500</td> </tr> <tr> <td>3</td> <td>UL1015</td> <td>18</td> <td>黒</td> <td>500</td> </tr> <tr> <td>4</td> <td>UL1015</td> <td>18</td> <td>黒</td> <td>500</td> </tr> <tr> <td>5</td> <td>UL1015</td> <td>18</td> <td>赤</td> <td>500</td> </tr> <tr> <td>6</td> <td>UL1015</td> <td>18</td> <td>赤</td> <td>500</td> </tr> </tbody> </table>	コネクタ ピン番号	電線番号	AWG	色	長さ ℓ [mm]	1	UL1015	18	灰	500	2	UL1015	18	橙	500	3	UL1015	18	黒	500	4	UL1015	18	黒	500	5	UL1015	18	赤	500	6	UL1015	18	赤	500	¥300												
コネクタ ピン番号	電線番号	AWG	色	長さ ℓ [mm]																																														
1	UL1015	18	灰	500																																														
2	UL1015	18	橙	500																																														
3	UL1015	18	黒	500																																														
4	UL1015	18	黒	500																																														
5	UL1015	18	赤	500																																														
6	UL1015	18	赤	500																																														