

DATA SHEET		Date	12-Sep-17
Model	TUHS25F15	Temp.	25 degreeC
Test	EMI Line conduction & Radiated emission	Humid.	40 %RH
		Tested by	T.Sakuma

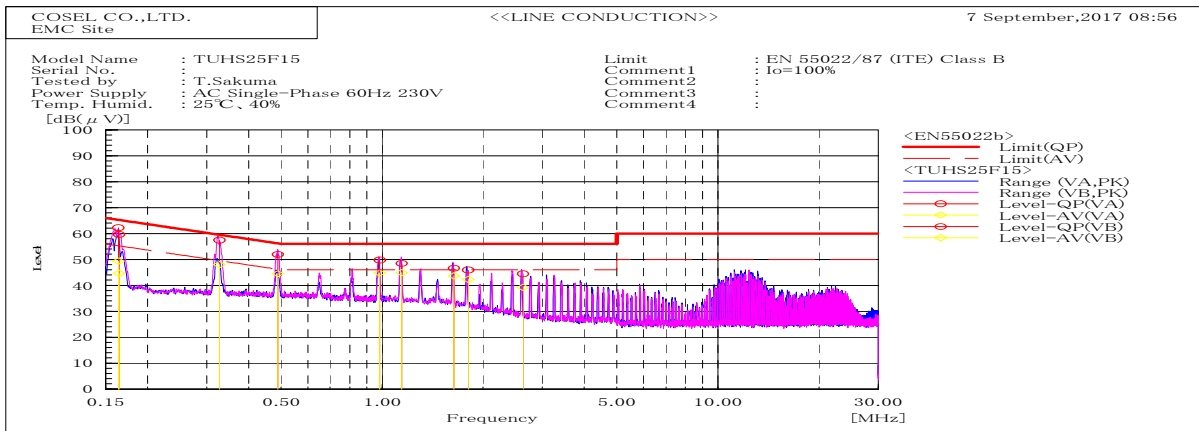

Frequency MHz	Harm	Line Phase	Reading dB(uV)		Factor dB	Level dB(uV/m)		Limit dB(uV/m)		Margin dB		Pass/Fail	Remark
			QP	AV		QP	AV	QP	AV	QP	AV		
0.16384		VB	41.3	28.4	21.0	62.3	49.4	65.3	55.3	3.0	5.9	Pass	
0.16444		VA	38.6	23.6	21.0	59.6	44.6	65.2	55.2	5.6	10.6	Pass	
0.32729		VB	36.6	27.1	20.9	57.5	48.0	59.5	49.5	2.0	1.5	Pass	
0.48873		VB	31.0	23.5	20.9	51.9	44.4	56.2	46.2	4.3	1.8	Pass	
0.98227		VB	28.9	23.9	20.9	49.8	44.8	56.0	46.0	6.2	1.2	Pass	
1.14269		VA	27.4	23.9	21.0	48.4	44.9	56.0	46.0	7.6	1.1	Pass	
1.6363		VA	25.6	22.7	21.0	46.6	43.7	56.0	46.0	9.4	2.3	Pass	
1.8041		VA	24.8	21.2	21.1	45.9	42.3	56.0	46.0	10.1	3.7	Pass	
2.62194		VA	23.4	18.1	21.1	44.5	39.2	56.0	46.0	11.5	6.8	Pass	

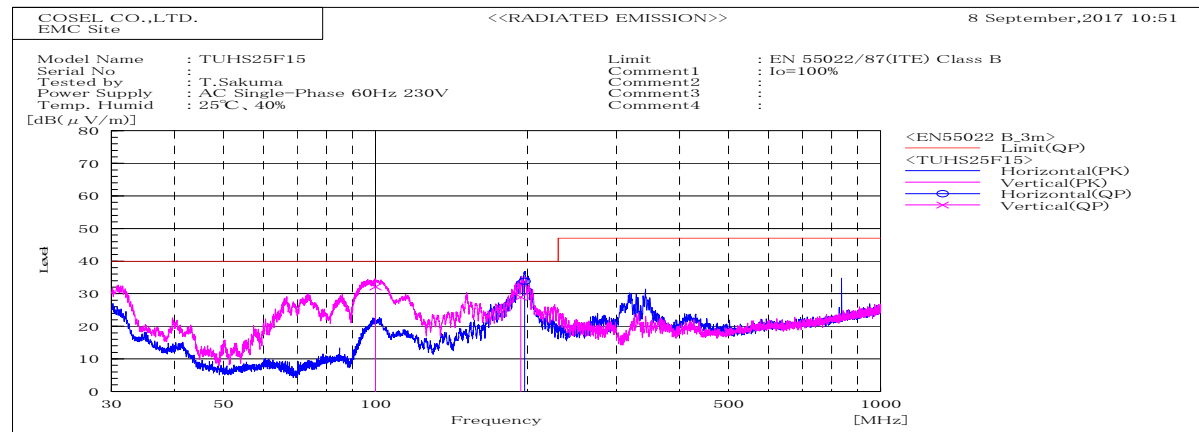

Frequency MHz	Polarization	Stability	Reading dB(uV)		Factor dB(1/m)	Level dB(uV/m)		Limit dB(uV/m)		Margin dB		Pass/Fail	Height cm	Angle deg	Remark
			QP	AV		QP	AV	QP	AV						
99.947	V	Stable	47.6		-15.5	32.1		40.0		7.9		Pass	105	14	
193.920	V	Stable	40.9		-11.9	29.0		40.0		11.0		Pass	127	147	
197.388	H	Stable	45.8		-12.0	33.8		40.0		6.2		Pass	149	1	

DATA SHEET		Date	12-Sep-17
Model	Circuit used for measurement	Temp.	25 degreeC
Test	EMI Line conduction & Radiated emission	Humid.	40 %RH
		Tested by	T.Sakuma

1. Line conduction

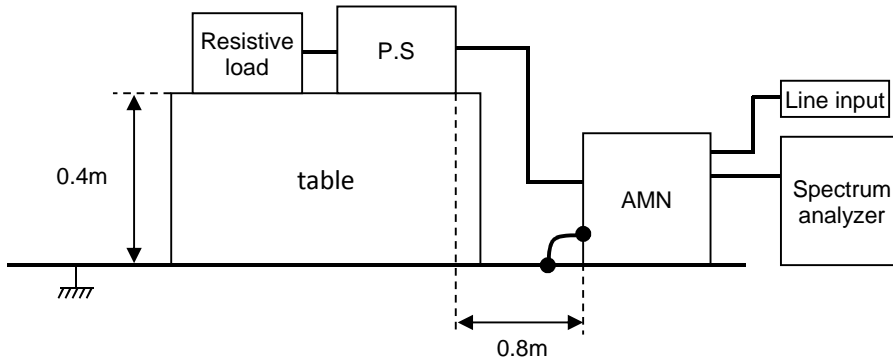

2. Radiated emission

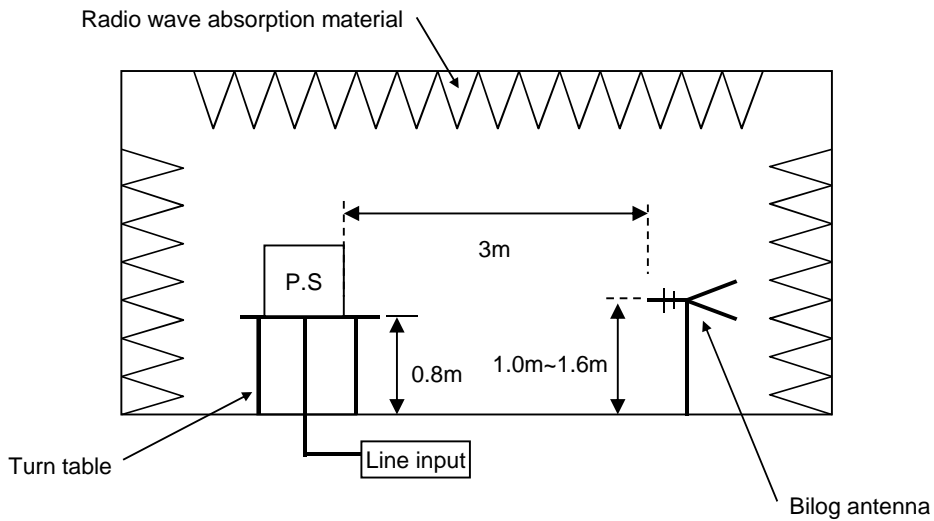

Conditions

Test: EMI
 Model Name: TUHS25F15

- Photographs of Test Set-Up

LINE CONDUCTION



RADIATED EMISSION

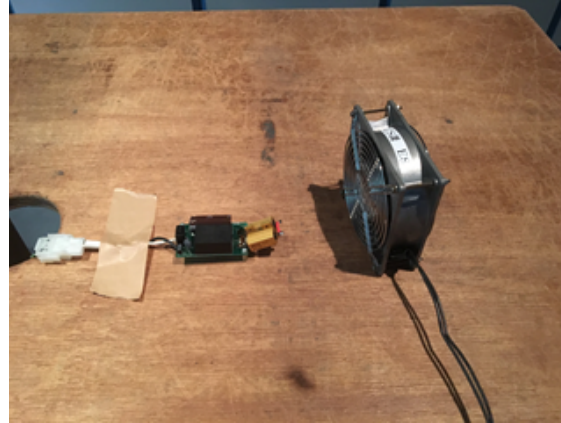

- Test circuit

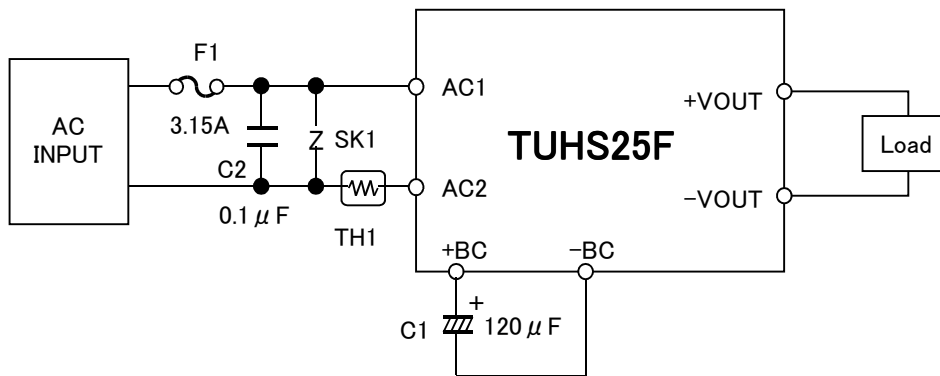

- | | | |
|------|------------------------------|-------|
| F1: | SLT250V3.15A (Nippon Seisen) | 3.15A |
| TH1: | 10D2-08LCS (SEMITEC) | 10 Ω |
| SK1: | S10K385E2K1 (TDK EPCOS) | |

Fig.1 Testing circuitry