

# TEST DATA OF MGS15243R3

Regulated DC Power Supply  
September 9, 2010

Approved by : *Kazunari Asano*  
Kazunari Asano Design Manager

Prepared by : *Junki Nakayama*  
Junki Nakayama Design Engineer

**COSEL CO.,LTD.**

## CONTENTS

1.Input Current (by Input Voltage) . . . . .	1
2.Input Current (by Load Current) . . . . .	2
3.Input Power (by Load Current) . . . . .	3
4.Efficiency (by Input Voltage) . . . . .	4
5.Efficiency (by Load Current) . . . . .	5
6.Line Regulation . . . . .	6
7.Load Regulation . . . . .	7
8.Dynamic Load Response . . . . .	8
9.Ripple Voltage (by Load Current) . . . . .	9
10.Ripple-Noise . . . . .	10
11.Ripple Voltage (by Ambient Temperature) . . . . .	11
12.Ambient Temperature Drift . . . . .	12
13.Output Voltage Accuracy . . . . .	13
14.Time Lapse Drift . . . . .	14
15.Rise and Fall Time . . . . .	15
16.Minimum Input Voltage for Regulated Output Voltage . . . . .	16
17.Overcurrent Protection . . . . .	17
18.Figure of Testing Circuitry . . . . .	18

(Final Page 18)



<p>Model MGS15243R3</p> <p>Item Input Current (by Input Voltage)</p> <p>Object _____</p>		<p>Temperature 25°C</p> <p>Testing Circuitry Figure A</p>																																																																															
<p>1.Graph</p> <p> <span style="display: inline-block; width: 1em; border-bottom: 1px solid black; margin-right: 0.5em;"></span> <span style="display: inline-block; width: 1em; border-bottom: 1px dashed black; margin-right: 0.5em;"></span> <span style="display: inline-block; width: 1em; border-bottom: 1px dash-dot black; margin-right: 0.5em;"></span> </p> <p> <span style="display: inline-block; width: 1em; border-bottom: 1px solid black; margin-right: 0.5em;"></span> △ Load 100%</p> <p> <span style="display: inline-block; width: 1em; border-bottom: 1px dashed black; margin-right: 0.5em;"></span> □ Load 50%</p> <p> <span style="display: inline-block; width: 1em; border-bottom: 1px dash-dot black; margin-right: 0.5em;"></span> ○ Load 0%</p>		<p>2.Values</p>																																																																															
		<table border="1"> <thead> <tr> <th rowspan="2">Input Voltage [V]</th> <th colspan="3">Input Current [A]</th> </tr> <tr> <th>Load 0%</th> <th>Load 50%</th> <th>Load 100%</th> </tr> </thead> <tbody> <tr><td>0</td><td>0.000</td><td>0.000</td><td>0.000</td></tr> <tr><td>4</td><td>0.001</td><td>0.002</td><td>0.001</td></tr> <tr><td>8</td><td>0.002</td><td>0.002</td><td>0.002</td></tr> <tr><td>16</td><td>0.003</td><td>0.003</td><td>0.003</td></tr> <tr><td>17</td><td>0.041</td><td>0.467</td><td>0.940</td></tr> <tr><td>18</td><td>0.040</td><td>0.433</td><td>0.864</td></tr> <tr><td>20</td><td>0.038</td><td>0.390</td><td>0.777</td></tr> <tr><td>22</td><td>0.035</td><td>0.355</td><td>0.704</td></tr> <tr><td>24</td><td>0.033</td><td>0.326</td><td>0.644</td></tr> <tr><td>28</td><td>0.030</td><td>0.280</td><td>0.550</td></tr> <tr><td>30</td><td>0.029</td><td>0.262</td><td>0.515</td></tr> <tr><td>32</td><td>0.028</td><td>0.247</td><td>0.481</td></tr> <tr><td>36</td><td>0.026</td><td>0.220</td><td>0.429</td></tr> <tr><td>40</td><td>0.025</td><td>0.199</td><td>0.387</td></tr> <tr><td>--</td><td>-</td><td>-</td><td>-</td></tr> <tr><td>--</td><td>-</td><td>-</td><td>-</td></tr> <tr><td>--</td><td>-</td><td>-</td><td>-</td></tr> <tr><td>--</td><td>-</td><td>-</td><td>-</td></tr> </tbody> </table>	Input Voltage [V]	Input Current [A]			Load 0%	Load 50%	Load 100%	0	0.000	0.000	0.000	4	0.001	0.002	0.001	8	0.002	0.002	0.002	16	0.003	0.003	0.003	17	0.041	0.467	0.940	18	0.040	0.433	0.864	20	0.038	0.390	0.777	22	0.035	0.355	0.704	24	0.033	0.326	0.644	28	0.030	0.280	0.550	30	0.029	0.262	0.515	32	0.028	0.247	0.481	36	0.026	0.220	0.429	40	0.025	0.199	0.387	--	-	-	-	--	-	-	-	--	-	-	-	--	-	-	-
Input Voltage [V]	Input Current [A]																																																																																
	Load 0%	Load 50%	Load 100%																																																																														
0	0.000	0.000	0.000																																																																														
4	0.001	0.002	0.001																																																																														
8	0.002	0.002	0.002																																																																														
16	0.003	0.003	0.003																																																																														
17	0.041	0.467	0.940																																																																														
18	0.040	0.433	0.864																																																																														
20	0.038	0.390	0.777																																																																														
22	0.035	0.355	0.704																																																																														
24	0.033	0.326	0.644																																																																														
28	0.030	0.280	0.550																																																																														
30	0.029	0.262	0.515																																																																														
32	0.028	0.247	0.481																																																																														
36	0.026	0.220	0.429																																																																														
40	0.025	0.199	0.387																																																																														
--	-	-	-																																																																														
--	-	-	-																																																																														
--	-	-	-																																																																														
--	-	-	-																																																																														
<p>Note: Slanted line shows the range of the rated input voltage.</p>																																																																																	



Model		MGS15243R3		Temperature 25°C																																																				
Item		Input Current (by Load Current)		Testing Circuitry Figure A																																																				
Object		_____																																																						
1.Graph		—△— Input Volt. 18V - - - □ - - - Input Volt. 24V - · - ○ - · - - Input Volt. 36V		2.Values																																																				
				<table border="1"> <thead> <tr> <th rowspan="2">Load Current [A]</th> <th colspan="3">Input Current [A]</th> </tr> <tr> <th>Input Volt. 18[V]</th> <th>Input Volt. 24[V]</th> <th>Input Volt. 36[V]</th> </tr> </thead> <tbody> <tr><td>0.0</td><td>0.040</td><td>0.034</td><td>0.026</td></tr> <tr><td>0.8</td><td>0.194</td><td>0.148</td><td>0.103</td></tr> <tr><td>1.6</td><td>0.354</td><td>0.267</td><td>0.181</td></tr> <tr><td>2.4</td><td>0.517</td><td>0.390</td><td>0.263</td></tr> <tr><td>3.2</td><td>0.693</td><td>0.516</td><td>0.344</td></tr> <tr><td>4.0</td><td>0.866</td><td>0.642</td><td>0.429</td></tr> <tr><td>4.4</td><td>0.954</td><td>0.715</td><td>0.473</td></tr> <tr><td>--</td><td>-</td><td>-</td><td>-</td></tr> <tr><td>--</td><td>-</td><td>-</td><td>-</td></tr> <tr><td>--</td><td>-</td><td>-</td><td>-</td></tr> <tr><td>--</td><td>-</td><td>-</td><td>-</td></tr> </tbody> </table>		Load Current [A]	Input Current [A]			Input Volt. 18[V]	Input Volt. 24[V]	Input Volt. 36[V]	0.0	0.040	0.034	0.026	0.8	0.194	0.148	0.103	1.6	0.354	0.267	0.181	2.4	0.517	0.390	0.263	3.2	0.693	0.516	0.344	4.0	0.866	0.642	0.429	4.4	0.954	0.715	0.473	--	-	-	-	--	-	-	-	--	-	-	-	--	-	-	-
Load Current [A]	Input Current [A]																																																							
	Input Volt. 18[V]	Input Volt. 24[V]	Input Volt. 36[V]																																																					
0.0	0.040	0.034	0.026																																																					
0.8	0.194	0.148	0.103																																																					
1.6	0.354	0.267	0.181																																																					
2.4	0.517	0.390	0.263																																																					
3.2	0.693	0.516	0.344																																																					
4.0	0.866	0.642	0.429																																																					
4.4	0.954	0.715	0.473																																																					
--	-	-	-																																																					
--	-	-	-																																																					
--	-	-	-																																																					
--	-	-	-																																																					
Note: Slanted line shows the range of the rated load current.																																																								



<b>COSEL</b>																																																						
Model	MGS15243R3	Temperature	25°C																																																			
Item	Input Power (by Load Current)	Testing Circuitry	Figure A																																																			
Object	_____																																																					
<p>1.Graph</p> <p> <span style="display: inline-block; width: 10px; border-bottom: 1px solid black; margin-right: 5px;"></span> <span style="display: inline-block; width: 10px; border-bottom: 1px dashed black; margin-right: 5px;"></span> <span style="display: inline-block; width: 10px; border-bottom: 1px dash-dot black; margin-right: 5px;"></span> </p> <p> <span style="display: inline-block; width: 10px; border-bottom: 1px solid black; margin-right: 5px;"></span> △ — Input Volt. 18V  <span style="display: inline-block; width: 10px; border-bottom: 1px dashed black; margin-right: 5px;"></span> □ - - Input Volt. 24V  <span style="display: inline-block; width: 10px; border-bottom: 1px dash-dot black; margin-right: 5px;"></span> ○ - · - Input Volt. 36V                 </p>		<p>2.Values</p>																																																				
		<table border="1"> <thead> <tr> <th rowspan="2">Load Current [A]</th> <th colspan="3">Input Power [W]</th> </tr> <tr> <th>Input Volt. 18[V]</th> <th>Input Volt. 24[V]</th> <th>Input Volt. 36[V]</th> </tr> </thead> <tbody> <tr><td>0.0</td><td>0.72</td><td>0.81</td><td>0.95</td></tr> <tr><td>0.8</td><td>3.47</td><td>3.55</td><td>3.69</td></tr> <tr><td>1.6</td><td>6.35</td><td>6.39</td><td>6.52</td></tr> <tr><td>2.4</td><td>9.33</td><td>9.34</td><td>9.44</td></tr> <tr><td>3.2</td><td>12.34</td><td>12.31</td><td>12.35</td></tr> <tr><td>4.0</td><td>15.55</td><td>15.44</td><td>15.41</td></tr> <tr><td>4.4</td><td>17.22</td><td>17.03</td><td>16.97</td></tr> <tr><td>--</td><td>-</td><td>-</td><td>-</td></tr> <tr><td>--</td><td>-</td><td>-</td><td>-</td></tr> <tr><td>--</td><td>-</td><td>-</td><td>-</td></tr> <tr><td>--</td><td>-</td><td>-</td><td>-</td></tr> </tbody> </table>		Load Current [A]	Input Power [W]			Input Volt. 18[V]	Input Volt. 24[V]	Input Volt. 36[V]	0.0	0.72	0.81	0.95	0.8	3.47	3.55	3.69	1.6	6.35	6.39	6.52	2.4	9.33	9.34	9.44	3.2	12.34	12.31	12.35	4.0	15.55	15.44	15.41	4.4	17.22	17.03	16.97	--	-	-	-	--	-	-	-	--	-	-	-	--	-	-	-
Load Current [A]	Input Power [W]																																																					
	Input Volt. 18[V]	Input Volt. 24[V]	Input Volt. 36[V]																																																			
0.0	0.72	0.81	0.95																																																			
0.8	3.47	3.55	3.69																																																			
1.6	6.35	6.39	6.52																																																			
2.4	9.33	9.34	9.44																																																			
3.2	12.34	12.31	12.35																																																			
4.0	15.55	15.44	15.41																																																			
4.4	17.22	17.03	16.97																																																			
--	-	-	-																																																			
--	-	-	-																																																			
--	-	-	-																																																			
--	-	-	-																																																			
<p>Note: Slanted line shows the range of the rated load current.</p>																																																						



<p>Model MGS15243R3</p>		<p>Temperature 25°C Testing Circuitry Figure A</p>																																
<p>Item</p>	<p>Efficiency (by Input Voltage)</p>																																	
<p>Object</p>	<p>_____</p>																																	
<p>1.Graph</p>		<p>2.Values</p>																																
<p>---□--- Load 50% —△— Load 100%</p> <p>Efficiency [%]</p> <p>Input Voltage [V]</p>		<table border="1"> <thead> <tr> <th rowspan="2">Input Voltage [V]</th> <th colspan="2">Efficiency [%]</th> </tr> <tr> <th>Load 50%</th> <th>Load 100%</th> </tr> </thead> <tbody> <tr><td>17</td><td>85.3</td><td>85.3</td></tr> <tr><td>18</td><td>85.4</td><td>85.4</td></tr> <tr><td>20</td><td>85.3</td><td>85.8</td></tr> <tr><td>24</td><td>85.1</td><td>86.3</td></tr> <tr><td>30</td><td>84.8</td><td>86.5</td></tr> <tr><td>36</td><td>84.3</td><td>86.4</td></tr> <tr><td>40</td><td>83.8</td><td>86.2</td></tr> <tr><td>--</td><td>-</td><td>-</td></tr> <tr><td>--</td><td>-</td><td>-</td></tr> </tbody> </table>	Input Voltage [V]	Efficiency [%]		Load 50%	Load 100%	17	85.3	85.3	18	85.4	85.4	20	85.3	85.8	24	85.1	86.3	30	84.8	86.5	36	84.3	86.4	40	83.8	86.2	--	-	-	--	-	-
Input Voltage [V]	Efficiency [%]																																	
	Load 50%	Load 100%																																
17	85.3	85.3																																
18	85.4	85.4																																
20	85.3	85.8																																
24	85.1	86.3																																
30	84.8	86.5																																
36	84.3	86.4																																
40	83.8	86.2																																
--	-	-																																
--	-	-																																
<p>Note: Slanted line shows the range of the rated input voltage.</p>																																		



Model		MGS15243R3		Temperature 25°C																																																				
Item		Efficiency (by Load Current)		Testing Circuitry Figure A																																																				
Object		_____																																																						
1.Graph			—△— Input Volt. 18V	2.Values																																																				
			- - □ - - Input Volt. 24V																																																					
			- · - ○ - · - Input Volt. 36V																																																					
<p>Note: Slanted line shows the range of the rated load current.</p>			<table border="1"> <thead> <tr> <th rowspan="2">Load Current [A]</th> <th colspan="3">Efficiency [%]</th> </tr> <tr> <th>Input Volt. 18[V]</th> <th>Input Volt. 24[V]</th> <th>Input Volt. 36[V]</th> </tr> </thead> <tbody> <tr><td>0.0</td><td>-</td><td>-</td><td>-</td></tr> <tr><td>0.8</td><td>77.1</td><td>75.4</td><td>72.5</td></tr> <tr><td>1.6</td><td>84.4</td><td>83.8</td><td>82.2</td></tr> <tr><td>2.4</td><td>86.2</td><td>86.1</td><td>85.2</td></tr> <tr><td>3.2</td><td>86.4</td><td>86.7</td><td>86.3</td></tr> <tr><td>4.0</td><td>85.6</td><td>86.4</td><td>86.6</td></tr> <tr><td>4.4</td><td>85.2</td><td>86.2</td><td>86.5</td></tr> <tr><td>--</td><td>-</td><td>-</td><td>-</td></tr> <tr><td>--</td><td>-</td><td>-</td><td>-</td></tr> <tr><td>--</td><td>-</td><td>-</td><td>-</td></tr> <tr><td>--</td><td>-</td><td>-</td><td>-</td></tr> </tbody> </table>			Load Current [A]	Efficiency [%]			Input Volt. 18[V]	Input Volt. 24[V]	Input Volt. 36[V]	0.0	-	-	-	0.8	77.1	75.4	72.5	1.6	84.4	83.8	82.2	2.4	86.2	86.1	85.2	3.2	86.4	86.7	86.3	4.0	85.6	86.4	86.6	4.4	85.2	86.2	86.5	--	-	-	-	--	-	-	-	--	-	-	-	--	-	-	-
Load Current [A]	Efficiency [%]																																																							
	Input Volt. 18[V]	Input Volt. 24[V]	Input Volt. 36[V]																																																					
0.0	-	-	-																																																					
0.8	77.1	75.4	72.5																																																					
1.6	84.4	83.8	82.2																																																					
2.4	86.2	86.1	85.2																																																					
3.2	86.4	86.7	86.3																																																					
4.0	85.6	86.4	86.6																																																					
4.4	85.2	86.2	86.5																																																					
--	-	-	-																																																					
--	-	-	-																																																					
--	-	-	-																																																					
--	-	-	-																																																					



<b>COSEL</b>																																			
Model	MGS15243R3	Temperature	25°C																																
Item	Line Regulation	Testing Circuitry	Figure A																																
Object	+3.3V4A																																		
<p>1.Graph</p> <div style="text-align: right;"> <p>---□--- Load 50%</p> <p>—△— Load 100%</p> </div> <p>Note: Slanted line shows the range of the rated input voltage.</p>		<p>2.Values</p> <table border="1"> <thead> <tr> <th rowspan="2">Input Voltage [V]</th> <th colspan="2">Output Voltage [V]</th> </tr> <tr> <th>Load 50%</th> <th>Load 100%</th> </tr> </thead> <tbody> <tr><td>17</td><td>3.343</td><td>3.341</td></tr> <tr><td>18</td><td>3.343</td><td>3.342</td></tr> <tr><td>20</td><td>3.343</td><td>3.342</td></tr> <tr><td>24</td><td>3.343</td><td>3.342</td></tr> <tr><td>30</td><td>3.343</td><td>3.342</td></tr> <tr><td>36</td><td>3.343</td><td>3.342</td></tr> <tr><td>40</td><td>3.343</td><td>3.342</td></tr> <tr><td>--</td><td>-</td><td>-</td></tr> <tr><td>--</td><td>-</td><td>-</td></tr> </tbody> </table>		Input Voltage [V]	Output Voltage [V]		Load 50%	Load 100%	17	3.343	3.341	18	3.343	3.342	20	3.343	3.342	24	3.343	3.342	30	3.343	3.342	36	3.343	3.342	40	3.343	3.342	--	-	-	--	-	-
Input Voltage [V]	Output Voltage [V]																																		
	Load 50%	Load 100%																																	
17	3.343	3.341																																	
18	3.343	3.342																																	
20	3.343	3.342																																	
24	3.343	3.342																																	
30	3.343	3.342																																	
36	3.343	3.342																																	
40	3.343	3.342																																	
--	-	-																																	
--	-	-																																	





<p>Model MGS15243R3</p> <p>Item Load Regulation</p> <p>Object +3.3V4A</p>		<p>Temperature 25°C</p> <p>Testing Circuitry Figure A</p>																																																			
<p>1.Graph</p> <p>—△— Input Volt. 18V</p> <p>---□--- Input Volt. 24V</p> <p>---○--- Input Volt. 36V</p> <p>Output Voltage [V]</p> <p>Load Current [A]</p> <p>Note: Slanted line shows the range of the rated load current.</p>		<p>2.Values</p> <table border="1"> <thead> <tr> <th rowspan="2">Load Current [A]</th> <th colspan="3">Output Voltage [V]</th> </tr> <tr> <th>Input Volt. 18[V]</th> <th>Input Volt. 24[V]</th> <th>Input Volt. 36[V]</th> </tr> </thead> <tbody> <tr><td>0.0</td><td>3.344</td><td>3.344</td><td>3.344</td></tr> <tr><td>0.8</td><td>3.344</td><td>3.344</td><td>3.343</td></tr> <tr><td>1.6</td><td>3.343</td><td>3.343</td><td>3.343</td></tr> <tr><td>2.4</td><td>3.343</td><td>3.343</td><td>3.343</td></tr> <tr><td>3.2</td><td>3.342</td><td>3.342</td><td>3.342</td></tr> <tr><td>4.0</td><td>3.342</td><td>3.342</td><td>3.342</td></tr> <tr><td>4.4</td><td>3.341</td><td>3.341</td><td>3.342</td></tr> <tr><td>--</td><td>-</td><td>-</td><td>-</td></tr> <tr><td>--</td><td>-</td><td>-</td><td>-</td></tr> <tr><td>--</td><td>-</td><td>-</td><td>-</td></tr> <tr><td>--</td><td>-</td><td>-</td><td>-</td></tr> </tbody> </table>	Load Current [A]	Output Voltage [V]			Input Volt. 18[V]	Input Volt. 24[V]	Input Volt. 36[V]	0.0	3.344	3.344	3.344	0.8	3.344	3.344	3.343	1.6	3.343	3.343	3.343	2.4	3.343	3.343	3.343	3.2	3.342	3.342	3.342	4.0	3.342	3.342	3.342	4.4	3.341	3.341	3.342	--	-	-	-	--	-	-	-	--	-	-	-	--	-	-	-
Load Current [A]	Output Voltage [V]																																																				
	Input Volt. 18[V]	Input Volt. 24[V]	Input Volt. 36[V]																																																		
0.0	3.344	3.344	3.344																																																		
0.8	3.344	3.344	3.343																																																		
1.6	3.343	3.343	3.343																																																		
2.4	3.343	3.343	3.343																																																		
3.2	3.342	3.342	3.342																																																		
4.0	3.342	3.342	3.342																																																		
4.4	3.341	3.341	3.342																																																		
--	-	-	-																																																		
--	-	-	-																																																		
--	-	-	-																																																		
--	-	-	-																																																		



Model	MGS15243R3	Temperature	25°C
Item	Dynamic Load Response	Testing Circuitry	Figure A
Object	+3.3V4A		

Input Volt. 24 V  
 Cycle 1000 ms

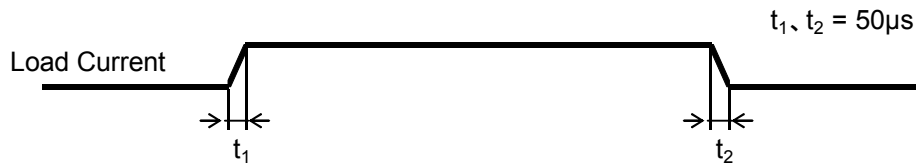

Min. Load (0A) ←→  
 Load 100% (4A)

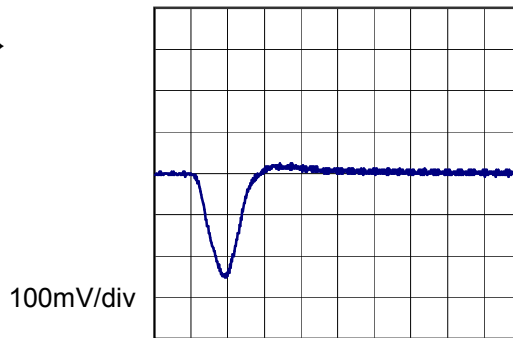

50µs/div

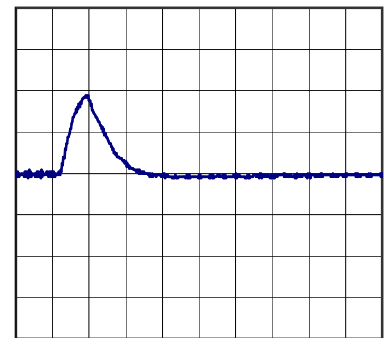

50µs/div

Min. Load (0A) ←→  
 Load 50% (2A)

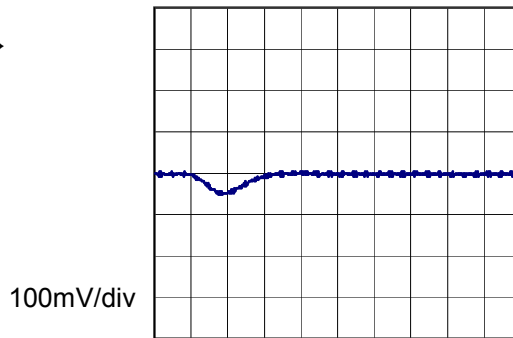

50µs/div

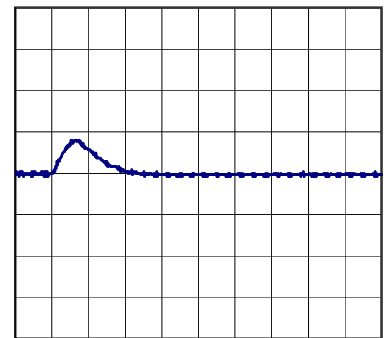

50µs/div

Load 50% (2A) ←→  
 Load 100% (4A)

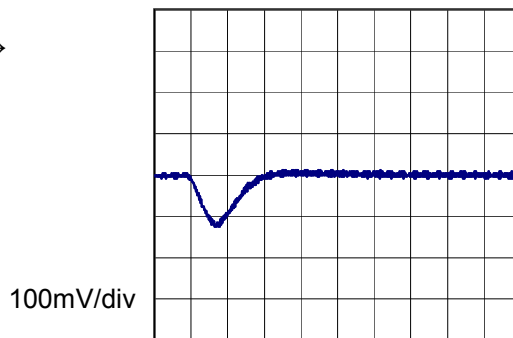

50µs/div

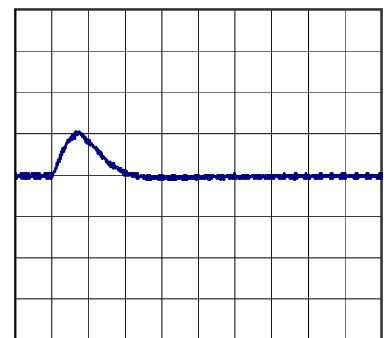

50µs/div

<p>Model MGS15243R3</p>		<p>Temperature 25°C Testing Circuitry Figure B</p>																																						
Item	Ripple Voltage (by Load Current)																																							
Object	+3.3V4A																																							
<p>1. Graph</p> <p>             —△— Input Volt. 18V              - - ○ - - Input Volt. 36V         </p>		<p>2. Values</p> <table border="1"> <thead> <tr> <th rowspan="2">Load Current [A]</th> <th colspan="2">Ripple Voltage [mV]</th> </tr> <tr> <th>Input Volt. 18 [V]</th> <th>Input Volt. 36 [V]</th> </tr> </thead> <tbody> <tr><td>0.0</td><td>5</td><td>6</td></tr> <tr><td>0.8</td><td>5</td><td>7</td></tr> <tr><td>1.6</td><td>5</td><td>7</td></tr> <tr><td>2.4</td><td>7</td><td>8</td></tr> <tr><td>3.2</td><td>8</td><td>9</td></tr> <tr><td>4.0</td><td>10</td><td>10</td></tr> <tr><td>4.4</td><td>11</td><td>10</td></tr> <tr><td>--</td><td>-</td><td>-</td></tr> <tr><td>--</td><td>-</td><td>-</td></tr> <tr><td>--</td><td>-</td><td>-</td></tr> <tr><td>--</td><td>-</td><td>-</td></tr> </tbody> </table>	Load Current [A]	Ripple Voltage [mV]		Input Volt. 18 [V]	Input Volt. 36 [V]	0.0	5	6	0.8	5	7	1.6	5	7	2.4	7	8	3.2	8	9	4.0	10	10	4.4	11	10	--	-	-	--	-	-	--	-	-	--	-	-
Load Current [A]	Ripple Voltage [mV]																																							
	Input Volt. 18 [V]	Input Volt. 36 [V]																																						
0.0	5	6																																						
0.8	5	7																																						
1.6	5	7																																						
2.4	7	8																																						
3.2	8	9																																						
4.0	10	10																																						
4.4	11	10																																						
--	-	-																																						
--	-	-																																						
--	-	-																																						
--	-	-																																						
<p>Measured by 100 MHz Oscilloscope. Ripple Voltage is shown as p-p in the figure below. Note: Slanted line shows the range of the rated load current.</p>																																								
<p>Ripple [mVp-p]</p> <p>Fig. Complex Ripple Wave Form</p>																																								

Model	MGS15243R3	Temperature	25°C
Item	Ripple-Noise	Testing Circuitry	Figure B
Object	+3.3V4A		

1. Graph

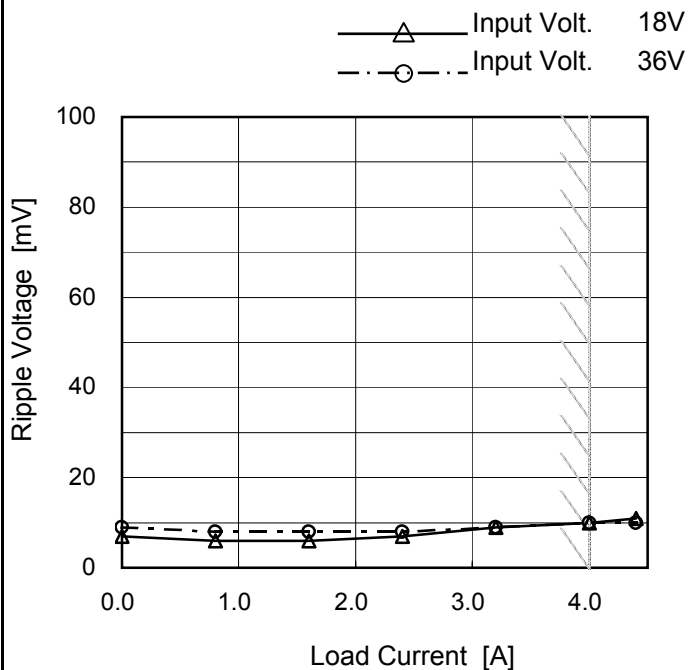

2. Values

Load Current [A]	Ripple-Noise [mV]	
	Input Volt. 18 [V]	Input Volt. 36 [V]
0.0	7	9
0.8	6	8
1.6	6	8
2.4	7	8
3.2	9	9
4.0	10	10
4.4	11	10
--	-	-
--	-	-
--	-	-
--	-	-

Measured by 100 MHz Oscilloscope.  
 Ripple-Noise is shown as p-p in the figure below.  
 Note: Slanted line shows the range of the rated load current.

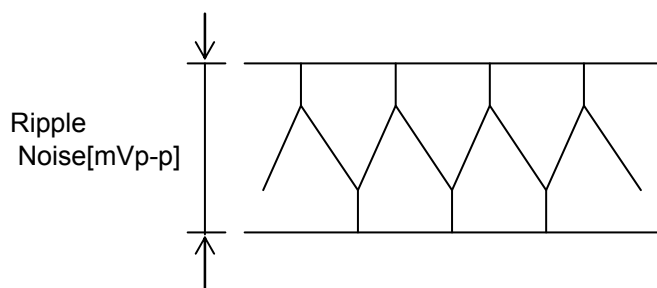
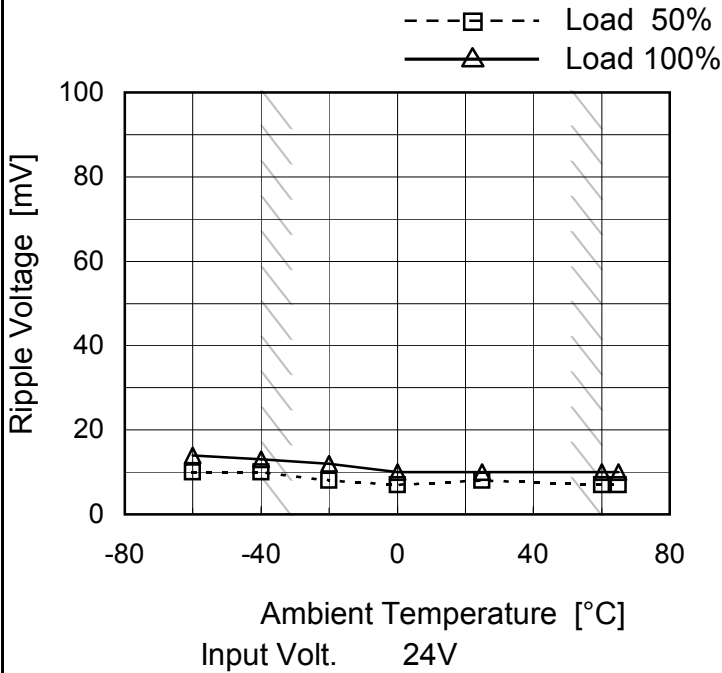

Fig.Complex Ripple Noise Wave Form

Model	MGS15243R3
Item	Ripple Voltage (by Ambient Temp.)
Object	+3.3V4A

Testing Circuitry Figure B

1. Graph



2. Values

Ambient Temperature [°C]	Ripple Voltage [mV]	
	Load 50%	Load 100%
-60	10	14
-40	10	13
-20	8	12
0	7	10
25	8	10
60	7	10
65	7	10
--	-	-
--	-	-
--	-	-
--	-	-

Measured by 100 MHz Oscilloscope.  
Note: Slanted line shows the range of the rated ambient temperature.



<b>COSEL</b>																																																					
Model	MGS15243R3																																																				
Item	Ambient Temperature Drift	Testing Circuitry Figure A																																																			
Object	+3.3V4A																																																				
1.Graph	<p>—△— Input Volt. 18V                  ---□--- Input Volt. 24V                  ···○··· Input Volt. 36V</p> <p style="text-align: center;">Ambient Temperature [°C] Load 100%</p>	2.Values																																																			
		<table border="1"> <thead> <tr> <th rowspan="2">Ambient Temperature [°C]</th> <th colspan="3">Output Voltage [V]</th> </tr> <tr> <th>Input Volt. 18[V]</th> <th>Input Volt. 24[V]</th> <th>Input Volt. 36[V]</th> </tr> </thead> <tbody> <tr><td>-60</td><td>3.346</td><td>3.346</td><td>3.346</td></tr> <tr><td>-40</td><td>3.347</td><td>3.347</td><td>3.347</td></tr> <tr><td>-20</td><td>3.345</td><td>3.346</td><td>3.346</td></tr> <tr><td>0</td><td>3.343</td><td>3.343</td><td>3.343</td></tr> <tr><td>25</td><td>3.342</td><td>3.342</td><td>3.342</td></tr> <tr><td>60</td><td>3.339</td><td>3.339</td><td>3.339</td></tr> <tr><td>65</td><td>3.338</td><td>3.338</td><td>3.338</td></tr> <tr><td>--</td><td>-</td><td>-</td><td>-</td></tr> <tr><td>--</td><td>-</td><td>-</td><td>-</td></tr> <tr><td>--</td><td>-</td><td>-</td><td>-</td></tr> <tr><td>--</td><td>-</td><td>-</td><td>-</td></tr> </tbody> </table>	Ambient Temperature [°C]	Output Voltage [V]			Input Volt. 18[V]	Input Volt. 24[V]	Input Volt. 36[V]	-60	3.346	3.346	3.346	-40	3.347	3.347	3.347	-20	3.345	3.346	3.346	0	3.343	3.343	3.343	25	3.342	3.342	3.342	60	3.339	3.339	3.339	65	3.338	3.338	3.338	--	-	-	-	--	-	-	-	--	-	-	-	--	-	-	-
Ambient Temperature [°C]	Output Voltage [V]																																																				
	Input Volt. 18[V]	Input Volt. 24[V]	Input Volt. 36[V]																																																		
-60	3.346	3.346	3.346																																																		
-40	3.347	3.347	3.347																																																		
-20	3.345	3.346	3.346																																																		
0	3.343	3.343	3.343																																																		
25	3.342	3.342	3.342																																																		
60	3.339	3.339	3.339																																																		
65	3.338	3.338	3.338																																																		
--	-	-	-																																																		
--	-	-	-																																																		
--	-	-	-																																																		
--	-	-	-																																																		
<p>Note: Slanted line shows the range of the rated ambient temperature.</p>																																																					



<b>COSEL</b>		
Model	MGS15243R3	
Item	Output Voltage Accuracy	Testing Circuitry Figure A
Object	+3.3V4A	

1. Output Voltage Accuracy

This is defined as the value of the output voltage, regulation load, ambient temperature and input voltage varied at random in the range as specified below.

Temperature : -40 - 60°C

Input Voltage : 18 - 36V

Load Current : 0 - 4A

\* Output Voltage Accuracy =  $\pm(\text{Maximum of Output Voltage} - \text{Minimum of Output Voltage}) / 2$

\* Output Voltage Accuracy (Ration) =  $\frac{\text{Output Voltage Accuracy}}{\text{Rated Output Voltage}} \times 100$

2. Values

Item	Temperature [°C]	Input Voltage[V]	Output		Output Voltage Accuracy	
			Current[A]	Voltage[V]	Value [mV]	Ration [%]
Maximum Voltage	-40	18	0	3.350	±6	±0.2
Minimum Voltage	60	18	4	3.339		



<b>COSEL</b>																								
Model	MGS15243R3																							
Item	Time Lapse Drift	Temperature 25°C Testing Circuitry Figure A																						
Object	+3.3V4A																							
<p>1.Graph</p> <p style="text-align: center;">Time [H]</p> <p>Input Volt. 24V Load 100%</p>		<p>2.Values</p> <table border="1"> <thead> <tr> <th>Time since start [H]</th> <th>Output Voltage [V]</th> </tr> </thead> <tbody> <tr><td>0.0</td><td>3.342</td></tr> <tr><td>0.5</td><td>3.341</td></tr> <tr><td>1.0</td><td>3.341</td></tr> <tr><td>2.0</td><td>3.341</td></tr> <tr><td>3.0</td><td>3.341</td></tr> <tr><td>4.0</td><td>3.341</td></tr> <tr><td>5.0</td><td>3.341</td></tr> <tr><td>6.0</td><td>3.341</td></tr> <tr><td>7.0</td><td>3.341</td></tr> <tr><td>8.0</td><td>3.341</td></tr> </tbody> </table>	Time since start [H]	Output Voltage [V]	0.0	3.342	0.5	3.341	1.0	3.341	2.0	3.341	3.0	3.341	4.0	3.341	5.0	3.341	6.0	3.341	7.0	3.341	8.0	3.341
Time since start [H]	Output Voltage [V]																							
0.0	3.342																							
0.5	3.341																							
1.0	3.341																							
2.0	3.341																							
3.0	3.341																							
4.0	3.341																							
5.0	3.341																							
6.0	3.341																							
7.0	3.341																							
8.0	3.341																							





Model		MGS15243R3	Temperature	25°C
Item		Rise and Fall Time	Testing Circuitry	Figure A
Object		+3.3V4A		

1. Graph

Input Volt. 24 V

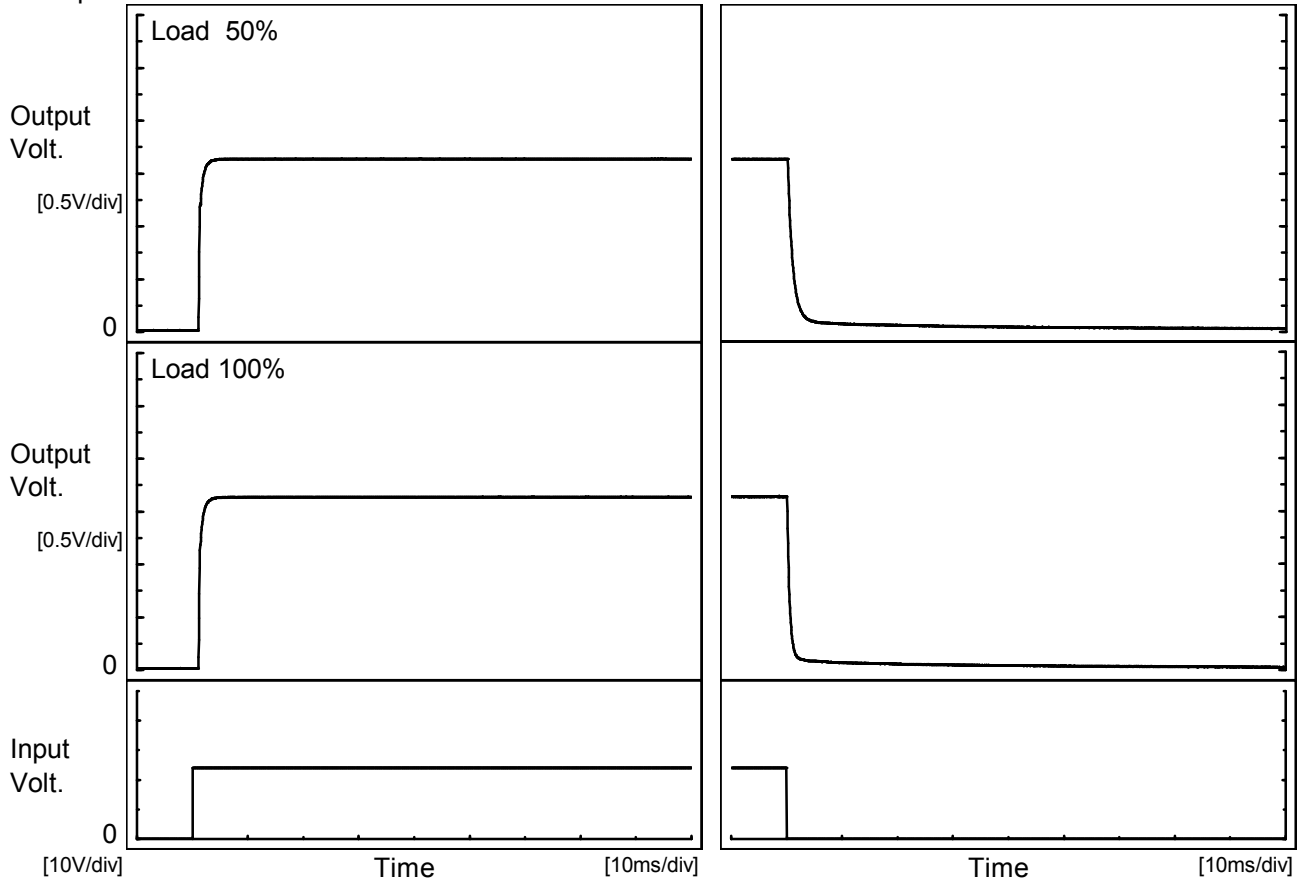

2. Values

		[ms]				
Load \ Time	Time	Td	Tr	Ts	Th	Tf
50 %		1.2	1.0	2.2	0.2	2.5
100 %		1.2	1.0	2.2	0.2	1.2

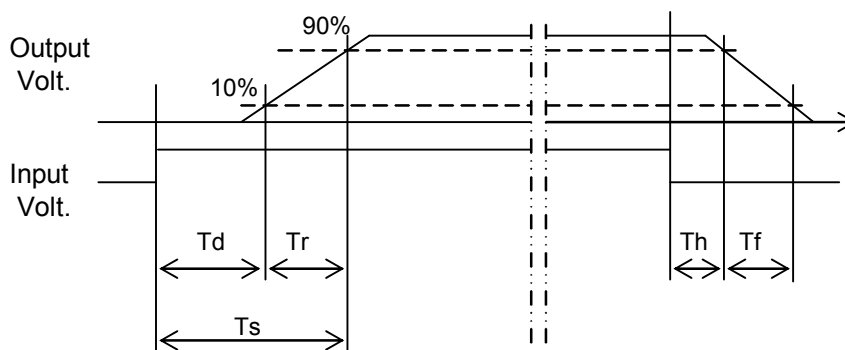



<b>COSEL</b>																																								
Model	MGS15243R3																																							
Item	Minimum Input Voltage for Regulated Output Voltage	Testing Circuitry Figure A																																						
Object	+3.3V4A																																							
<p>1.Graph</p> <p style="text-align: right;">             ---□--- Load 50%              —△— Load 100%         </p>		<p>2.Values</p> <table border="1"> <thead> <tr> <th rowspan="2">Ambient Temperature [°C]</th> <th colspan="2">Input Voltage [V]</th> </tr> <tr> <th>Load 50%</th> <th>Load 100%</th> </tr> </thead> <tbody> <tr><td>-60</td><td>16.0</td><td>15.9</td></tr> <tr><td>-40</td><td>15.9</td><td>15.9</td></tr> <tr><td>-20</td><td>15.9</td><td>16.0</td></tr> <tr><td>0</td><td>15.9</td><td>15.9</td></tr> <tr><td>25</td><td>15.9</td><td>15.8</td></tr> <tr><td>60</td><td>15.8</td><td>15.8</td></tr> <tr><td>65</td><td>15.8</td><td>15.8</td></tr> <tr><td>--</td><td>-</td><td>-</td></tr> <tr><td>--</td><td>-</td><td>-</td></tr> <tr><td>--</td><td>-</td><td>-</td></tr> <tr><td>--</td><td>-</td><td>-</td></tr> </tbody> </table>	Ambient Temperature [°C]	Input Voltage [V]		Load 50%	Load 100%	-60	16.0	15.9	-40	15.9	15.9	-20	15.9	16.0	0	15.9	15.9	25	15.9	15.8	60	15.8	15.8	65	15.8	15.8	--	-	-	--	-	-	--	-	-	--	-	-
Ambient Temperature [°C]	Input Voltage [V]																																							
	Load 50%	Load 100%																																						
-60	16.0	15.9																																						
-40	15.9	15.9																																						
-20	15.9	16.0																																						
0	15.9	15.9																																						
25	15.9	15.8																																						
60	15.8	15.8																																						
65	15.8	15.8																																						
--	-	-																																						
--	-	-																																						
--	-	-																																						
--	-	-																																						
<p>Note: Slanted line shows the range of the rated ambient temperature.</p>																																								



<p>Model MGS15243R3</p> <p>Item Overcurrent Protection</p> <p>Object +3.3V4A</p>		<p>Temperature 25°C</p> <p>Testing Circuitry Figure A</p>																																																							
<p>1.Graph</p> <p>                     —△ Input Volt. 18V                      —□ Input Volt. 24V                      —○ Input Volt. 36V                 </p> <p>                     Note: Slanted line shows the range of the rated load current.                      Intermittent operation occurs when overcurrent protection is activated.                 </p>		<p>2.Values</p> <table border="1"> <thead> <tr> <th rowspan="2">Output Voltage [V]</th> <th colspan="3">Load Current [A]</th> </tr> <tr> <th>Input Volt. 18[V]</th> <th>Input Volt. 24[V]</th> <th>Input Volt. 36[V]</th> </tr> </thead> <tbody> <tr><td>3.30</td><td>5.64</td><td>5.99</td><td>5.75</td></tr> <tr><td>3.14</td><td>-</td><td>-</td><td>-</td></tr> <tr><td>2.97</td><td>-</td><td>-</td><td>-</td></tr> <tr><td>2.64</td><td>-</td><td>-</td><td>-</td></tr> <tr><td>2.31</td><td>-</td><td>-</td><td>-</td></tr> <tr><td>1.98</td><td>-</td><td>-</td><td>-</td></tr> <tr><td>1.65</td><td>-</td><td>-</td><td>-</td></tr> <tr><td>1.32</td><td>-</td><td>-</td><td>-</td></tr> <tr><td>0.99</td><td>-</td><td>-</td><td>-</td></tr> <tr><td>0.66</td><td>-</td><td>-</td><td>-</td></tr> <tr><td>0.33</td><td>-</td><td>-</td><td>-</td></tr> <tr><td>0.00</td><td>-</td><td>-</td><td>-</td></tr> </tbody> </table>	Output Voltage [V]	Load Current [A]			Input Volt. 18[V]	Input Volt. 24[V]	Input Volt. 36[V]	3.30	5.64	5.99	5.75	3.14	-	-	-	2.97	-	-	-	2.64	-	-	-	2.31	-	-	-	1.98	-	-	-	1.65	-	-	-	1.32	-	-	-	0.99	-	-	-	0.66	-	-	-	0.33	-	-	-	0.00	-	-	-
Output Voltage [V]	Load Current [A]																																																								
	Input Volt. 18[V]	Input Volt. 24[V]	Input Volt. 36[V]																																																						
3.30	5.64	5.99	5.75																																																						
3.14	-	-	-																																																						
2.97	-	-	-																																																						
2.64	-	-	-																																																						
2.31	-	-	-																																																						
1.98	-	-	-																																																						
1.65	-	-	-																																																						
1.32	-	-	-																																																						
0.99	-	-	-																																																						
0.66	-	-	-																																																						
0.33	-	-	-																																																						
0.00	-	-	-																																																						

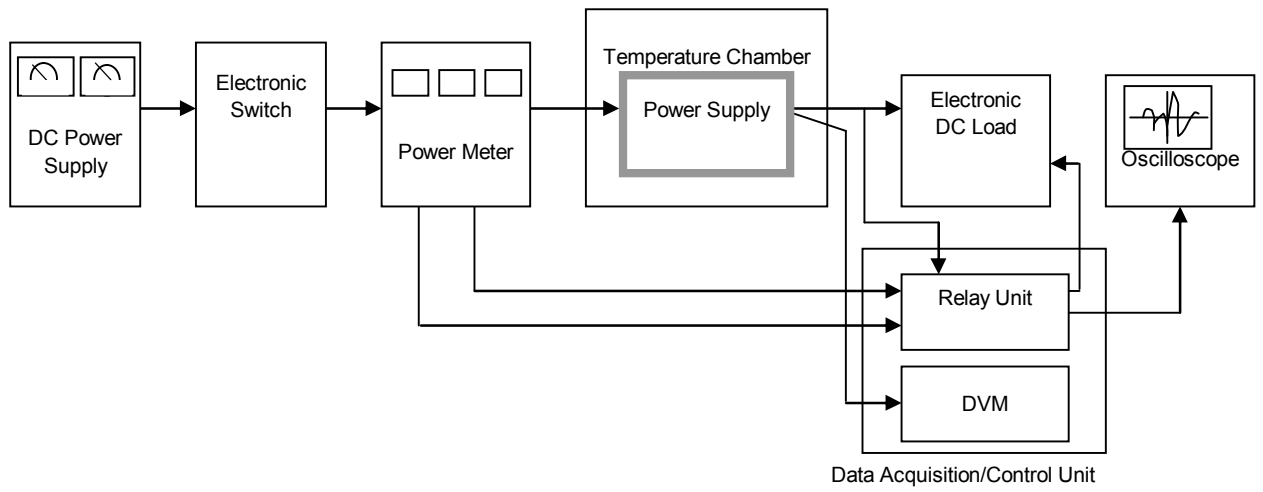

Figure A

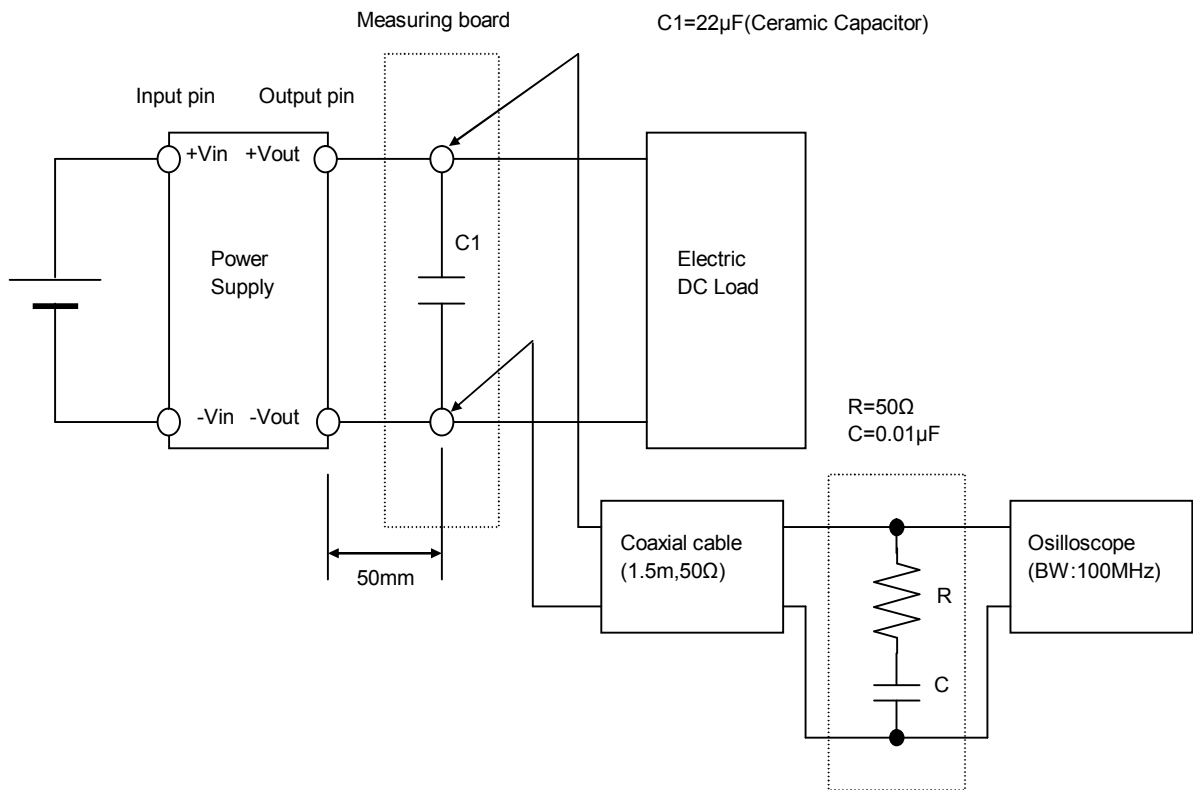

Figure B (Ripple and Ripple noise Characteristic)