



MGS10 series Reliability test results

Jul 29, 2016  
OS DESIGN DEPT.

Approved : Takayuki Fukuda  
Takayuki Fukuda

Prepared : Ryosuke Nakao  
Ryosuke Nakao

No.	Test Item	Testing conditions	Conditions of acceptability	Number of samples	Number of failures
1	Heat cycle test	(1) -40° C ~ 125° C 30minutes each (2) 800cycles	(1)No degradation of electric characteristics after test. (2)No crack at solder joint.	5	0
2	High temperature/ High humidity bias test	(1) Ta=85°C, RH=85% (2) Input Max.Voltege (3) Load 0% (4) 1000hours	(1)No degradation of electric characteristics after test.	5	0
3	Vibration test	(1) f=10~55Hz, 98.0m/s <sup>2</sup> (10G) (2) 3minutes period (3) 60minutes each X, Y and Z axis	(1)No degradation of electric characteristics after test. (2)No crack at solder joint. (3)No mechanical damage of appearance.	6	0
4	Impact test	(1) 490.3m/s <sup>2</sup> (50G), 11ms (2) Once each X, Y and Z axis	(1)No degradation of electric characteristics after test. (2)No crack at solder joint. (3)No thermal damage of appearance.	3	0
5	Soldering heat test	(1) Soldering iron 340~360°C, 7.5 seconds (2) Mounting board : t=1.6mm / FR4	(1)No crack at solder joint. (2)No marked damage of appearance.	1	0
6	Pin solder ability test	(1) Pre-process Step1 Humidifying processing (100°C, 100%, 1H) Step2 Dip into flux (2) Dip soldering 230~240°C, 2sec	(1)Over 95% of dipped part is covered with solder.	3	0
7	Pin strength test	(1) Weight : 1kg (2) Bending angle : 90 deg., total 180 deg. (3) 1 cycle	(1)No crack at solder joint. (2)No mechanical damage of appearance.	1	0
8	Static electricity immunity test	(1) Applied voltage ±4kV (2) At rated input and load (3) Testing circuitry Fig.1	(1)No protection circuit fail. (2)No output voltage drop due to control (3)No any other function fail.	1	0



○Testing circuitry

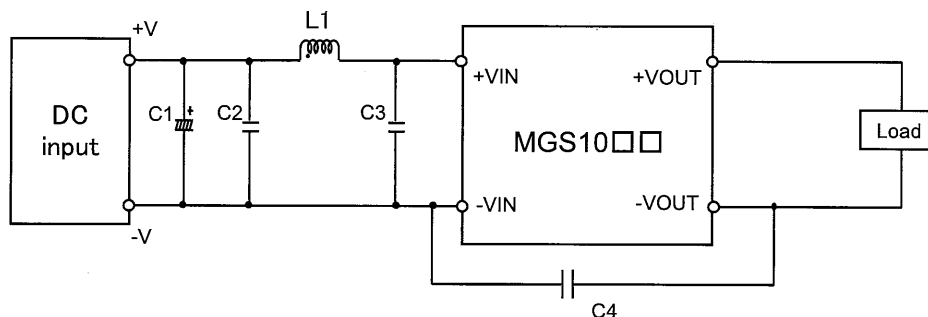

Fig.1 Testing circuitry

C1 :	MGS1005□□	25V 470 $\mu$ F Electric capacitor (LXZseries NIPPON CHEMI-CON)
	MGS1012□□	50V 100 $\mu$ F Electric capacitor (LXZseries NIPPON CHEMI-CON)
	MGS1024□□	50V 100 $\mu$ F Electric capacitor (LXZseries NIPPON CHEMI-CON)
	MGS1048□□	100V 39 $\mu$ F Electric capacitor (LXVseries NIPPON CHEMI-CON)
C2 :	MGS1005□□	16V 22 $\mu$ F Ceramic capacitor (GRM31CC71C226K MURATA MANUFACTURING)
	MGS1012□□	25V 10 $\mu$ F Ceramic capacitor (GRM31CR71E106K MURATA MANUFACTURING)
	MGS1024□□	50V 4.7 $\mu$ F Ceramic capacitor (GRM31CR71H475K MURATA MANUFACTURING)
	MGS1048□□	100V 2.2 $\mu$ F Ceramic capacitor (GRM31CC72A225K MURATA MANUFACTURING)
C3 :	MGS1005□□	-
	MGS1012□□	25V 10 $\mu$ F Ceramic capacitor (GRM31CR71E106K MURATA MANUFACTURING)
	MGS1024□□	50V 4.7 $\mu$ F Ceramic capacitor (GRM31CR71H475K MURATA MANUFACTURING)
	MGS1048□□	100V 2.2 $\mu$ F Ceramic capacitor (GRM31CC72A225K MURATA MANUFACTURING)
C4 :	MGS1005□□	2kV 1000pF Ceramic capacitor (GR442QR73D102K MURATA MANUFACTURING)
	MGS1012□□	2kV 1000pF Ceramic capacitor (GR442QR73D102K MURATA MANUFACTURING)
	MGS1024□□	2kV 1000pF Ceramic capacitor (GR442QR73D102K MURATA MANUFACTURING)
	MGS1048□□	2kV 2200pF Ceramic capacitor (GR443QR73D222K MURATA MANUFACTURING)
L1 :	MGS1005□□	3000mA 1.5 $\mu$ H Inductor(LQH5BPN1R5NT0 MURATA MANUFACTURING)
	MGS1012□□	2600mA 2.2 $\mu$ H Inductor(LQH5BPN2R2NT0 MURATA MANUFACTURING)
	MGS1024□□	1600mA 10 $\mu$ H Inductor(LQH5BPN100MT0 MURATA MANUFACTURING)
	MGS1048□□	1050mA 22 $\mu$ H Inductor(LQH5BPN220MT0 MURATA MANUFACTURING)