



MGFS6 Series EMI/EMS Test results

Approved : *Takayuki Fukuda*
Takayuki Fukuda

Prepared : *Takaaki Sekiguchi*
Takaaki Sekiguchi

No.	Test item	Conditions	Conditions of Acceptability	Result
1	Line conduction	(1) Rated input (2) Rated load (3) Ambient temp. $25 \pm 10^{\circ}\text{C}$ (4) Testing circuitry Fig.1	(1)Meets the undermentioned standard. FCC Part15 classA , VCCI classA CISPR22 classA , EN55022-A	ok
2	Radiated emission	(1) Rated input (2) Rated load (3) Ambient temp. $25 \pm 10^{\circ}\text{C}$ (4) Testing circuitry Fig.1	(1)Meets the under mentioned standard. FCC Part15 classA , VCCI classA CISPR22 classA , EN55022-A	ok
3	Static electricity immunity test (EN61000-4-2)	(1) Rated input (2) Rated load (3) Ambient temp. $25 \pm 10^{\circ}\text{C}$ (4) Contact discharge voltage 4[kV] (EN61000-4-2 Level 2) (5) Testing circuitry Fig.1	(1)No protection circuit failure. (2)No output voltage drop with control circuit failure. (3)No any other function failure.	ok
4	Radiated, radio-frequency, electromagnetic field immunity test (EN61000-4-3)	(1) Rated input (2) Rated load (3) Ambient temp. $25 \pm 10^{\circ}\text{C}$ (4)Testing field strength (Level 3) ① 10 [V/m] (80MHz to 1.0GHz) ② 3 [V/m] (1.4GHz to 2.0GHz) ③ 1 [V/m] (2.0GHz to 2.7GHz) (5) Testing circuitry Fig.1	(1)No protection circuit failure. (2)No output voltage drop with control circuit failure. (3)No any other function failure.	ok
5	Electrical fast transient/ burst immunity test (EN61000-4-4)	(1) Rated input (2) Rated load (3) Ambient temp. $25 \pm 10^{\circ}\text{C}$ (4) Test peak voltage 4[kV] (IEC61000-4-4 Level 4) (5) Testing circuitry Fig.1	(1)No protection circuit failure. (2)No output voltage drop with control circuit failure. (3)No any other function failure.	ok
6	Surge immunity test (EN61000-4-5)	(1) Rated input (2) Rated load (3) Ambient temp. $25 \pm 10^{\circ}\text{C}$ (4) Test voltage Line to line 2[kV] (Level 3) (5) Testing circuitry Fig.2	(1)The power supply is not stop. (2)Circuit does not malfunction. (3)No abnormality of the insulation destruction etc. (4)Parts are no damaged.	ok

Conditions

Test : Line conduction , Radiated emission
 Static electricity immunity test
 Radiated, radio-frequency, electromagnetic field immunity test
 Electrical fast transient / burst immunity test

Model Name : MGFS6□□

○Testing circuitry

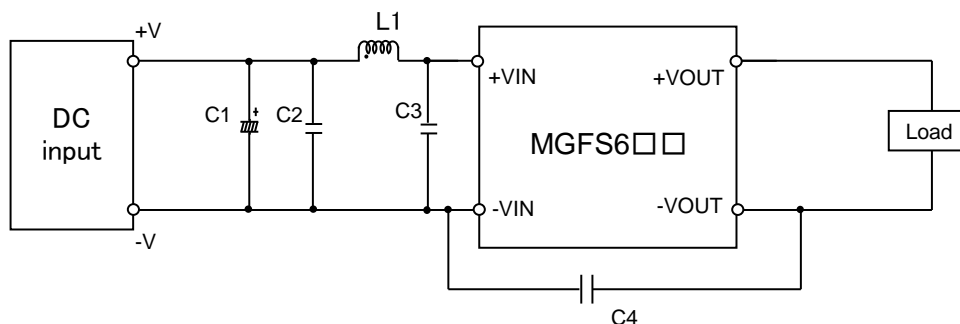

Fig.1 Testing circuitry

- | | | |
|------|-----------|--|
| C1 : | MGFS624□□ | 50V 100 μ F Electric capacitor (LXZseries NIPPON CHEMI-CON) |
| | MGFS648□□ | - |
| C2 : | MGFS624□□ | 50V 4.7 μ F Ceramic capacitor (GRM31CR71H475K MURATA MANUFACTURING) |
| | MGFS648□□ | 100V 2.2 μ F Ceramic capacitor (GRM31CC72A225K MURATA MANUFACTURING) |
| C3 : | MGFS624□□ | 50V 4.7 μ F Ceramic capacitor (GRM31CR71H475K MURATA MANUFACTURING) |
| | MGFS648□□ | 100V 2.2 μ F Ceramic capacitor (GRM31CC72A225K MURATA MANUFACTURING) |
| C4 : | MGFS624□□ | 2kV 470pF Ceramic capacitor (GR442QR73D471K MURATA MANUFACTURING) |
| | MGFS648□□ | 2kV 2200pF Ceramic capacitor (GR443QR73D222K MURATA MANUFACTURING) |
| L1 : | MGFS624□□ | 1600mA 10 μ H Inductor(LQH5BPN100MT0 MURATA MANUFACTURING) |
| | MGFS648□□ | 1050mA 22 μ H Inductor(LQH5BPN220MT0 MURATA MANUFACTURING) |

Conditions

Test : Surge immunity test

Model Name : MGFS6□□

○Testing circuitry

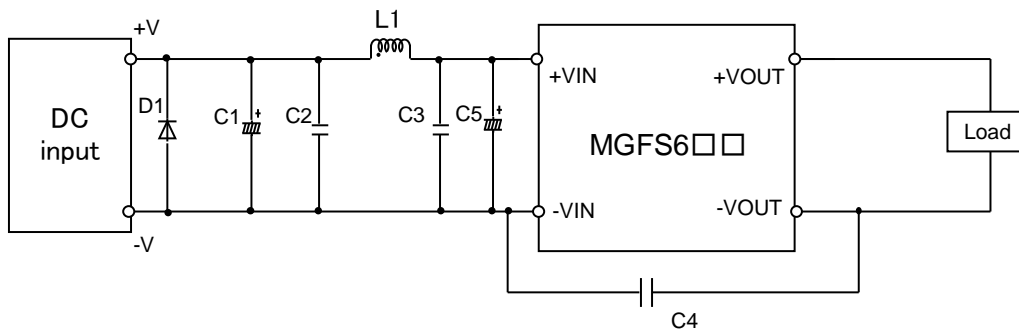

Fig.2 Testing circuitry

- | | | |
|------|-----------|--|
| C1 : | MGFS624□□ | 63V 470 μ F Electric capacitor (LXZseries NIPPON CHEMI-CON) |
| | MGFS648□□ | 100V 180 μ F Electric capacitor (LXVseries NIPPON CHEMI-CON) |
| C2 : | MGFS624□□ | 50V 4.7 μ F Ceramic capacitor (GRM31CR71H475K MURATA MANUFACTURING) |
| | MGFS648□□ | 100V 2.2 μ F Ceramic capacitor (GRM31CC72A225K MURATA MANUFACTURING) |
| C3 : | MGFS624□□ | 50V 4.7 μ F Ceramic capacitor (GRM31CR71H475K MURATA MANUFACTURING) |
| | MGFS648□□ | 100V 2.2 μ F Ceramic capacitor (GRM31CC72A225K MURATA MANUFACTURING) |
| C4 : | MGFS624□□ | 2kV 470pF Ceramic capacitor (GR442QR73D471K MURATA MANUFACTURING) |
| | MGFS648□□ | 2kV 2200pF Ceramic capacitor (GR443QR73D222K MURATA MANUFACTURING) |
| C5 : | MGFS624□□ | 63V 470 μ F Electric capacitor (LXZseries NIPPON CHEMI-CON) |
| | MGFS648□□ | 100V 180 μ F Electric capacitor (LXVseries NIPPON CHEMI-CON) |
| L1 : | MGFS624□□ | 1600mA 10 μ H Inductor(LQH5BPN100MT0 MURATA MANUFACTURING) |
| | MGFS648□□ | 1050mA 22 μ H Inductor(LQH5BPN220MT0 MURATA MANUFACTURING) |
| D1 : | MGFS624□□ | 400V 3A Diode(S3L40U SHINDENGEN) |
| | MGFS648□□ | 400V 3A Diode(S3L40U SHINDENGEN) |