

Approved : Yukihiro Takehashi  
Yukihiro Takehashi

Prepared : Yasunari Hirano  
Yasunari Hirano

No.	Test item	Test Conditions	Conditions of acceptability	Result
1	High temp./Overload test	(1) Rated input DC24V (2) Overload (3) Ambient temp. 60°C (4) Test period 48 hours	(1)Module is not failed.	OK
2	No ventilation test	(1) Rated input DC24V (2) Rated output (3) Ambient temp. 25±10°C (4) Test period 48 hours	(1)No smoke, no fire.	OK
3	Capacitance reduction test	(1) Rated input DC24V (2) Rated output (3) Ambient temp. 25±10°C	(1)No smoke, no fire. (2)No rise of the output voltage.	OK
4	Withstand voltage test (High-pot test)	(1) Input : Not applied (2) Ambient temp. 25±10°C (3) The applied voltage is 1.4 times of specifications.	(1)Insulation breakdown , flashover or electric arc is not occurred.	OK
5	Isolation resistance test	(1) Input : Not applied (2) Ambient temp. 25±10°C	(1)When a regulation voltage is applied, isolation resistance is 1.4 times of specifications.	OK
6	Vibration/Impact test	Vibration: (1)f =10~150Hz : 23.5m/s <sup>2</sup> (2)3 minutes period (3)60 minutes Z axis  Impact: (1)294.2m/s <sup>2</sup> 11ms (2)Once each X, Y and Z axis	(1)No degradation of electric characteristics after test. (2)No crack at solder joint. (3)No marked damage of appearance.	OK
7	Line noise tolerance test	(1) Input DC24V (2) Rated Output (3) Ambient temp 25±10°C (4) Test Voltage ±3 kV (5) Pulse width 50~1000ns (6) Mode : Normal and Common	(1)No protection circuit failure. (2)No output voltage drop with control circuit failure. (3)No any other function failure.	OK

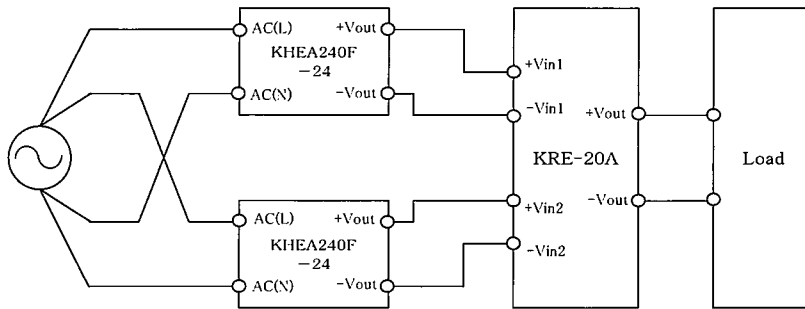

Fig.1 Testing circuitry (KRE-20A)

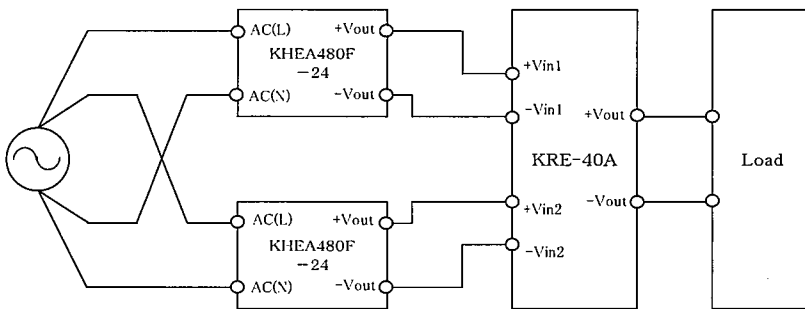

Fig.2 Testing circuitry (KRE-40A)