

Temperature increase of main components 主要部品温度上昇

Model: DBS700B

1. Conditions

- (1) Input : DC 200~400 [V]
- (2) Output : Rated output
- (3) Aluminum base plate temp. : 85 [°C] (Fig1.1)
- (4) Ambient temp. : 25 [°C]

2. Result

The temperature Increase based on the aluminum base plate is shown below.

No.	Parts name	Symbol No.	Increase (ΔT)			Rated temp. [°C]	Reference
			[deg]				
			12	24	28		
1	Switching transistor	TR11	21	20	18	150	Junction temp.
2	Switching transistor	TR13	16	15	14	150	Junction temp.
3	Rectified diode(Output)	SS51	35	32	30	150	Junction temp.
4	Rectified diode(Output)	SS53	37	39	33	150	Junction temp.
5	Transformer(coil)	T11	25	20	20	155	
6	Output choke(coil)	L51	29	28	34	155	
7							
8							
9							
10							
11							
12							
13							
14							
15							
16							
17							
18							
19							
20							

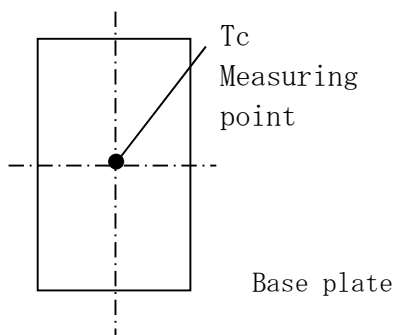

Fig.1.1 Measuring point of aluminum base plate temperature.

Temperature increase of main components 主要部品温度上昇

Model: DBS700B

1. Conditions

- (1) Input : DC 200~400 [V]
- (2) Output : Rated output
- (3) Aluminum base plate temp. : 70 [°C] (Fig1.1)
- (4) Ambient temp. : 25 [°C]

2. Result

The temperature Increase based on the aluminum base plate is shown below.

No.	Parts name	Symbol No.	Increase (ΔT)				Rated temp. [°C]	Reference
			[deg]					
			36	48				
1	Switching transistor	TR11	18	15		150	Junction temp.	
2	Switching transistor	TR13	15	12		150	Junction temp.	
3	Rectified diode(Output)	SS51	29	23		150	Junction temp.	
4	Rectified diode(Output)	SS53	29	22		150	Junction temp.	
5	Transformer(coil)	T11	48	28		155		
6	Output choke(coil)	L51	34	27		155		
7								
8								
9								
10								
11								
12								
13								
14								
15								
16								
17								
18								
19								
20								

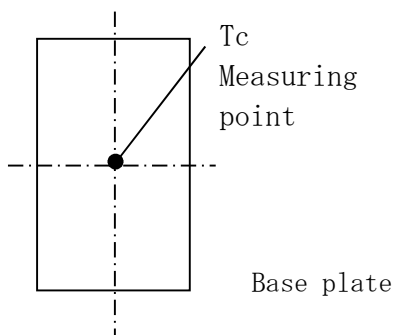

Fig.1.1 Measuring point of aluminum base plate temperature.