

TEST DATA OF AME400F

(200VAC INPUT)

Regulated DC power supply
August 21, 2019

Approved by : *Yoshimichi Hirokawa*
Yoshimichi Hirokawa Design Manager

Prepared by : *Takashi Yamamine*
Takashi Yamamine Design Engineer

INPUT : 170 - 264VAC

COSEL CO.,LTD.

CONTENTS

1. Input Current ·····	1
2. Input Power ·····	2
3. Efficiency (by Input Voltage) ·····	3
4. Efficiency (by Load Power) ·····	4
5. Power Factor (by Input Voltage) ·····	5
6. Power Factor (by Load Power) ·····	6
7. Inrush Current ·····	7
8. Leakage Current ·····	8
9. Rise and Fall Time ·····	9
10. Hold-up Time ·····	10
11. Instantaneous Interruption Compensation ·····	11
12. Minimum Input Voltage for Regulated Output Voltage ·····	12
13. Figure of Testing Circuitry ·····	13

(Final Page 14)



Model		AME400F		Temperature 25°C																																																				
Item		Input Current		Testing Circuitry Figure A																																																				
Object		_____																																																						
1. Graph		—△— Input Volt. 170 V - - - □ - - - Input Volt. 200 V - · - ○ - · - - Input Volt. 230 V		2. Value																																																				
				<table border="1"> <thead> <tr> <th rowspan="2">Load Power [W]</th> <th colspan="3">Input Current [A]</th> </tr> <tr> <th>Input Volt. 170[V]</th> <th>Input Volt. 200[V]</th> <th>Input Volt. 230[V]</th> </tr> </thead> <tbody> <tr><td>0</td><td>0.197</td><td>0.187</td><td>0.189</td></tr> <tr><td>80</td><td>0.723</td><td>0.631</td><td>0.564</td></tr> <tr><td>160</td><td>1.226</td><td>1.055</td><td>0.934</td></tr> <tr><td>240</td><td>1.742</td><td>1.491</td><td>1.306</td></tr> <tr><td>320</td><td>2.243</td><td>1.917</td><td>1.675</td></tr> <tr><td>400</td><td>2.756</td><td>2.347</td><td>2.042</td></tr> <tr><td>440</td><td>3.013</td><td>2.562</td><td>2.231</td></tr> <tr><td>--</td><td>--</td><td>--</td><td>--</td></tr> <tr><td>--</td><td>--</td><td>--</td><td>--</td></tr> <tr><td>--</td><td>--</td><td>--</td><td>--</td></tr> <tr><td>--</td><td>--</td><td>--</td><td>--</td></tr> </tbody> </table>		Load Power [W]	Input Current [A]			Input Volt. 170[V]	Input Volt. 200[V]	Input Volt. 230[V]	0	0.197	0.187	0.189	80	0.723	0.631	0.564	160	1.226	1.055	0.934	240	1.742	1.491	1.306	320	2.243	1.917	1.675	400	2.756	2.347	2.042	440	3.013	2.562	2.231	--	--	--	--	--	--	--	--	--	--	--	--	--	--	--	--
Load Power [W]	Input Current [A]																																																							
	Input Volt. 170[V]	Input Volt. 200[V]	Input Volt. 230[V]																																																					
0	0.197	0.187	0.189																																																					
80	0.723	0.631	0.564																																																					
160	1.226	1.055	0.934																																																					
240	1.742	1.491	1.306																																																					
320	2.243	1.917	1.675																																																					
400	2.756	2.347	2.042																																																					
440	3.013	2.562	2.231																																																					
--	--	--	--																																																					
--	--	--	--																																																					
--	--	--	--																																																					
--	--	--	--																																																					
Note: Hatched line shows the range of the rated load power.																																																								



<p>Model AME400F</p>		<p>Temperature 25°C Testing Circuitry Figure A</p>																																																			
Item	Input Power																																																				
Object	_____																																																				
<p>1. Graph</p> <p> —△— Input Volt. 170 V - - - □ - - - Input Volt. 200 V - · - ○ - · - - Input Volt. 230 V </p> <p>Input Power [W]</p> <p>Load Power [W]</p>		<p>2. Value</p> <table border="1"> <thead> <tr> <th rowspan="2">Load Power [W]</th> <th colspan="3">Input Power [W]</th> </tr> <tr> <th>Input Volt. 170[V]</th> <th>Input Volt. 200[V]</th> <th>Input Volt. 230[V]</th> </tr> </thead> <tbody> <tr><td>0</td><td>21.8</td><td>21.3</td><td>21.2</td></tr> <tr><td>80</td><td>108.9</td><td>108.2</td><td>107.7</td></tr> <tr><td>160</td><td>193.8</td><td>192.9</td><td>192.2</td></tr> <tr><td>240</td><td>280.0</td><td>279.0</td><td>278.1</td></tr> <tr><td>320</td><td>366.0</td><td>364.0</td><td>362.0</td></tr> <tr><td>400</td><td>452.0</td><td>449.0</td><td>447.0</td></tr> <tr><td>440</td><td>495.0</td><td>492.0</td><td>490.0</td></tr> <tr><td>--</td><td>--</td><td>--</td><td>--</td></tr> <tr><td>--</td><td>--</td><td>--</td><td>--</td></tr> <tr><td>--</td><td>--</td><td>--</td><td>--</td></tr> <tr><td>--</td><td>--</td><td>--</td><td>--</td></tr> </tbody> </table>	Load Power [W]	Input Power [W]			Input Volt. 170[V]	Input Volt. 200[V]	Input Volt. 230[V]	0	21.8	21.3	21.2	80	108.9	108.2	107.7	160	193.8	192.9	192.2	240	280.0	279.0	278.1	320	366.0	364.0	362.0	400	452.0	449.0	447.0	440	495.0	492.0	490.0	--	--	--	--	--	--	--	--	--	--	--	--	--	--	--	--
Load Power [W]	Input Power [W]																																																				
	Input Volt. 170[V]	Input Volt. 200[V]	Input Volt. 230[V]																																																		
0	21.8	21.3	21.2																																																		
80	108.9	108.2	107.7																																																		
160	193.8	192.9	192.2																																																		
240	280.0	279.0	278.1																																																		
320	366.0	364.0	362.0																																																		
400	452.0	449.0	447.0																																																		
440	495.0	492.0	490.0																																																		
--	--	--	--																																																		
--	--	--	--																																																		
--	--	--	--																																																		
--	--	--	--																																																		
<p>Note: Hatched line shows the range of the rated load power.</p>																																																					



<p>Model AME400F</p>		<p>Temperature 25°C Testing Circuitry Figure A</p>																																
Item	Efficiency (by Input Voltage)																																	
Object	_____																																	
<p>1. Graph</p> <p>---□--- Load 50% —△— Load 100%</p> <p>Efficiency [%]</p> <p>Input Voltage [V]</p>		<p>2. Value</p> <table border="1"> <thead> <tr> <th rowspan="2">Input Voltage [V]</th> <th colspan="2">Efficiency [%]</th> </tr> <tr> <th>Load 50%</th> <th>Load 100%</th> </tr> </thead> <tbody> <tr><td>170</td><td>84.4</td><td>89.0</td></tr> <tr><td>180</td><td>84.6</td><td>89.2</td></tr> <tr><td>200</td><td>84.8</td><td>89.4</td></tr> <tr><td>210</td><td>85.0</td><td>89.6</td></tr> <tr><td>220</td><td>85.1</td><td>89.8</td></tr> <tr><td>230</td><td>85.2</td><td>89.8</td></tr> <tr><td>240</td><td>85.3</td><td>89.8</td></tr> <tr><td>264</td><td>85.5</td><td>90.2</td></tr> <tr><td>280</td><td>85.5</td><td>90.2</td></tr> </tbody> </table>	Input Voltage [V]	Efficiency [%]		Load 50%	Load 100%	170	84.4	89.0	180	84.6	89.2	200	84.8	89.4	210	85.0	89.6	220	85.1	89.8	230	85.2	89.8	240	85.3	89.8	264	85.5	90.2	280	85.5	90.2
Input Voltage [V]	Efficiency [%]																																	
	Load 50%	Load 100%																																
170	84.4	89.0																																
180	84.6	89.2																																
200	84.8	89.4																																
210	85.0	89.6																																
220	85.1	89.8																																
230	85.2	89.8																																
240	85.3	89.8																																
264	85.5	90.2																																
280	85.5	90.2																																
<p>Note: Hatched line shows the input voltage range.</p>																																		



Model	AME400F
Item	Efficiency (by Load Power)
Object	_____

Temperature 25°C
Testing Circuitry Figure A

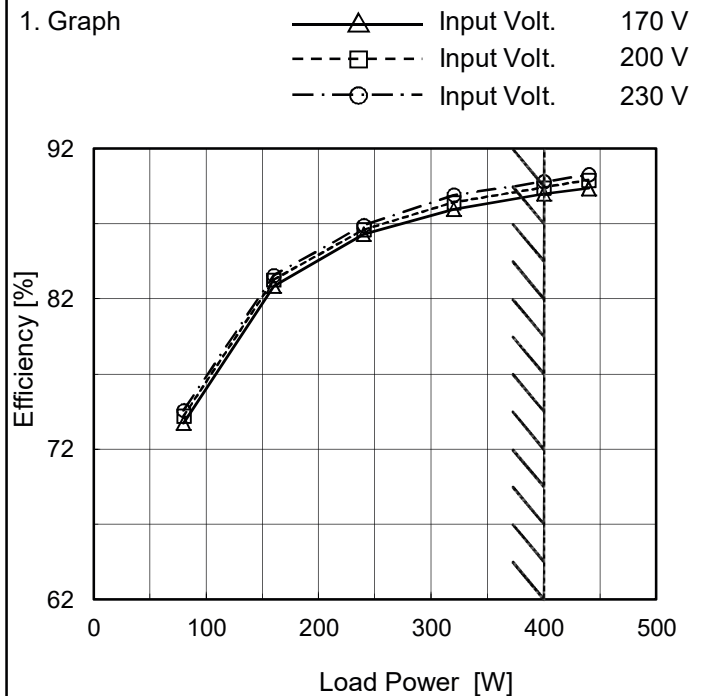

2. Value

Load Power [W]	Efficiency [%]		
	Input Volt. 170[V]	Input Volt. 200[V]	Input Volt. 230[V]
0	--	--	--
80	73.7	74.2	74.6
160	82.9	83.3	83.6
240	86.3	86.6	86.9
320	88.0	88.4	88.9
400	89.0	89.4	89.8
440	89.4	89.9	90.3
--	--	--	--
--	--	--	--
--	--	--	--
--	--	--	--

Note:
Hatched line shows the range of the rated load power.



<p>Model AME400F</p>		<p>Temperature 25°C Testing Circuitry Figure A</p>																																
<p>Item</p>	<p>Power Factor (by Input Voltage)</p>																																	
<p>Object</p>	<p>_____</p>																																	
<p>1. Graph</p> <p>---□--- Load 50% —△— Load 100%</p> <p>Note: Hatched line shows the input voltage range.</p>		<p>2. Value</p> <table border="1"> <thead> <tr> <th rowspan="2">Input Voltage [V]</th> <th colspan="2">Power Factor</th> </tr> <tr> <th>Load 50%</th> <th>Load 100%</th> </tr> </thead> <tbody> <tr><td>170</td><td>0.941</td><td>0.966</td></tr> <tr><td>180</td><td>0.939</td><td>0.964</td></tr> <tr><td>200</td><td>0.925</td><td>0.957</td></tr> <tr><td>210</td><td>0.922</td><td>0.955</td></tr> <tr><td>220</td><td>0.919</td><td>0.953</td></tr> <tr><td>230</td><td>0.913</td><td>0.953</td></tr> <tr><td>240</td><td>0.906</td><td>0.951</td></tr> <tr><td>264</td><td>0.890</td><td>0.941</td></tr> <tr><td>280</td><td>0.405</td><td>0.588</td></tr> </tbody> </table>	Input Voltage [V]	Power Factor		Load 50%	Load 100%	170	0.941	0.966	180	0.939	0.964	200	0.925	0.957	210	0.922	0.955	220	0.919	0.953	230	0.913	0.953	240	0.906	0.951	264	0.890	0.941	280	0.405	0.588
Input Voltage [V]	Power Factor																																	
	Load 50%	Load 100%																																
170	0.941	0.966																																
180	0.939	0.964																																
200	0.925	0.957																																
210	0.922	0.955																																
220	0.919	0.953																																
230	0.913	0.953																																
240	0.906	0.951																																
264	0.890	0.941																																
280	0.405	0.588																																



<p>Model AME400F</p>		<p>Temperature 25°C Testing Circuitry Figure A</p>																																																			
Item	Power Factor (by Load Power)																																																				
Object	_____																																																				
<p>1. Graph</p> <p> —△— Input Volt. 170 V - - - □ - - - Input Volt. 200 V - · - ○ - · - - Input Volt. 230 V </p> <p>Power Factor</p> <p>Load Power [W]</p>		<p>2. Value</p> <table border="1"> <thead> <tr> <th rowspan="2">Load Power [W]</th> <th colspan="3">Power Factor</th> </tr> <tr> <th>Input Volt. 170[V]</th> <th>Input Volt. 200[V]</th> <th>Input Volt. 230[V]</th> </tr> </thead> <tbody> <tr><td>0</td><td>0.651</td><td>0.570</td><td>0.487</td></tr> <tr><td>80</td><td>0.885</td><td>0.857</td><td>0.830</td></tr> <tr><td>160</td><td>0.930</td><td>0.914</td><td>0.895</td></tr> <tr><td>240</td><td>0.946</td><td>0.936</td><td>0.926</td></tr> <tr><td>320</td><td>0.961</td><td>0.950</td><td>0.940</td></tr> <tr><td>400</td><td>0.966</td><td>0.957</td><td>0.953</td></tr> <tr><td>440</td><td>0.967</td><td>0.961</td><td>0.955</td></tr> <tr><td>--</td><td>--</td><td>--</td><td>--</td></tr> <tr><td>--</td><td>--</td><td>--</td><td>--</td></tr> <tr><td>--</td><td>--</td><td>--</td><td>--</td></tr> <tr><td>--</td><td>--</td><td>--</td><td>--</td></tr> </tbody> </table>	Load Power [W]	Power Factor			Input Volt. 170[V]	Input Volt. 200[V]	Input Volt. 230[V]	0	0.651	0.570	0.487	80	0.885	0.857	0.830	160	0.930	0.914	0.895	240	0.946	0.936	0.926	320	0.961	0.950	0.940	400	0.966	0.957	0.953	440	0.967	0.961	0.955	--	--	--	--	--	--	--	--	--	--	--	--	--	--	--	--
Load Power [W]	Power Factor																																																				
	Input Volt. 170[V]	Input Volt. 200[V]	Input Volt. 230[V]																																																		
0	0.651	0.570	0.487																																																		
80	0.885	0.857	0.830																																																		
160	0.930	0.914	0.895																																																		
240	0.946	0.936	0.926																																																		
320	0.961	0.950	0.940																																																		
400	0.966	0.957	0.953																																																		
440	0.967	0.961	0.955																																																		
--	--	--	--																																																		
--	--	--	--																																																		
--	--	--	--																																																		
--	--	--	--																																																		
<p>Note: Hatched line shows the range of the rated load power.</p>																																																					



Model		AME400F	Temperature 25°C Testing Circuitry Figure A
Item		Inrush Current	
Object		_____	

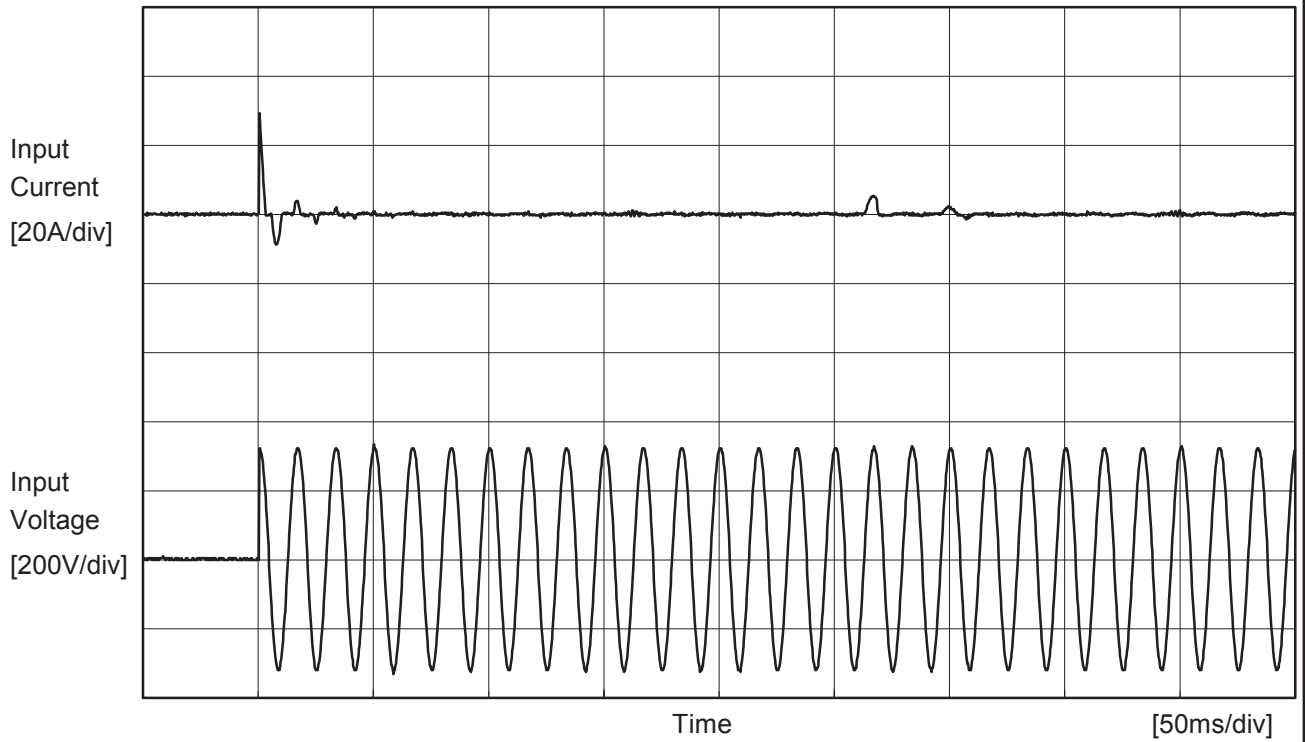

Input Voltage	200 V
Frequency	60 Hz
Load	100 %
Primary inrush current	29.4 A
Secondary inrush current	5.4 A

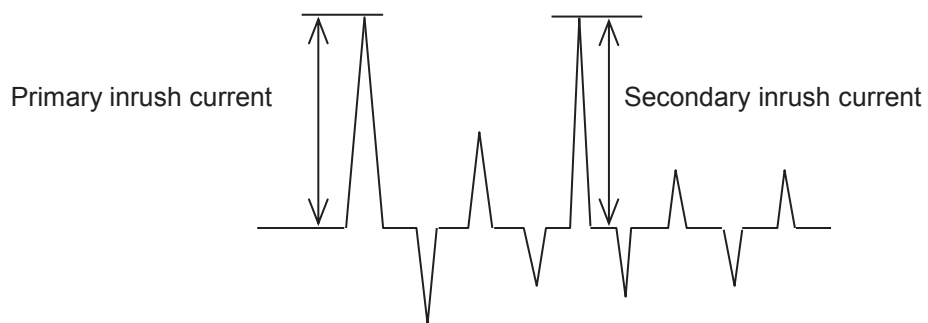



COSEL		Temperature 25°C Testing Circuitry Figure B
Model	AME400F	
Item	Leakage Current	
Object	_____	

Standards	Testing Circuitry	Measuring Method	Input Volt.			Note
			170 [V]	200 [V]	230 [V]	
DEN-AN	Figure B-1	Both phases	0.12	0.15	0.17	Operation
		One of phases	0.24	0.27	0.31	Stand by
IEC62368-1	Figure B-2	Both phases	0.13	0.15	0.17	Operation
		One of phases	0.24	0.27	0.31	Stand by
	Figure B-3	Both phases	0.12	0.15	0.17	Operation
		One of phases	0.23	0.27	0.31	Stand by
IEC60601-1	Figure B-4	Both phases	0.12	0.15	0.17	Operation
		One of phases	0.24	0.27	0.31	Stand by

Note:

The value of "One of phases" is for reference only.
 The above value is the larger one of each phase of AC input.

COSEL			
Model	AME400F	Temperature	25°C
Item	Rise and Fall Time	Testing Circuitry	Figure A
Object	_____		

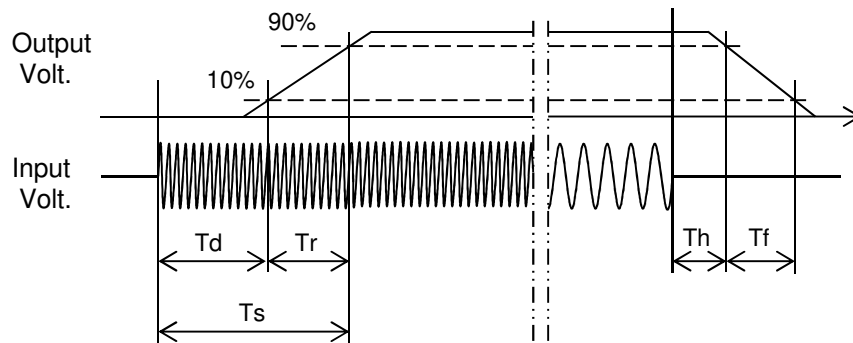

Input Voltage 230V
 Load Power 100%

[ms]

Time	T_d	T_r	T_s	T_h	T_f
MODULE					
120W, SINGLE	788	6	794	23	1 - 9
240W, SINGLE	784	5	789	22	0 - 5
150W, DUAL	784	4	788	24	0.6



<p>Model AME400F</p>		<p>Temperature 25°C Testing Circuitry Figure A</p>																																																			
<p>Item</p>	<p>Hold-up Time</p>																																																				
<p>Object</p>	<p>2. Value</p>																																																				
<p>1. Graph</p> <p> Input Volt. 170V Input Volt. 200V Input Volt. 230V </p>																																																					
<p>Note:</p> <p>Hatched line shows the range of the rated load power.</p> <p>"Hold-up time" is the amount of time a power supply can maintain output voltage within the range of the output voltage accuracy after a loss of input power.</p>		<table border="1"> <thead> <tr> <th rowspan="2">Load Power [W]</th> <th colspan="3">Hold-up Time [ms]</th> </tr> <tr> <th>Input Volt. 170[V]</th> <th>Input Volt. 200[V]</th> <th>Input Volt. 230[V]</th> </tr> </thead> <tbody> <tr><td>0</td><td>--</td><td>--</td><td>--</td></tr> <tr><td>80</td><td>84</td><td>84</td><td>84</td></tr> <tr><td>160</td><td>46</td><td>45</td><td>45</td></tr> <tr><td>240</td><td>31</td><td>31</td><td>31</td></tr> <tr><td>320</td><td>23</td><td>23</td><td>23</td></tr> <tr><td>400</td><td>18</td><td>18</td><td>18</td></tr> <tr><td>440</td><td>17</td><td>16</td><td>16</td></tr> <tr><td>--</td><td>--</td><td>--</td><td>--</td></tr> <tr><td>--</td><td>--</td><td>--</td><td>--</td></tr> <tr><td>--</td><td>--</td><td>--</td><td>--</td></tr> <tr><td>--</td><td>--</td><td>--</td><td>--</td></tr> </tbody> </table>	Load Power [W]	Hold-up Time [ms]			Input Volt. 170[V]	Input Volt. 200[V]	Input Volt. 230[V]	0	--	--	--	80	84	84	84	160	46	45	45	240	31	31	31	320	23	23	23	400	18	18	18	440	17	16	16	--	--	--	--	--	--	--	--	--	--	--	--	--	--	--	--
Load Power [W]	Hold-up Time [ms]																																																				
	Input Volt. 170[V]	Input Volt. 200[V]	Input Volt. 230[V]																																																		
0	--	--	--																																																		
80	84	84	84																																																		
160	46	45	45																																																		
240	31	31	31																																																		
320	23	23	23																																																		
400	18	18	18																																																		
440	17	16	16																																																		
--	--	--	--																																																		
--	--	--	--																																																		
--	--	--	--																																																		
--	--	--	--																																																		



<p>Model AME400F</p>		<p>Temperature 25°C</p>																																																				
<p>Item Instantaneous Interruption Compensation</p>		<p>Testing Circuitry Figure A</p>																																																				
<p>Object _____</p>																																																						
<p>1. Graph</p> <p> —△— Input Volt. 170V - - -□- - - Input Volt. 200V - · - ○ - · - Input Volt. 230V </p> <p>Instantaneous Compensation Time [ms]</p> <p>Load Power [W]</p>		<p>2. Value</p> <table border="1"> <thead> <tr> <th rowspan="2">Load Power [W]</th> <th colspan="3">Time [ms]</th> </tr> <tr> <th>Input Volt. 170[V]</th> <th>Input Volt. 200[V]</th> <th>Input Volt. 230[V]</th> </tr> </thead> <tbody> <tr><td>0</td><td>--</td><td>--</td><td>--</td></tr> <tr><td>80</td><td>89</td><td>89</td><td>89</td></tr> <tr><td>160</td><td>47</td><td>48</td><td>48</td></tr> <tr><td>240</td><td>31</td><td>31</td><td>31</td></tr> <tr><td>320</td><td>23</td><td>23</td><td>23</td></tr> <tr><td>400</td><td>19</td><td>19</td><td>19</td></tr> <tr><td>440</td><td>16</td><td>16</td><td>16</td></tr> <tr><td>--</td><td>--</td><td>--</td><td>--</td></tr> <tr><td>--</td><td>--</td><td>--</td><td>--</td></tr> <tr><td>--</td><td>--</td><td>--</td><td>--</td></tr> <tr><td>--</td><td>--</td><td>--</td><td>--</td></tr> </tbody> </table>		Load Power [W]	Time [ms]			Input Volt. 170[V]	Input Volt. 200[V]	Input Volt. 230[V]	0	--	--	--	80	89	89	89	160	47	48	48	240	31	31	31	320	23	23	23	400	19	19	19	440	16	16	16	--	--	--	--	--	--	--	--	--	--	--	--	--	--	--	--
Load Power [W]	Time [ms]																																																					
	Input Volt. 170[V]	Input Volt. 200[V]	Input Volt. 230[V]																																																			
0	--	--	--																																																			
80	89	89	89																																																			
160	47	48	48																																																			
240	31	31	31																																																			
320	23	23	23																																																			
400	19	19	19																																																			
440	16	16	16																																																			
--	--	--	--																																																			
--	--	--	--																																																			
--	--	--	--																																																			
--	--	--	--																																																			
<p>Note: Hatched line shows the range of the rated load power.</p>																																																						



Model	AME400F
Item	Minimum Input Voltage for Regulated Output Voltage
Object	_____

Testing Circuitry Figure A

1. Graph

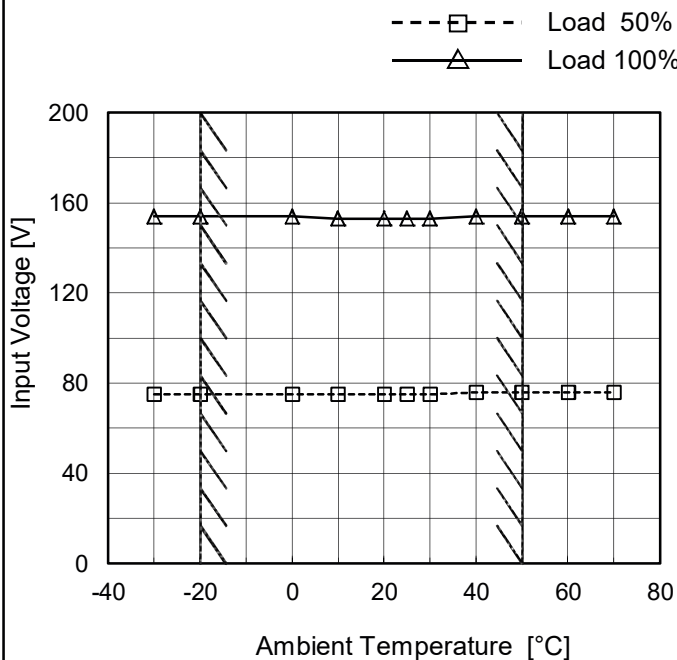

2. Value

Ambient Temperature [°C]	Input Voltage [V]	
	Load 50%	Load 100%
-30	75	154
-20	75	154
0	75	154
10	75	153
20	75	153
25	75	153
30	75	153
40	76	154
50	76	154
60	76	154
70	76	154

Note:
 Hatched line shows the range of the rated operating temperature.

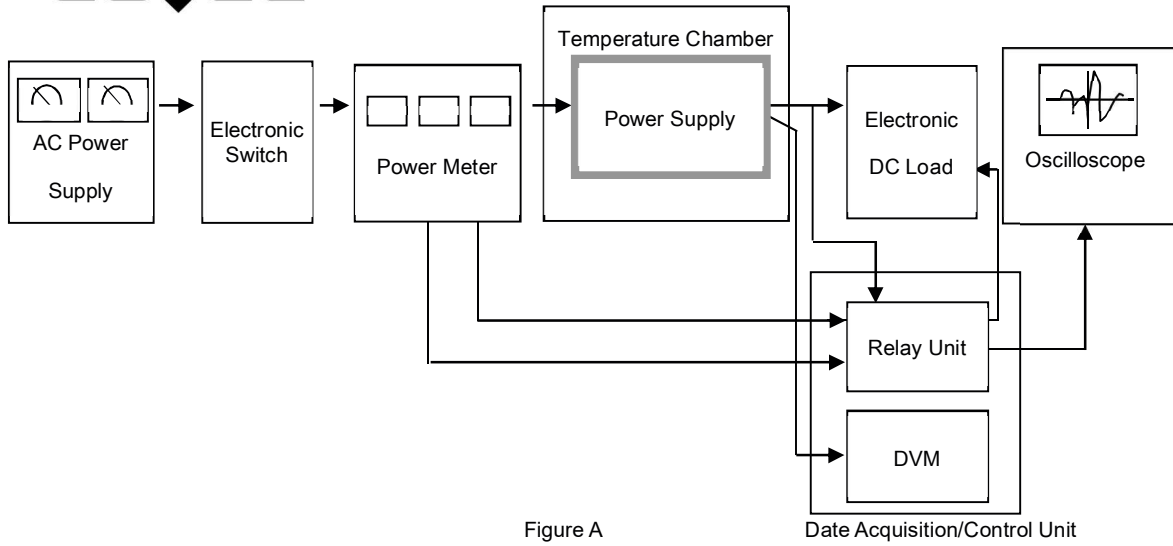

Figure A

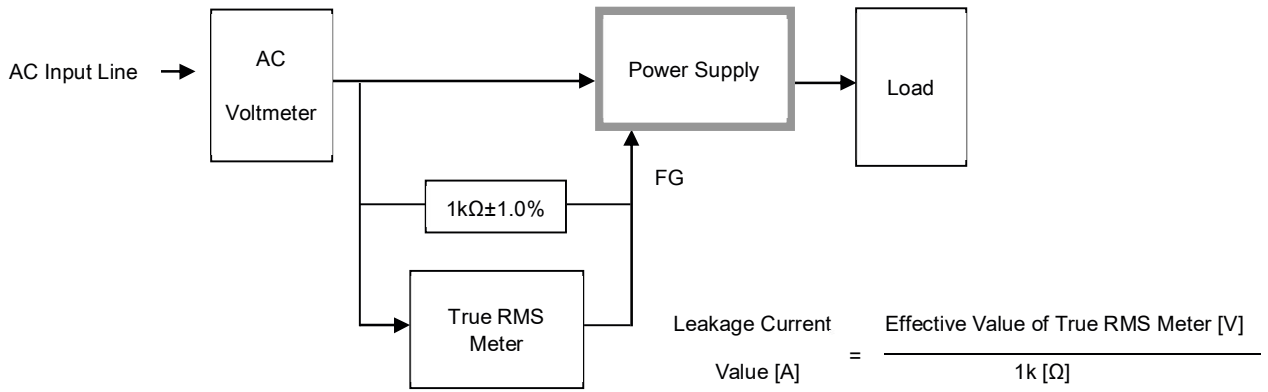

Figure B-1 (DEN-AN)

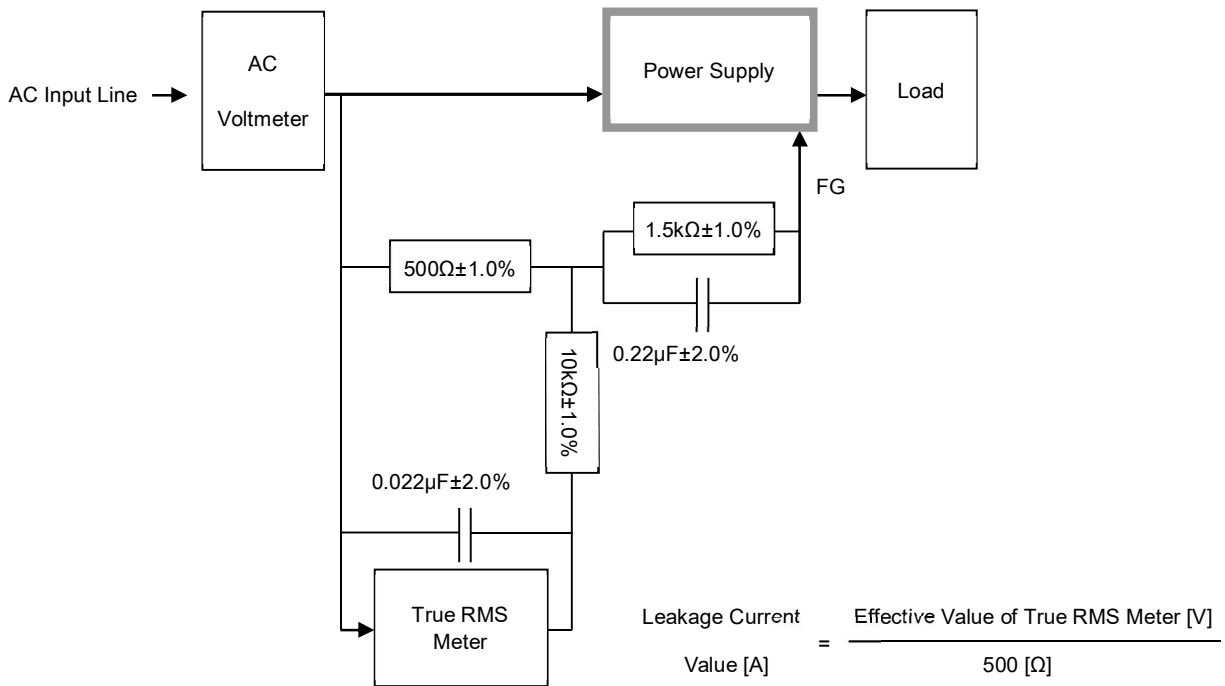

Figure B-2 (IEC62368-1 refer to IEC60990 Fig.4)

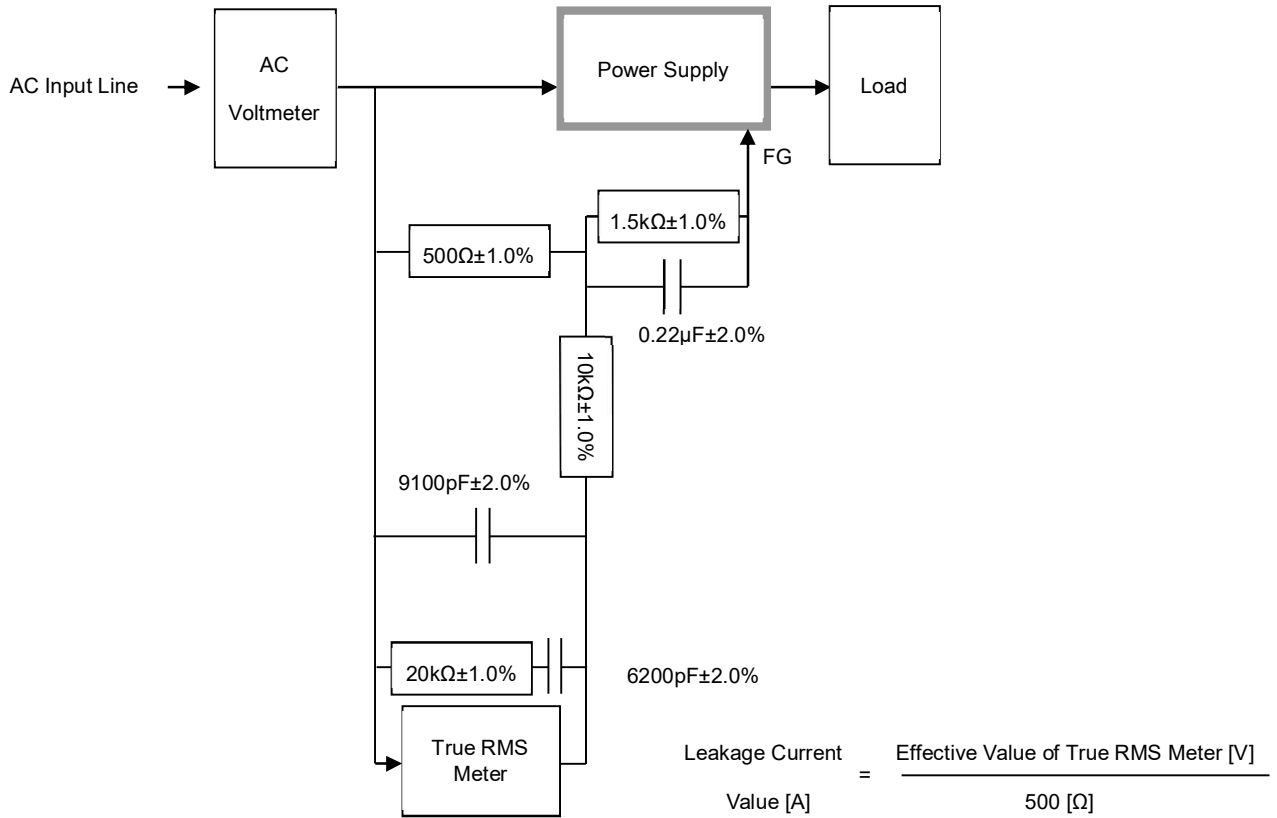

Figure B-3 (IEC62368-1 refer to IEC60990 Fig.5)

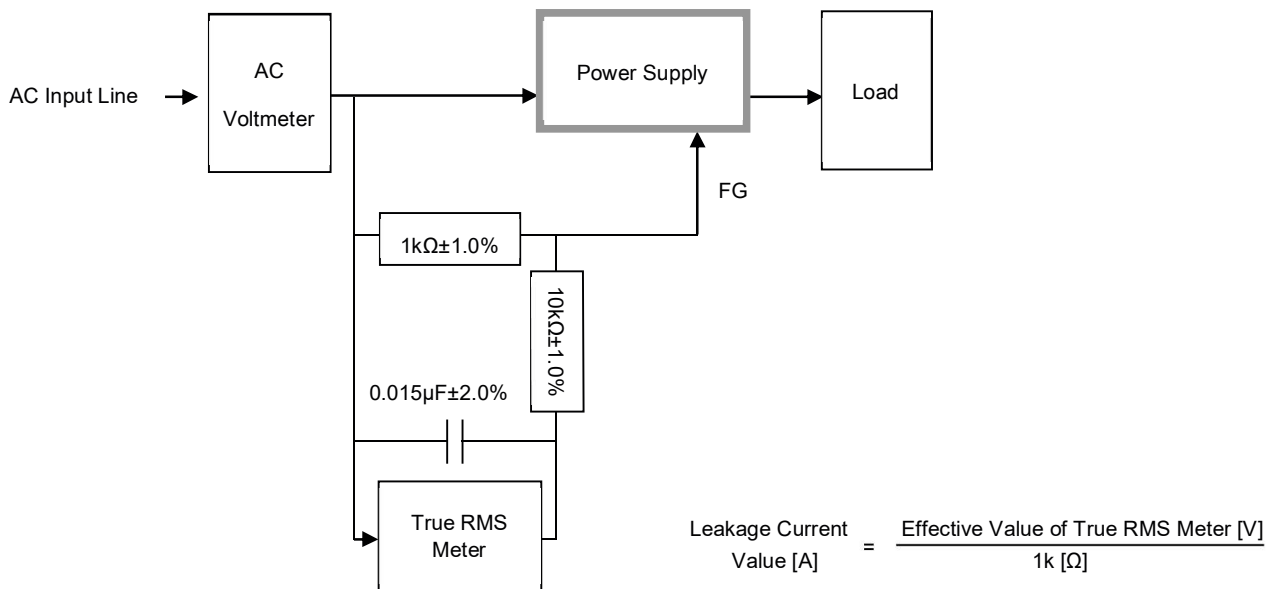

Figure B-4 (IEC60601-1)