

DATA SHEET		Date	04-Oct-07
Model	SFS304802	Temp.	25 degreeC
Test	EMI Line conduction & Radiated emission	Humid.	45 %RH
		Tested by	Y.Miyawaki

**LINE CONDUCTION**

Model Name : SFS304802 Temp. : 25degreeC  
 Model No. : Humi. : 45%  
 Serial No. : Date : 2007/10/4 10:20  
 Points : 3 Test Equip. : R3132,ESPC  
 Detector : PEAK/QP/Ave. Load Line : 100mm  
 Line Mode : VA/VB Comment : Vo = 2.0V , Io = 9.0A  
 Power Supply : DC 48V  
 Limit1: [CISPR Pub11] Class A Gr.1(QP)  
 Limit2: [CISPR Pub11] Class A Gr.1(Ave.)

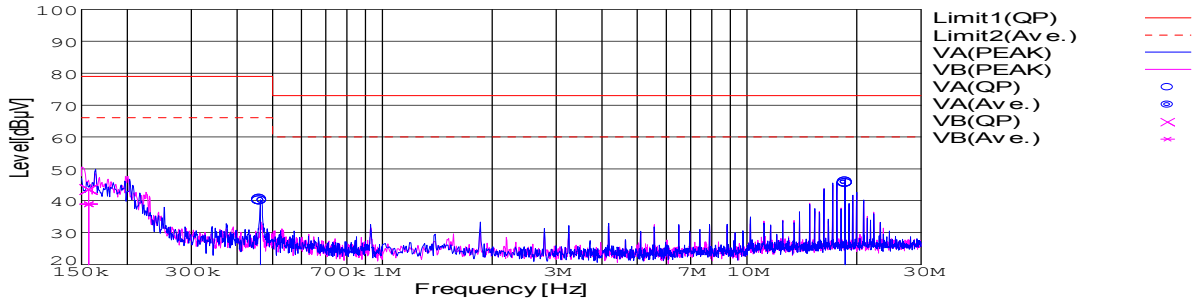

Frequency [MHz]	Meter Reading (Ave.) [dBuV]	Meter Reading (QP) [dBuV]	Factor [dB]	Level(Ave.) [dBuV]	Level(QP) [dBuV]	Line	Limit(Ave.) [dBuV]	Limit(QP) [dBuV]	Margin(Ave.) [dB]	Margin(QP) [dB]
0.4632	30.2	30.3	9.9	40.1	40.2	VA	66	79	25.9	38.8
18.5597	35.4	35.6	10.2	45.6	45.8	VA	60	73	14.4	27.2
0.1567	29.1	33.7	9.8	38.9	43.5	VB	66	79	27.1	35.5

**RADIATED EMISSION**

Model Name : SFS304802 Temp. : 25degreeC  
 Model No. : Humi. : 45%  
 Serial No. : Date : 2007/10/4 16:24  
 Points : 3 Test Equip. : R3132,ESPC  
 Detector : PEAK/QP Load Line : 100mm  
 Polarization : Vertical Comment : Vo = 2.0V , Io = 9.0A  
 Power Supply : DC 48V  
 Limit: [CISPR 11] Class A Group 1<3m>

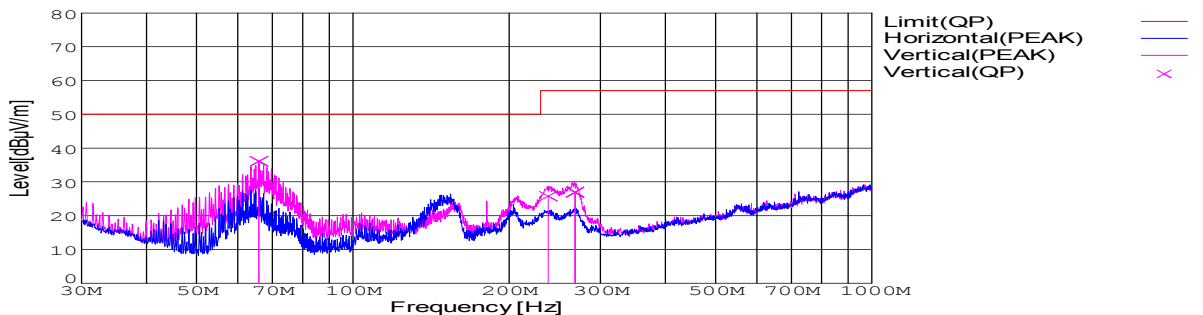

Frequency [MHz]	Meter Reading (QP) [dBuV]	Ant. Type	Antenna Factor [dB/m]	Cable & Preamp [dB]	Level(QP) [dBuV/m]	Angle [°]	Height [cm]	Polar.	Limit [dBuV/m]	Margin [dB]
65.939	63.2	BL	4.9	-32	36.1	316	123	Vert.	50	13.9
267.928	45.2	BL	12.8	-31.1	26.9	238	139	Vert.	57	30.1
237.911	46.2	BL	10.8	-31.2	25.8	209	135	Vert.	57	31.2

DATA SHEET		Date	04-Oct-07
Model	SFS304802	Temp.	25 degreeC
Test	EMI Line conduction & Radiated emission	Humid.	45 %RH
		Tested by	Y.Miyawaki

## 1. Conditions

### (1) Photograph of Test Set-Up

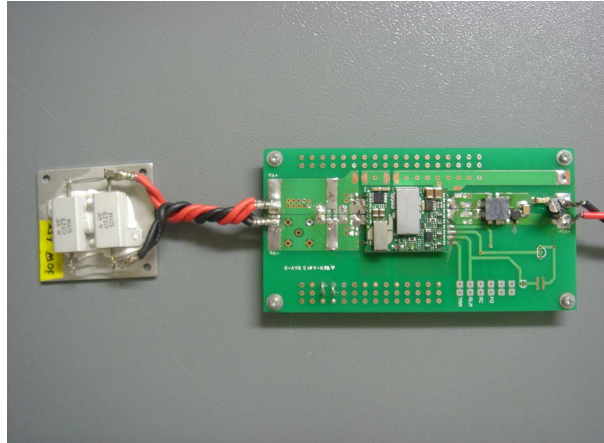
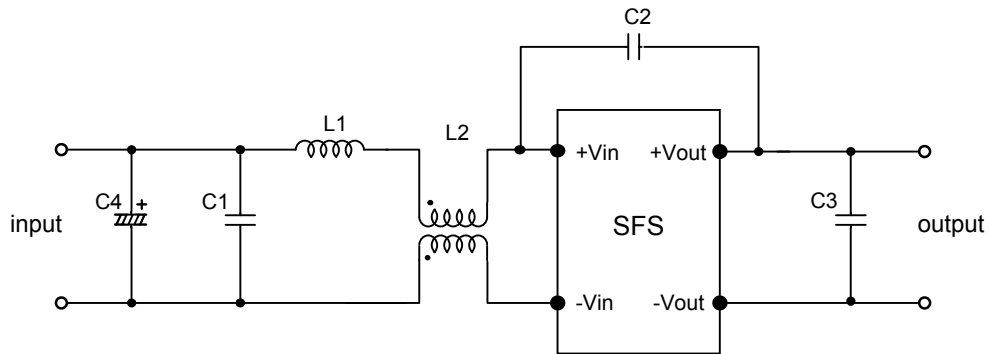

Fig1. Photograph of Test Set-Up

### (2) Testing circuitry



C1: 1 $\mu$ F 100V Ceramic capacitor  
 C2: 2200pF 630V Ceramic capacitor  
 C3: 22 $\mu$ F 16V Ceramic capacitor  
 C4: 22 $\mu$ F 100V Electric capacitor

L1: 1 $\mu$ H 2.4A Inductor  
 L2: ACM1211-102-2PL : TDK

Fig2. Testing circuitry

DATA SHEET		Date	04-Oct-07
Model	Circuit used for measurement	Temp.	25 degreeC
Test	EMI Line conduction & Radiated emission	Humid.	45 %RH
		Tested by	Y.Miyawaki

## 1. Line conduction

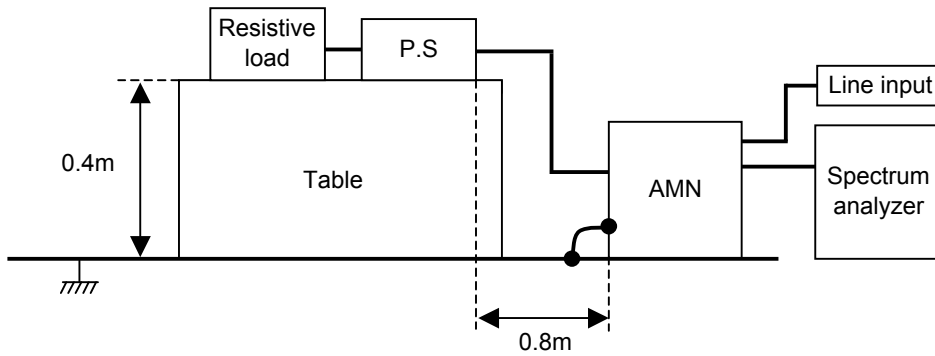

## 2. Radiated emission

