

DATA SHEET		Date	09-Oct-07
Model	SFS30241R2	Temp.	25 degreeC
Test	EMI Line conduction & Radiated emission	Humid.	45 %RH
		Tested by	Y.Miyawaki

LINE CONDUCTION

Model Name : SFS30241R2 Temp. : 25degreeC
 Model No. : Humi. : 45%
 Serial No. : Date : 2007/10/9 21:20
 Points : 3 Test Equip. : R3132,ESPC
 Detector : PEAK/QP/Ave. Load Line : 100mm
 Line Mode : VA Comment : Vo = 1.2V , Io = 10.4A
 Power Supply : DC 24V
 Limit1: [CISPR Pub11] Class A Gr.1(QP)
 Limit2: [CISPR Pub11] Class A Gr.1(Ave.)

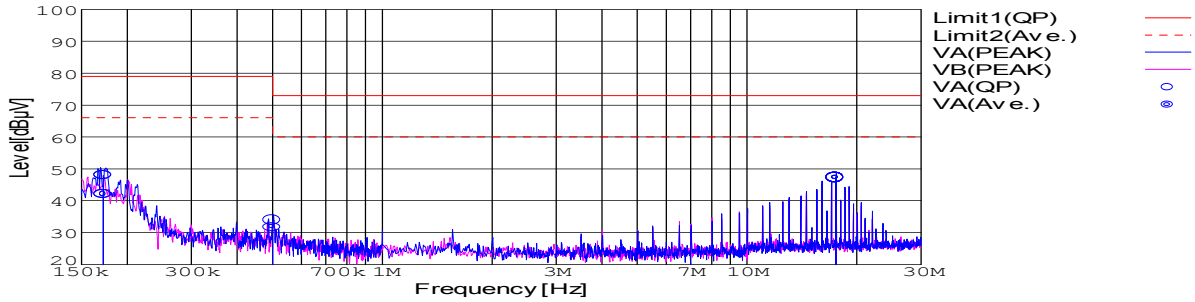

Frequency [MHz]	Meter Reading (Ave.) [dBuV]	Meter Reading (QP) [dBuV]	Factor [dB]	Level(Ave.) [dBuV]	Level(QP) [dBuV]	Line	Limit(Ave.) [dBuV]	Limit(QP) [dBuV]	Margin(Ave.) [dB]	Margin(QP) [dB]
0.172	32.2	38.1	9.8	42	47.9	VA	66	79	24	31.1
0.5007	21.9	23.9	9.9	31.8	33.8	VA	60	73	28.2	39.2
17.5256	37	37.1	10.2	47.2	47.3	VA	60	73	12.8	25.7

RADIATED EMISSION

Model Name : SFS30241R2 Temp. : 25degreeC
 Model No. : Humi. : 45%
 Serial No. : Date : 2007/10/9 21:31
 Points : 3 Test Equip. : R3132,ESPC
 Detector : PEAK/QP Load Line : 100mm
 Polarization : Vertical Comment : Vo = 1.2V , Io = 10.4A
 Power Supply : DC 24V
 Limit: [CISPR 11] Class A Group 1<3m>

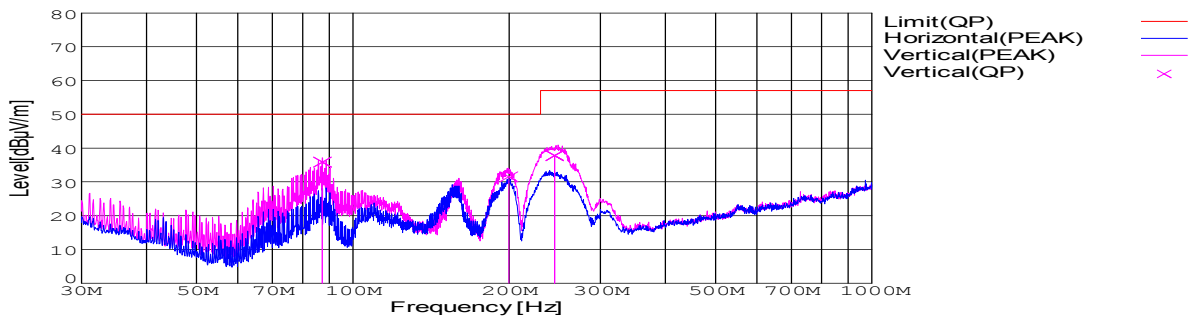

Frequency [MHz]	Meter Reading (QP) [dBuV]	Ant. Type	Antenna Factor [dB/m]	Cable & Preamp [dB]	Level(QP) [dBuV/m]	Angle [°]	Height [cm]	Polar.	Limit [dBuV/m]	Margin [dB]
87.298	59.5	BL	8.2	-31.9	35.8	68	117	Vert.	50	14.2
199.699	54.3	BL	8.5	-31.3	31.5	161	107	Vert.	50	18.5
244.858	57.2	BL	11.7	-31.1	37.8	208	111	Vert.	57	19.2

DATA SHEET		Date	09-Oct-07
Model	SFS30241R2	Temp.	25 degreeC
Test	EMI Line conduction & Radiated emission	Humid.	45 %RH
		Tested by	Y.Miyawaki

1. Conditions

(1) Photograph of Test Set-Up

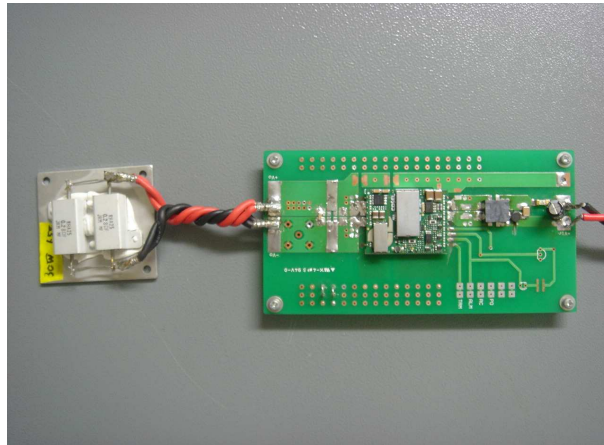
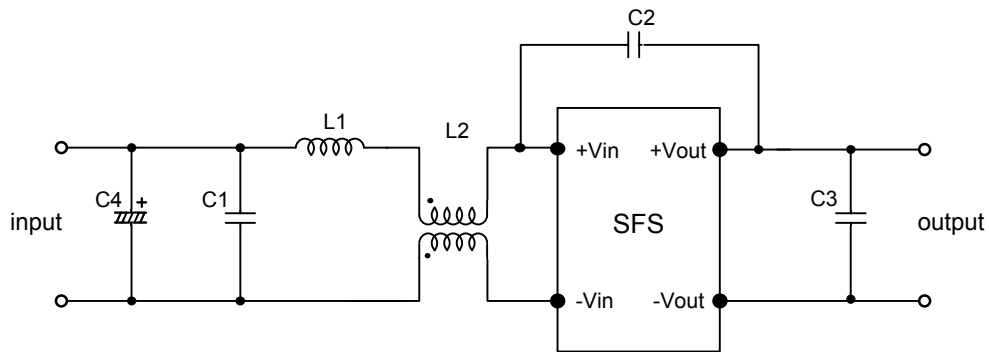

Fig1. Photograph of Test Set-Up

(2) Testing circuitry



C1: 1 μ F 100V Ceramic capacitor
 C2: 2200pF 630V Ceramic capacitor
 C3: 22 μ F 16V Ceramic capacitor
 C4: 68 μ F 80V Electric capacitor

L1: 1 μ H 2.4A Inductor
 L2: ACM1211-102-2PL : TDK

Fig2. Testing circuitry

DATA SHEET		Date	09-Oct-07
Model	Circuit used for measurement	Temp.	25 degreeC
Test	EMI Line conduction & Radiated emission	Humid.	45 %RH
		Tested by	Y.Miyawaki

1. Line conduction

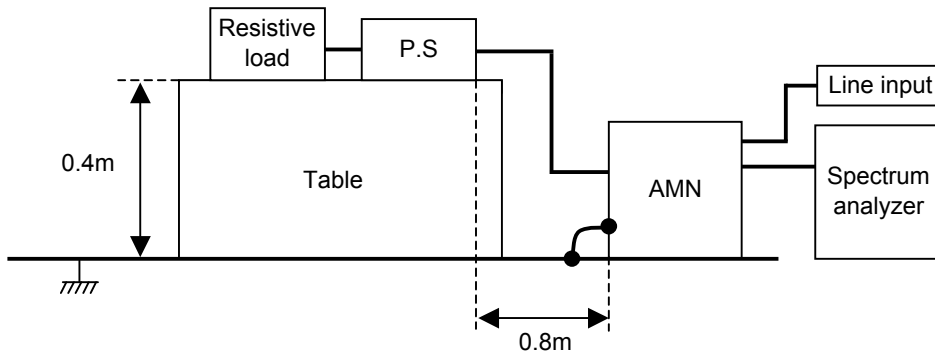

2. Radiated emission

