

DATA SHEET		Date	05-Oct-07
Model	SFS302415	Temp.	25 degreeC
Test	EMI Line conduction & Radiated emission	Humid.	45 %RH
		Tested by	Y.Miyawaki

LINE CONDUCTION

Model Name : SFS302415 Temp. : 25degreeC
 Model No. : Humi. : 45%
 Serial No. : Date : 2007/10/5 16:58
 Points : 3 Test Equip. : R3132,ESPC
 Detector : PEAK/QP/Ave. Load Line : 100mm
 Line Mode : VA/VB Comment : Vo = 15.0V , Io = 2.0A
 Power Supply : DC 24V
 Limit1: [CISPR Pub11] Class A Gr.1(QP)
 Limit2: [CISPR Pub11] Class A Gr.1(Ave.)

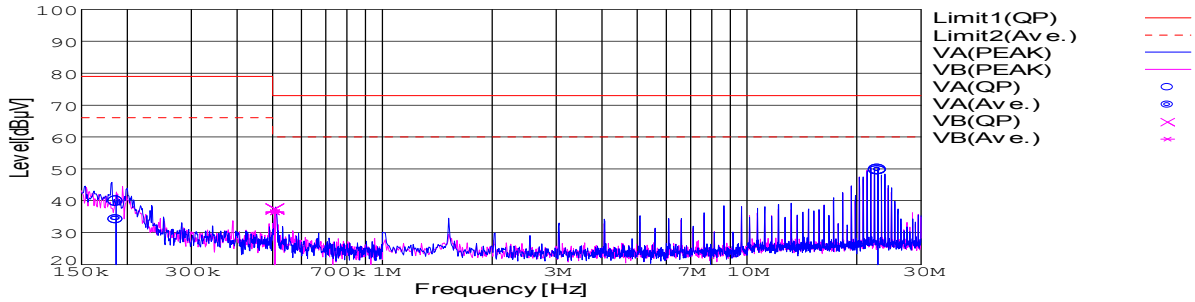

Frequency [MHz]	Meter Reading (Ave.) [dBuV]	Meter Reading (QP) [dBuV]	Factor [dB]	Level(Ave.) [dBuV]	Level(QP) [dBuV]	Line	Limit(Ave.) [dBuV]	Limit(QP) [dBuV]	Margin(Ave.) [dB]	Margin(QP) [dB]
0.1863	24.5	30	9.8	34.3	39.8	VA	66	79	31.7	39.2
22.8123	39.4	39.3	10.3	49.7	49.6	VA	60	73	10.3	23.4
0.5077	26.5	27.5	9.9	36.4	37.4	VB	60	73	23.6	35.6

RADIATED EMISSION

Model Name : SFS302415 Temp. : 25degreeC
 Model No. : Humi. : 45%
 Serial No. : Date : 2007/10/5 17:32
 Points : 3 Test Equip. : R3132,ESPC
 Detector : PEAK/QP Load Line : 100mm
 Polarization : Vertical Comment : Vo = 15.0V , Io = 2.0A
 Power Supply : DC 24V
 Limit: [CISPR 11] Class A Group 1<3m>

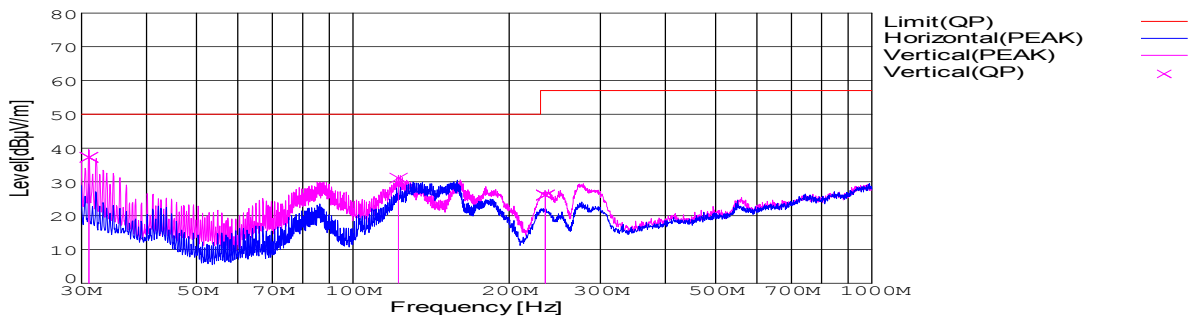

Frequency [MHz]	Meter Reading (QP) [dBuV]	Ant. Type	Antenna Factor [dB/m]	Cable & Preamp [dB]	Level(QP) [dBuV/m]	Angle [°]	Height [cm]	Polar.	Limit [dBuV/m]	Margin [dB]
31.001	51.9	BL	17.7	-32.3	37.3	107	100	Vert.	50	12.7
122.508	51.8	BL	11	-31.7	31.1	3	158	Vert.	50	18.9
234.773	46.9	BL	10.4	-31.2	26.1	203	129	Vert.	57	30.9

DATA SHEET		Date	05-Oct-07
Model	SFS302415	Temp.	25 degreeC
Test	EMI Line conduction & Radiated emission	Humid.	45 %RH
		Tested by	Y.Miyawaki

1. Conditions

(1) Photograph of Test Set-Up

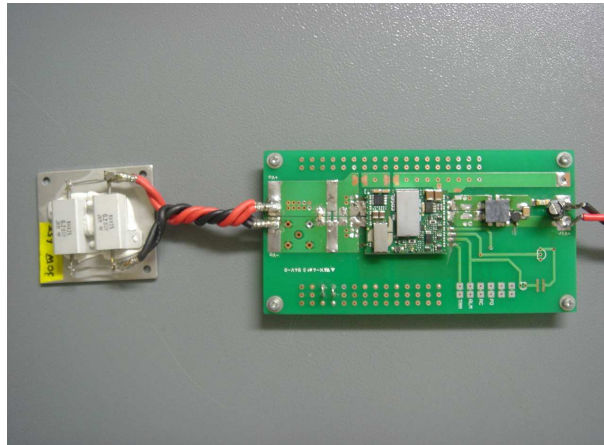
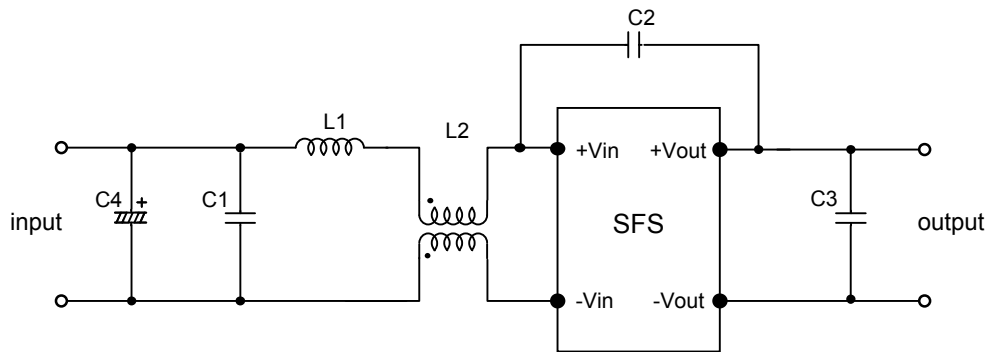

Fig1. Photograph of Test Set-Up

(2) Testing circuitry



C1: 1 μ F 100V Ceramic capacitor
 C2: 2200pF 630V Ceramic capacitor
 C3: 0.1 μ F 50V Ceramic capacitor
 C4: 68 μ F 80V Electric capacitor

L1: 1 μ H 2.4A Inductor
 L2: ACM1211-102-2PL : TDK

Fig2. Testing circuitry

DATA SHEET		Date	05-Oct-07
Model	Circuit used for measurement	Temp.	25 degreeC
Test	EMI Line conduction & Radiated emission	Humid.	45 %RH
		Tested by	Y.Miyawaki

1. Line conduction

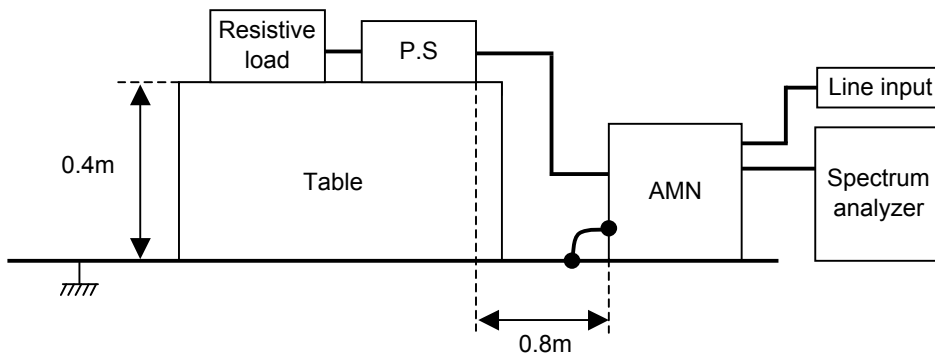

2. Radiated emission

