

# TAH series

TAH -10 -683 -□

① ② ③ ④

- ① Model Name
- ② Rated Current
- ③ Line to ground capacitor code: See table 1.1.

table 1.1 Line to ground capacitor code

Code	Leakage Current (Input 250/500V 60Hz)	Line to ground capacitor (nominal value)
683	2.5mA/5.0mA max	68000pF

- ④ Options
- D: DIN rail installation type

\* The dimensions change when the option is set. Refer to External view.



RoHS

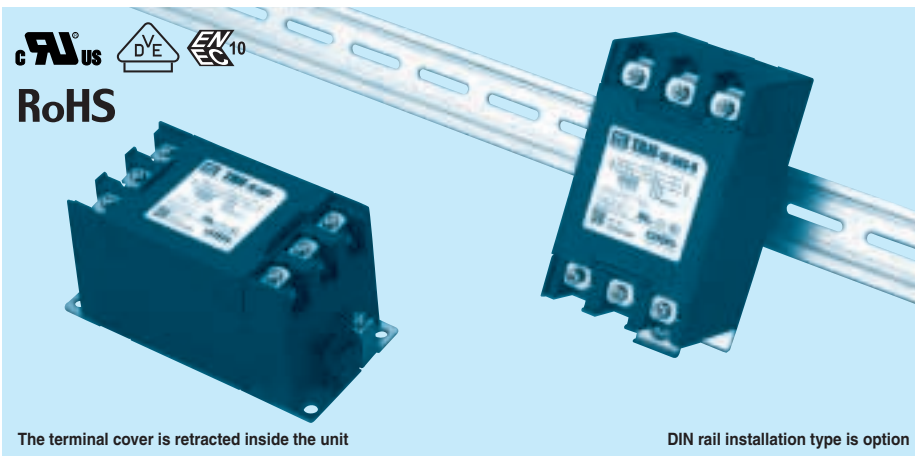

The terminal cover is retracted inside the unit

DIN rail installation type is option

## Features of TAH series

### Ultra high-attenuation type of common mode noise from 10kHz to 1MHz

· Three Phase 500 VAC

· Quick and easy push-down terminal

Just connect the wires, push down and tighten the screws with a screwdriver

## Specifications

No.	Items	TAH-04-683	TAH-06-683	TAH-10-683	TAH-20-683	TAH-30-683
1	Rated Voltage[V]	AC Three Phase 500				
2	Rated Current[A]	4	6	10	20	30
3	Test Voltage (Terminal-Mounting Plate)	2,000 VAC (Cutoff Current = 100mA), 1minute at room temperature and humidity				
4	Isolation Resistance (Terminal-Mounting Plate)	500 VDC 100MΩ minute at room temperature and humidity				
5	Leakage current 250/500V 60Hz	2.5mA/5.0mA max				
6	Voltage drop	1.5V max		1.0V max		
7	Safety agency approval temperatures	-25 to +85°C (Refer to Derating Curve)				
8	Operating temperature	-40 to +85°C (Refer to Derating Curve)				
9	Operating humidity	20 to 95%RH (Non condensing)				
10	Storage temperature/humidity	-40 to +85°C/20 to 95%RH (Non condensing)				
11	Vibration	10 to 55Hz, 19.6m/s <sup>2</sup> (2G), 3min. Period, 1hour each X, Y and Z axis				
12	Impact	196.1m/s <sup>2</sup> (20G), 11ms Once each X, Y and Z axis				
13	Safety agency approvals	UL1283, CSA C22.2 No.8 (C-UL) , DIN EN60939 VDE0565 Teil3-1, ENEC				
14	Case size (without projection) /Mass	63 X 64 X 128 mm (W X H X D) /620g max (Option : -D refer to external view)				

## Circuit Diagram

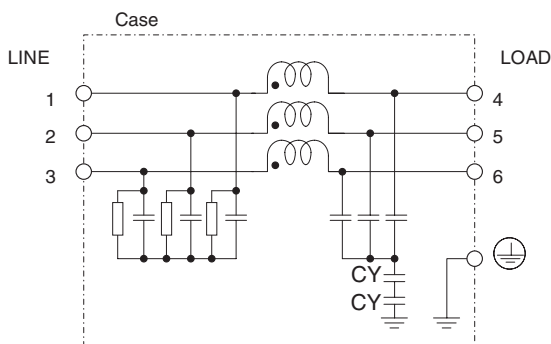

CY : Line to ground capacitor ⊥ : Mounting Plate

## Derating Curve

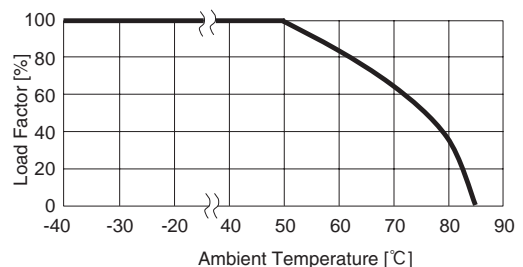

## External view

This product is shipped in the following condition, because it is equipped with push-down terminals.

- ① The terminal cover is retracted inside the unit.
- ② The screws for connecting the terminals are held in the up right position.

### Standard Type

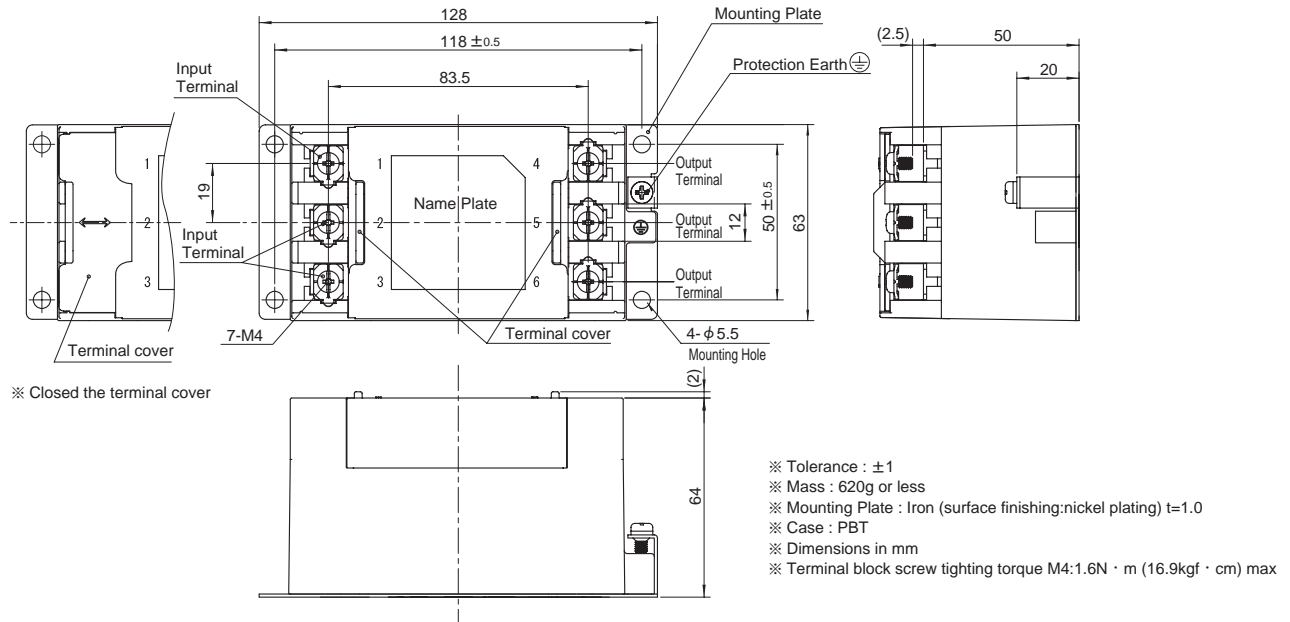

### DIN rail installation Type

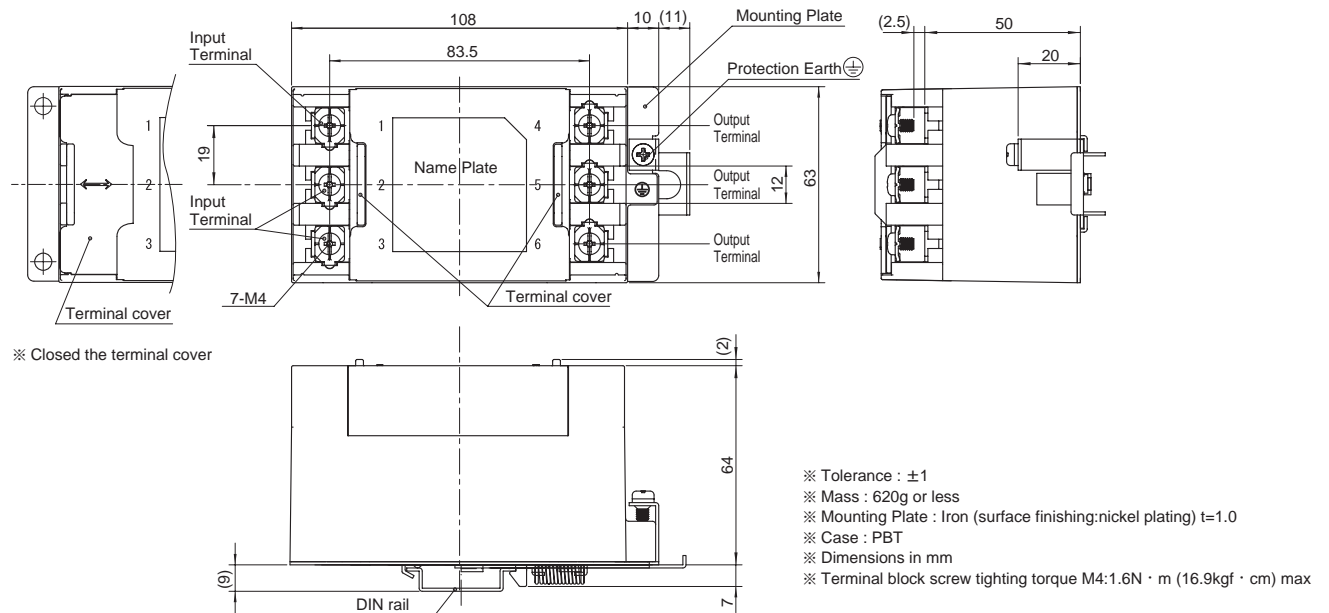

### ■ Note when installing the noise filter on a DIN rail.

When the noise filter is grounded through the DIN rail, the proper noise attenuation may not be achieved.

Be sure to connect the protection earth (PE) of the noise filter body to the earth.

