

SFCS15

SFC S 15 24 3R3 C

① ② ③ ④ ⑤ ⑥



RoHS

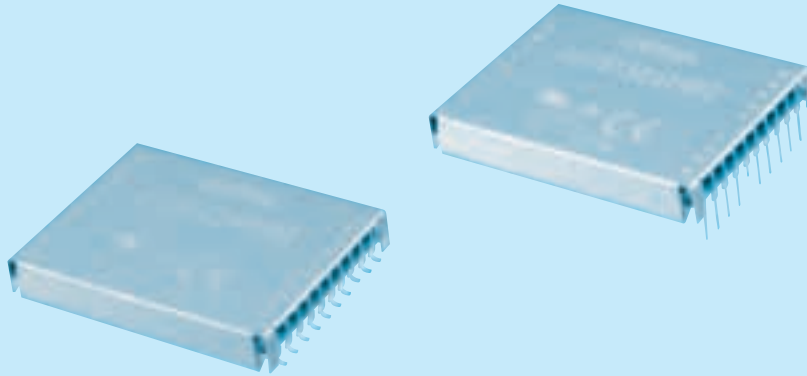

- ① Series name
- ② Single output
- ③ Output wattage
- ④ Input voltage
24:DC18 - 36V
48:DC36 - 76V
- ⑤ Output voltage
- ⑥ Mounting type
B :SMD
C :DIP

MODEL	SFCS15243R3	SFCS152405	SFCS152412	SFCS152415	SFCS15483R3	SFCS154805	SFCS154812	SFCS154815
MAX OUTPUT WATTAGE[W]	14.85	15.0	15.0	15.0	14.85	15.0	15.0	15.0
DC OUTPUT	3.3V 4.5A	5V 3A	12V 1.25A	15V 1A	3.3V 4.5A	5V 3A	12V 1.25A	15V 1A

SPECIFICATIONS

	MODEL	SFCS15243R3	SFCS152405	SFCS152412	SFCS152415	SFCS15483R3	SFCS154805	SFCS154812	SFCS154815	
INPUT	VOLTAGE[V]	DC18 - 36				DC36 - 76				
	CURRENT[A]	*1 0.7typ	0.69typ	0.7typ	0.7typ	0.35typ	0.35typ	0.35typ	0.35typ	
	EFFICIENCY[%]	*1 89typ	90typ	89typ	89typ	89typ	90typ	89typ	89typ	
	START-UP VOLTAGE[V]	DC16 - 18				DC32 - 36				
	HYSTERESIS VOLTAGE[V]	DC1 min				DC2 min				
OUTPUT	VOLTAGE[V]	3.3	5	12	15	3.3	5	12	15	
	CURRENT[A]	4.5	3	1.25	1	4.5	3	1.25	1	
	VOLTAGE ACCURACY[%]	+5, -3								
	RIPPLE[mVp-p]	25max			120max		25max		120max	
	RIPPLE NOISE[mVp-p]	50max			150max		50max		150max	
	START-UP TIME[ms]	20 - 200max (DCIN 24V, Io=100%)				20 - 200max (DCIN 48V, Io=100%)				
OUTPUT VOLTAGE SETTING *1	±1% of rated output voltage									
PROTECTION CIRCUIT AND OTHERS	OVERCURRENT PROTECTION	Works over 103% of rating								
	OVERVOLTAGE PROTECTION	Works at 120 - 140% of rating								
	LOWVOLTAGE PROTECTION	Works at 90% max of rating								
	REMOTE ON/OFF	Provided(RC open : ON, short between RC and +Vin : OFF)								
ISOLATION	INPUT-OUTPUT	DC1,000V or AC500V 1minute, Cutoff current = 100mA, DC500V 50MΩ min (20±15°C)								
	INPUT-CASE	DC500V or AC500V 1minute, Cutoff current = 10mA, DC500V 50MΩ min (20±15°C)								
	OUTPUT-CASE	DC500V or AC500V 1minute, Cutoff current = 10mA, DC500V 50MΩ min (20±15°C)								
ENVIRONMENT	OPERATING TEMP.,HUMID.AND ALTITUDE	-40 to +85°C, 20 - 95%RH (Non condensing), 3,000m (10,000feet) max								
	STORAGE TEMP.,HUMID.AND ALTITUDE	-40 to +100°C, 20 - 95%RH (Non condensing), 9,000m (30,000feet) max								
	VIBRATION	10 - 55Hz, 49.0m/s ² (5G), 3minutes period, 60minutes each along X, Y and Z axis								
	IMPACT	196.1m/s ² (20G), 11ms, once each X, Y and Z axis								
SAFETY	AGENCY APPROVALS	UL60950-1, C-UL (CSA60950-1), EN60950-1								
OTHERS	CASE SIZE/WEIGHT	39.1 × 6.8 × 29.5mm (W × H × D) /16g max								
	COOLING METHOD	Convection								

*1 At rated input(DC24V, DC48V), rated load and 25°C

External view

1.SMD(Type:B)

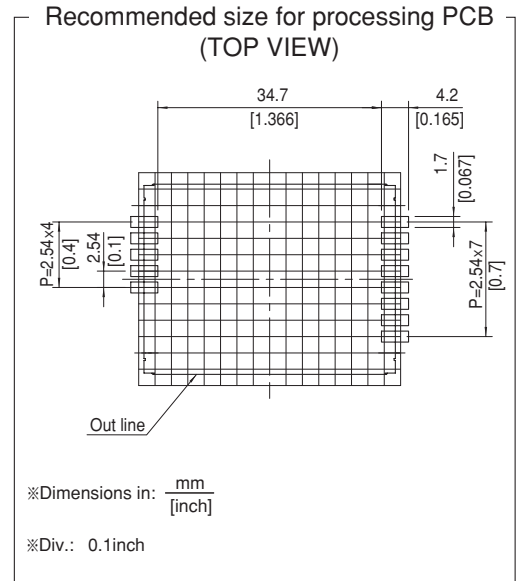
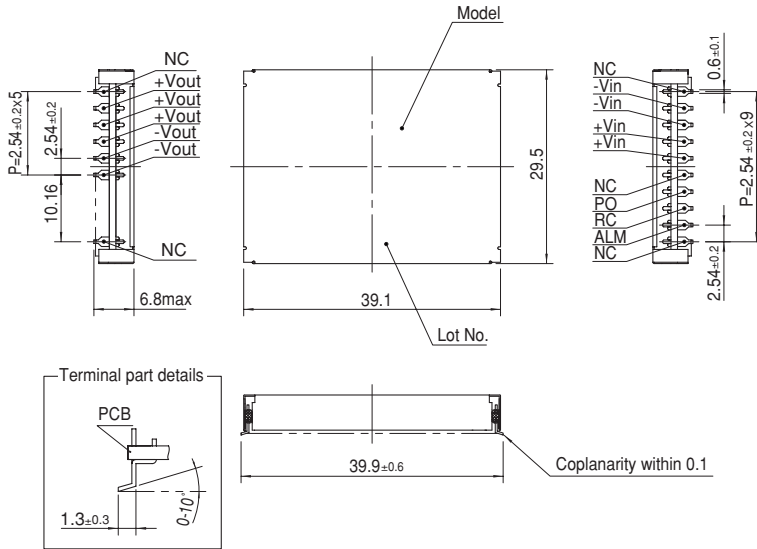

2.DIP(Type:C)

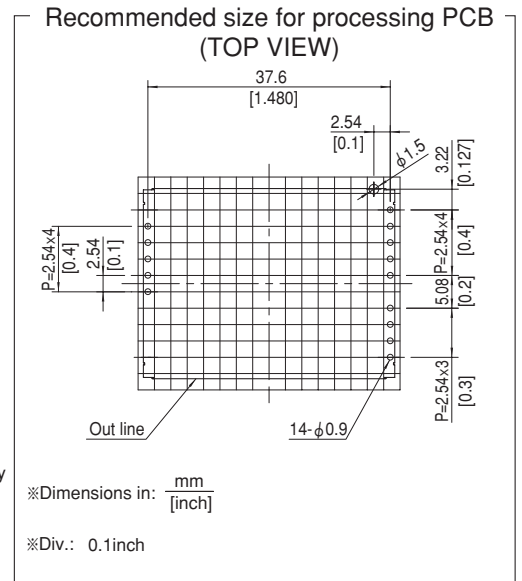
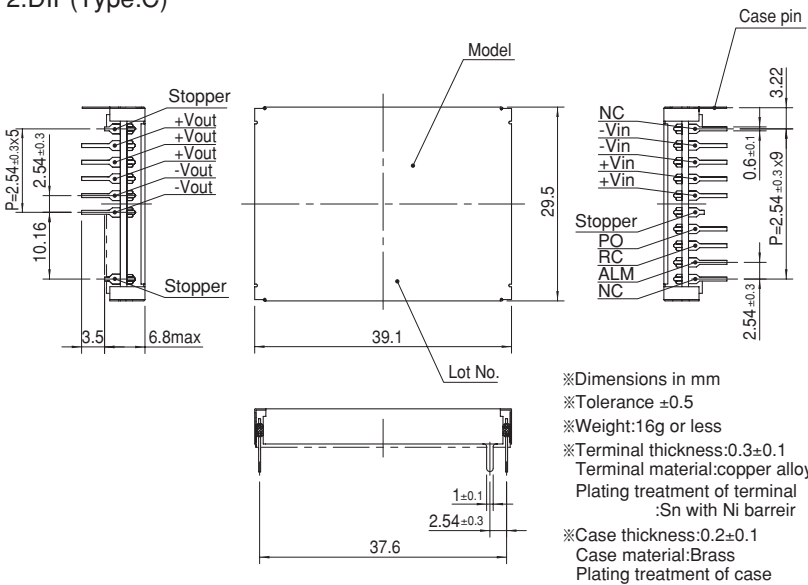

SFCS30

SFC S 30 24 3R3 C

① ② ③ ④ ⑤ ⑥

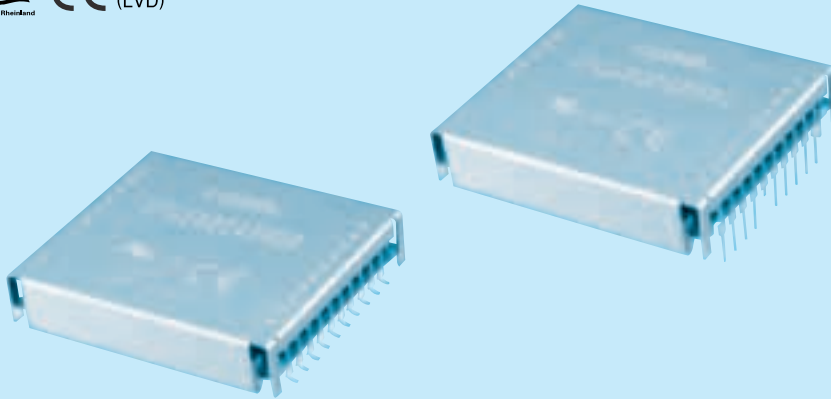

- ① Series name
- ② Single output
- ③ Output wattage
- ④ Input voltage
24:DC18 - 36V
48:DC36 - 76V
- ⑤ Output voltage
- ⑥ Mounting type
B :SMD
C :DIP

MODEL	SFCS30243R3	SFCS302405	SFCS302412	SFCS302415	SFCS30483R3	SFCS304805	SFCS304812	SFCS304815
MAX OUTPUT WATTAGE[W]	29.7	30.0	30.0	30.0	29.7	30.0	30.0	30.0
DC OUTPUT	3.3V 9A	5V 6A	12V 2.5A	15V 2A	3.3V 9A	5V 6A	12V 2.5A	15V 2A

SPECIFICATIONS

	MODEL	SFCS30243R3	SFCS302405	SFCS302412	SFCS302415	SFCS30483R3	SFCS304805	SFCS304812	SFCS304815	
INPUT	VOLTAGE[V]	DC18 - 36				DC36 - 76				
	CURRENT[A]	*1 1.36typ	1.36typ	1.36typ	1.39typ	0.67typ	0.68typ	0.68typ	0.68typ	
	EFFICIENCY[%]	*1 91typ	92typ	92typ	90typ	92typ	92.5typ	92typ	92typ	
	START-UP VOLTAGE[V]	DC16 - 18				DC32 - 36				
	HYSTERESIS VOLTAGE[V]	DC1 min				DC2 min				
OUTPUT	VOLTAGE[V]	3.3	5	12	15	3.3	5	12	15	
	CURRENT[A]	9	6	2.5	2	9	6	2.5	2	
	VOLTAGE ACCURACY[%]	+5, -3								
	RIPPLE[mVp-p]	25max			120max		25max		120max	
	RIPPLE NOISE[mVp-p]	50max			150max		50max		150max	
	START-UP TIME[ms]	20 - 200max (DCIN 24V, Io=100%)					20 - 200max (DCIN 48V, Io=100%)			
PROTECTION CIRCUIT AND OTHERS	OUTPUT VOLTAGE SETTING *1	±1% of rated output voltage								
	OVERCURRENT PROTECTION	Works over 103% of rating								
	OVERVOLTAGE PROTECTION	Works at 120 - 140% of rating								
	LOWVOLTAGE PROTECTION	Works at 90% max of rating								
	REMOTE ON/OFF	Provided(RC open : ON, short between RC and +Vin : OFF)								
ISOLATION	INPUT-OUTPUT	DC1,000V or AC500V 1minute, Cutoff current = 100mA, DC500V 50MΩ min (20±15°C)								
	INPUT-CASE	DC500V or AC500V 1minute, Cutoff current = 10mA, DC500V 50MΩ min (20±15°C)								
	OUTPUT-CASE	DC500V or AC500V 1minute, Cutoff current = 10mA, DC500V 50MΩ min (20±15°C)								
ENVIRONMENT	OPERATING TEMP.,HUMID.AND ALTITUDE	-40 to +85°C, 20 - 95%RH (Non condensing), 3,000m (10,000feet) max								
	STORAGE TEMP.,HUMID.AND ALTITUDE	-40 to +100°C, 20 - 95%RH (Non condensing), 9,000m (30,000feet) max								
	VIBRATION	10 - 55Hz, 49.0m/s ² (5G), 3minutes period, 60minutes each along X, Y and Z axis								
	IMPACT	196.1m/s ² (20G), 11ms, once each X, Y and Z axis								
SAFETY	AGENCY APPROVALS	UL60950-1, C-UL (CSA60950-1), EN60950-1								
OTHERS	CASE SIZE/WEIGHT	39.3 × 8.8 × 33.5mm (W × H × D) /25g max								
	COOLING METHOD	Convection / Forced air								

*1 At rated input(DC24V, DC48V), rated load and 25°C

External view

1.SMD(Type:B)

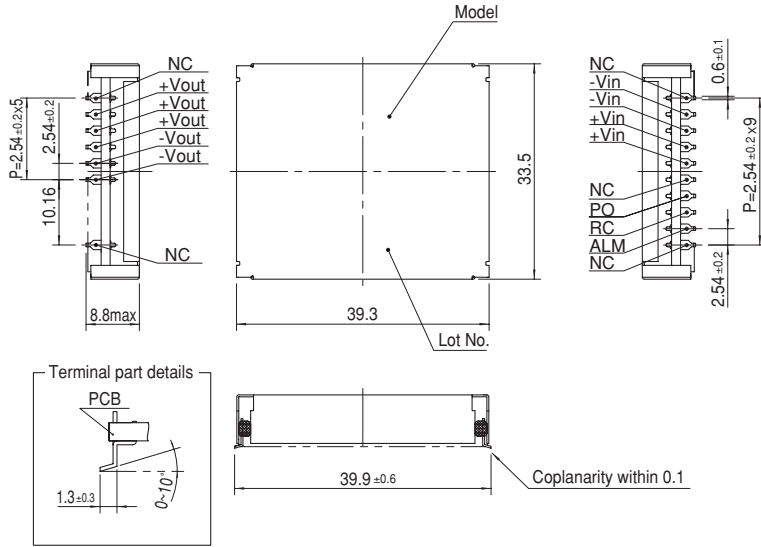

Recommended size for processing PCB (TOP VIEW)

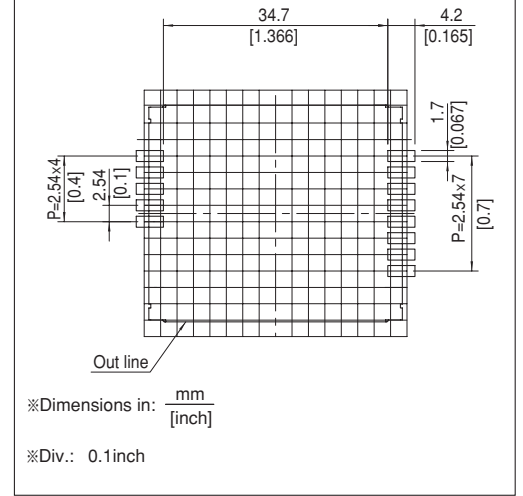

2.DIP(Type:C)

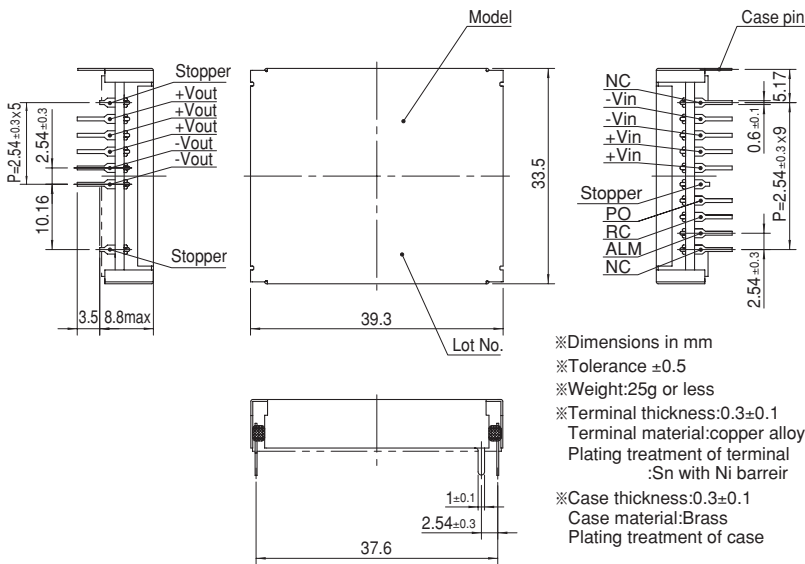

Recommended size for processing PCB (TOP VIEW)

