

Basic Characteristics Data

Model	Circuit method	Switching frequency [kHz]	Input current [A]	Rated input fuse	Inrush current protection circuit	PCB/Pattern			Series/Parallel operation availability	
						Material	Single sided	Double sided	Series operation	Parallel operation
SNDPF1000	Active filter	130	11.5 *1	250V 20A	SCR	FR-4		Yes	No	Yes *3
			8.5 *2							

*1 The value of input current is at AC100V and 1000W load.

*2 The value of input current is at AC200V and 1500W load.

*3 Refer to Instruction Manual 5 Series and Parallel Operation.

1	Terminal Connection	SNDPF-6
2	Input Voltage Derating	SNDPF-6
3	Standard Connection Method	SNDPF-6
	3.1 Standard connection method	SNDPF-6
	3.2 Connection of loaded circuit	SNDPF-7
	3.3 Heatsink	SNDPF-7
4	Function	SNDPF-7
	4.1 Overcurrent protection	SNDPF-7
	4.2 Overvoltage protection	SNDPF-7
	4.3 Thermal protection	SNDPF-7
	4.4 Enable signal (ENA)	SNDPF-7
	4.5 Inverter operation monitor (IOG)	SNDPF-8
	4.6 Auxiliary power supply circuit for external signal (AUX)	SNDPF-8
	4.7 Isolation	SNDPF-8
5	Series and Parallel Operation	SNDPF-8
	5.1 Series operation	SNDPF-8
	5.2 Parallel operation	SNDPF-8
	5.3 Synchronized start up of Several power supplies	SNDPF-9
6	Implementation · Mounting Method	SNDPF-9
	6.1 Mounting method	SNDPF-9
	6.2 Derating	SNDPF-9

1 Terminal Connection

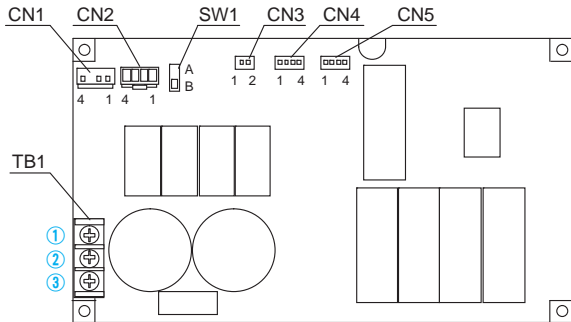

Fig.1.1 Terminal Connection

Table 1.1 Terminal connection and functions

No	Terminal connection	Function
①	AC(L)	AC Input
②	AC(N)	
③	FG	FG

Table 1.2 Terminal connection and functions of CN1

Pin No.	Function
1	ENA-B : Enable signal for SNDBS
2	-VOUT : -DC output
3	NC : No connection
4	+VOUT : +DC output

Table 1.3 Terminal connection and functions of CN2

Pin No.	Function
1	ENA-B/A : Enable signal for SNDHS
2	-VOUT : -DC output
3	NC : No connection
4	+VOUT : +DC output

Housing for protection is attached on CN2 at shipping from factory

Table 1.4 Terminal connection and functions CN3

Pin No.	Function
1	I0G : Inverter operation monitor
2	AUX : Auxiliary power supply for external signal

Table 1.5 Terminal connection and functions of CN4 and CN5

Pin No.	Function
1	C-AUX : Auxiliary power supply for external signal for synchronized start up
2	C-ENA : Enable signal for synchronized start up
3	SG : Signal ground
4	CB : Current balance

Common signs among CN4 and CN5 represent the same potential.

Table 1.6 Mating connectors and terminals of CN1,CN2,CN3,CN4 and CN5

Connector	Mating connector	Terminal	Mfr.	
CN1 CN2	B3P4-VH-B	VHR-4N	Reel :SVH-21T-P1.1 Loose:BVH-21T-P1.1	J.S.T.
CN3	B2B-XH-AM	XHP-2	Reel :SXH-001T-P0.6 Loose:BXH-001T-P0.6	
CN4 CN5	B4B-XH-AM	XHP-4	Reel :SXH-001T-P0.6 Loose:BXH-001T-P0.6	

2 Input Voltage Derating

■ Fig.2.1 shows rated output for each input voltage section. Maximum output should be within this range.

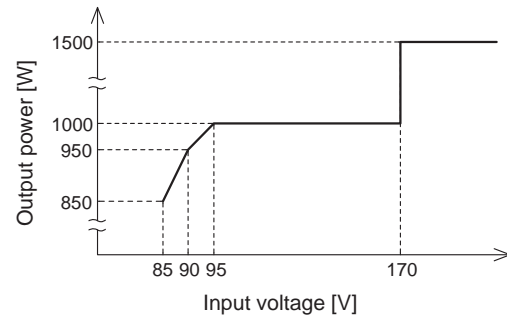

Fig.2.1 Input voltage derating curve

3 Standard Connection Method

3.1 Standard connection method

■ To use SNDPF1000, connection shown in Fig.3.1 and outside attached components are required. Through this connection, DC output voltage can be obtained from AC input voltage. AC input voltage and DC output voltage are not insulated.

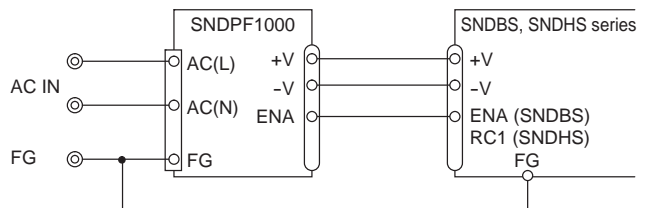

Fig.3.1 Standard connection method

3.2 Connection of loaded circuit

- Control load current so that it may flow only when the terminal ENA is at "H".
- For connecting the SNDBS/SNDHS series, see Fig.3.1.
- For connection of loads except the SNDBS/SNDHS series, please contact Cosel development department.

3.3 Heatsink

- The power supply adopts the conduction cooling system. Attach a heatsink to the aluminum base plate to cool the power supply for use.
Refer to 6.2 Derating.

4 Function

4.1 Overcurrent protection

- The overcurrent protection circuit is not built-in.
- In order to secure the safety, use the fuse at output side for connection of loads except the SNDBS/SNDHS series.

4.2 Overvoltage protection

- The overvoltage protection circuit is built-in. The AC input should be shut down if overvoltage protection is in operation. When this function operates, the power factor corrector function does not operate, and output voltage becomes the full-wave rectified AC input voltage. The minimum interval of AC recycling for recovery is a few minutes which output voltage drops below 20V.

Remarks:

Please note that the unit's internal components may be damaged if excessive voltage (over rated voltage) is applied to output terminal of power supply. This could happen when the customer tests the overvoltage performance of the unit.

4.3 Thermal protection

- Thermal protection circuit is built-in.
If this function comes into effect, shut down the output, eliminate all possible causes of overheating, and drop the temperature to normal level.
To prevent the unit from overheating, avoid using the unit in a dusty, poorly ventilated environment.
- When this function operates, the power factor corrector function does not operate, and output voltage becomes the full-wave rectified AC input voltage and ENA output changes into "L".
- When this function operates, the power factor corrector function does not operate, and output voltage becomes the full-wave rectified AC input voltage.

4.4 Enable signal (ENA)

- Use ENA to control starting of the loaded power supply.
- When inrush current protection circuit is released, ENA outputs "H".
If load current flows without releasing of the circuit, the resistor may be damaged.
- Setting of ENA has two kinds of SNDHS use (ENA-A) and the SNDBS use (ENA-B).
The setting of ENA-A is possible only in CN2.
Please connect the ENA-A terminal to RC1 terminal of the SNDHS series.

Table 4.1 Specification of ENA

No.	Item	ENA-A	ENA-B
1	Load of SNDPF1000	SNDHS series	SNDBS series
2	Signal pin	ENA-B/A at CN2	ENA-B at CN1 ENA-B/A at CN2
3	Base pin	-VOUT	
4	Setting of SW1	A	B
5	Function	Output possible "H"	
		Output prohibited "L"	
6	Level voltage "H"	5.5V typ at 1mA	7.5V typ at 1mA
7	Level voltage "L"	Open collector	

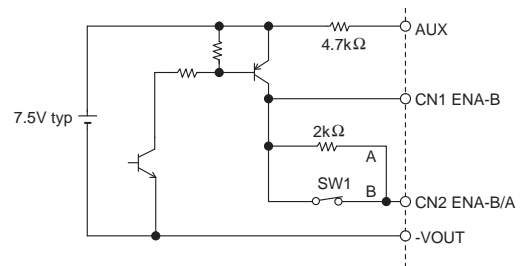
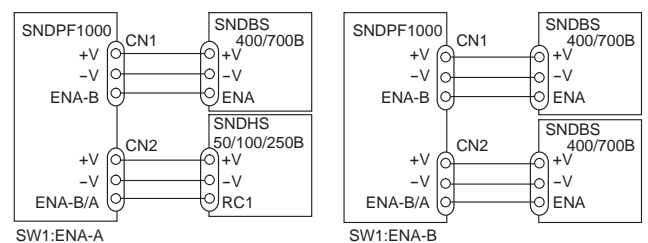

Fig.4.1 Internal circuit of ENA



(a) Example of connection to ENA using SNDHS

(b) Example of connection to ENA using SNDBS

Fig.4.2 Example of connection to ENA

4.5 Inverter operation monitor (IOG)

■ Use IOG to monitor operation of the inverter.

When unit operation stopped due to overvoltage protection, thermal protection or the event of a failure in the power supply, IOG-signal state changes to "H" from "L" within 1 second.

And output voltage becomes an equal value to the full-wave rectified AC input voltage.

If IOG signal status keeps "H", there is a possibility that unit and/or external circuit is damaged. In case like this, please check the unit and/or external circuit conditions in your system.

IOG can be used for monitoring failures such as redundant operation.

■ IOG may become unstable in case of start-up or sudden change of load current. Set the timer with delay of more than 5 seconds.

■ During parallel operation, unstable condition may occur when load current becomes lower than 10% of rated value.

Table 4.2 Specification of IOG

No.	Item	IOG
1	Function	L Normal operation
		H Malfunction of inverter
2	Output level	L 0.6Vmax at 10mA 10mA max
		H Open collector 35V max
3	Base pin	-VOUT

4.6 Auxiliary power supply circuit for external signal (AUX)

■ The AUX pin can be used as the power source with the open collector output for IOG .

■ Shortprotection resistance (4.7kΩ) is built in.

Output voltage decreases as the output current increases.

4.7 Isolation

■ For a receiving inspection, such as Hi-Pot test, gradually increase (decrease) the voltage for a start(shut down). Avoid using Hi-Pot tester with the timer because it may generate voltage a few times higher than the applied voltage, at ON/OFF of a timer.

5 Series and Parallel Operation

5.1 Series operation

■ As input and output are not insulated, series operation is impossible.

5.2 Parallel operation

■ Parallel operation is available by connecting the units as shown in Fig.5.1.

Synchronization output current balance, ENA signal is performed.

■ As variance of output current drew from each power supply is maximum 10%, the total output current must not exceed the value determined by the following equation.

$$\left(\begin{array}{l} \text{Output current in} \\ \text{parallel operation} \end{array} \right) = \left(\begin{array}{l} \text{the rated current} \\ \text{per unit} \end{array} \right) \times (\text{number of unit}) \times 0.9$$

In parallel operation, the maximum operative number of units is 5.

■ When the output-line impedance is high, the power supply is become unstable. Use same length and thickness (width) wire (pattern) for the current balance improvement.

■ Connect each input pin for the lowest possible impedance.

When the number of the units in parallel operation increases, input current increases.

Adequate wiring design for input circuitry such as circuit pattern, wiring and current for equipment is required.

If temperatures of aluminum base plates are different in the power supply for parallel operation, values of output current will change greatly.

Design radiation to equalize plate temperatures by attaching the same heatsinks.

■ Fuse, each diode to the output terminal of each power supply in order to ensure safety Please connect.

The output side diode if the following three parallel units are omitted Can be.

■ Input voltage of the power supply to operate in parallel, please supply the same strain.

■ Keep drawing current per pin below 7A for CN1/CN2.

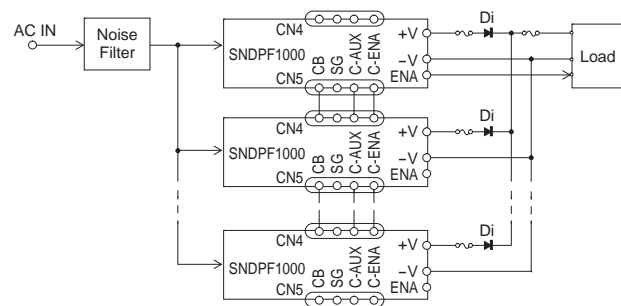

* Common signs among CN4 and CN5 represent the same potential.
* Please connect each CB, C-AUX and C-ENA.

Fig.5.1 Parallel operation

5.3 Synchronized start up of Several power supplies

- Make a connection in Figure 5.2, ENA signal to be synchronized, even if you do not parallel operation is possible. When all SNDFPF1000 connected becomes able to work, ENA signal turns into H.
- When one of the SNDFPF1000 connected is prohibited, ENA signal turns into L.
- For parallel operation and shall not, eliminating the output side diode, a fuse.

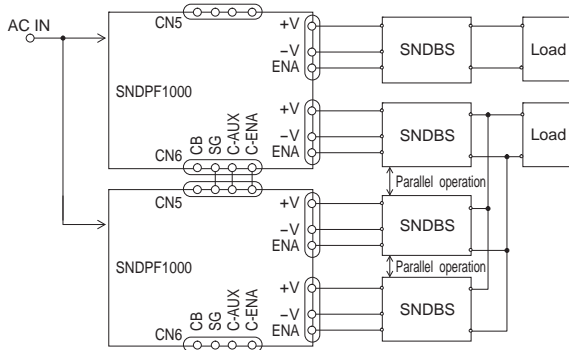

Fig.5.2 Synchronized start up connection Example

6 Implementation · Mounting Method

6.1 Mounting method

- The unit can be mounted in any direction. When two or more power supplies are used side by side, position them with proper intervals to allow enough air ventilation. Aluminum base plate temperature around each power supply should not exceed the temperature range shown in derating curve.
- In case of metal chassis, keep the distance between d_1 for to insulate between lead of component and metal chassis. If it is less than d_1 , insert the insulation sheet between power supply and metal chassis.

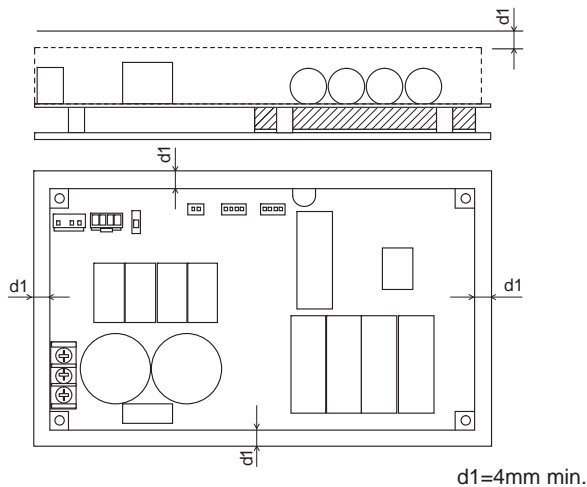

Fig.6.1 Mounting method

6.2 Derating

- Use with the conduction cooling (e.g. heat radiation by conduction from the aluminum plate to the attached heat sink). Fig.6.2 shows the derating curve based on the aluminum base plate temperature.
- Please measure the temperature on the aluminum base plate edge side (Point A). Please consider the ventilation to keep the component temperature on the PCB (Point B) less than the temperature of Fig.6.3.
- It is necessary to note the thermal fatigue life by power cycle. Please reduce the temperature fluctuation range as much as possible when the up and down of the temperature are frequently generated. Contact us for more information on cooling methods.

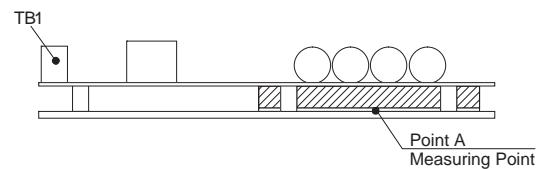
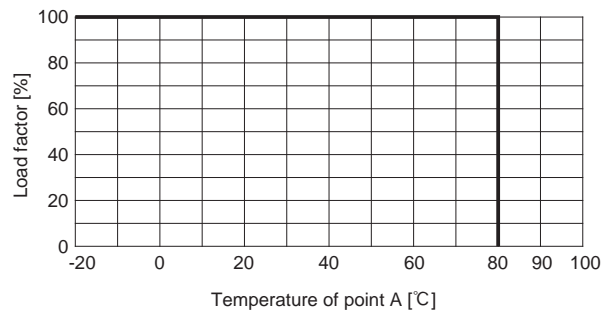

Fig.6.2 Derating curve of point A

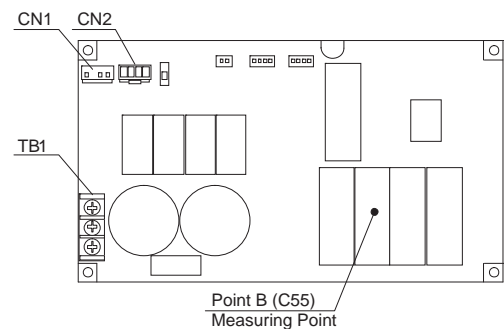
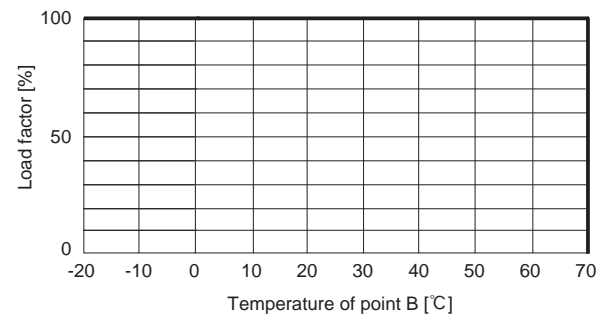

Fig.6.3 Derating curve of point B