

Basic Characteristics Data

Model	Circuit method	Switching frequency [kHz] (reference)	Input current [A]	Inrush current protection	PCB/Pattern			Series/Parallel operation	
					Material	Single sided	Double sided	Series operation	Parallel operation
BRFS30	Buck Converter	300	*1	-	glass fabric base,epoxy resin	-	Multilayer	-	*3
BRFS40	Buck Converter	300	*1	-	glass fabric base,epoxy resin	-	Multilayer	-	*3
BRFS50	Buck Converter	300 *2	*1	-	glass fabric base,epoxy resin	-	Multilayer	-	*3
BRFS50L	Buck Converter	300 *2	*1	-	glass fabric base,epoxy resin	-	Multilayer	-	*3
BRFS60	Buck Converter	300 *2	*1	-	glass fabric base,epoxy resin	-	Multilayer	-	*3
BRFS100	Buck Converter	300 *2	*1	-	glass fabric base,epoxy resin	-	Multilayer	-	*3
BRDS40	Buck Converter	300	*1	-	glass fabric base,epoxy resin	-	Multilayer	-	*3
BRDS60	Buck Converter	300 *2	*1	-	glass fabric base,epoxy resin	-	Multilayer	-	*3
BRDS100	Buck Converter	300 *2	*1	-	glass fabric base,epoxy resin	-	Multilayer	-	*3

*1 Refer to Specification.

*2 These models have 2 Phase Interleaving inverters, the frequency of ripple is 600kHz.

*3 Refer to the Instruction Manual.

1	Pin Configuration	BRFS/BRDS-12
2	Connection for Standard Use	BRFS/BRDS-13
3	Wiring Input / Output Pin	BRFS/BRDS-13
3.1	Wiring input pin	BRFS/BRDS-13
3.2	Wiring output pin	BRFS/BRDS-14
4	Function	BRFS/BRDS-14
4.1	Overcurrent protection	BRFS/BRDS-14
4.2	Thermal protection	BRFS/BRDS-14
4.3	Remote ON / OFF	BRFS/BRDS-14
4.4	Remote sensing	BRFS/BRDS-15
4.5	Adjustable voltage range	BRFS/BRDS-15
4.6	Softstart/Start-up sequence	BRFS/BRDS-15
4.7	Power good	BRFS/BRDS-16
4.8	Sequence	BRFS/BRDS-16
4.9	PMBus communication	BRFS/BRDS-16
5	Series and Parallel Operation	BRFS/BRDS-17
5.1	Series operation	BRFS/BRDS-17
5.2	Parallel operation	BRFS/BRDS-17
6	Implementation · Mounting Method	BRFS/BRDS-17
6.1	Mounting method	BRFS/BRDS-17
6.2	Automatic mounting	BRFS/BRDS-17
6.3	Soldering	BRFS/BRDS-17
6.4	Cleaning	BRFS/BRDS-18
6.5	Storage method	BRFS/BRDS-18
7	Safety Considerations	BRFS/BRDS-18
8	Derating	BRFS/BRDS-18
8.1	BRFS/BRDS series Derating	BRFS/BRDS-18
9	Package Information	BRFS/BRDS-19

1 Pin Configuration

Table 1.1 Pin connection and function of BRFS30/40

Pin No.	Pin Connection	Function
①	RC	Remote ON/OFF
②	+VIN	+DC input
③	SEQ	Control of Start up time and turn
④	GND	GND (-DC input, -DC output)
⑤	+VOUT	+DC output
⑥	TRM	Adjustment of output voltage
⑦	+S	+Remote sensing
⑧	GND	GND (-DC input, -DC output)
⑨	NC(PGOOD/ SHARE)	NC (optional : Power good (BRFS30/40), SHARE (BRFS40))
⑩	SGND	Signal GND

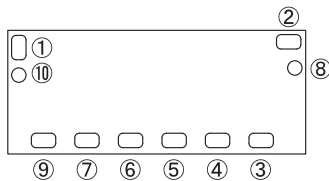
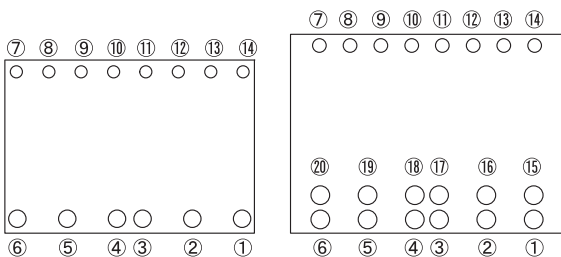

Fig.1.1 Pin connection of BRFS30/40 (BOTTOM VIEW)

Table 1.2 Pin connection and function of BRFS50/50L/60/100

Pin No.	Pin Connection	Function
① ⑮	+VIN	+DC input
② ⑯	GND	GND (-DC input, -DC output)
③ ⑰	+VOUT	+DC output
④ ⑱	+VOUT	+DC output
⑤ ⑲	GND	GND (-DC input, -DC output)
⑥ ⑳	+VIN	+DC input
⑦	SEQ	Control of Start up time and turn
⑧	PGOOD	Power good
⑨	RC	Remote ON/OFF
⑩	-S	-Remote sensing
⑪	+S	+Remote sensing
⑫	+TRM	+Adjustment of output voltage
⑬	-TRM	-Adjustment of output voltage
⑭	SHARE	Parallel operation



(a) BRFS50/50L/60

(b) BRFS100

Fig.1.2 Pin connection of BRFS50/50L/60/100 (BOTTOM VIEW)

Table 1.3 Pin connection and function of BRDS40

Pin No.	Pin Connection	Function
①	RC	Remote ON/OFF
②	+VIN	+DC input
③	SEQ	Control of Start up time and turn
④	GND	GND (-DC input, -DC output)
⑤	+VOUT	+DC output
⑥	TRM	Adjustment of output voltage
⑦	+S	+Remote sensing
⑧	GND	GND (-DC input, -DC output)
⑨	SHARE	Parallel operation
⑩	SGND	Signal GND
⑪	SGND	Signal GND
⑫	-S	-Remote sensing
⑬	CLK	PMBus communication clock input
⑭	DATA	PMBus communication data input & output
⑮	NC	NC
⑯	PGOOD	Power good
⑰	SMBALERT	PMBus alarm output
⑱	ADDR0	Address setting
⑲	ADDR1	Address setting

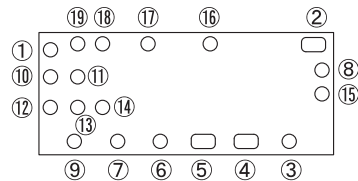
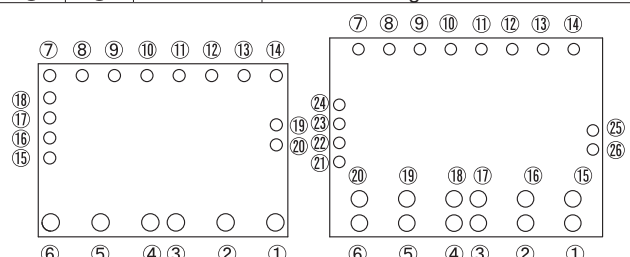

Fig.1.3 Pin connection of BRDS40 (BOTTOM VIEW)

Table 1.4 Pin connection and function of BRDS60/100

Pin No.		Pin Connection	Function
BRDS60 ①	BRDS100 ① ⑮	+VIN	+DC input
②	② ⑯	GND	GND (-DC input, -DC output)
③	③ ⑰	+VOUT	+DC output
④	④ ⑱	+VOUT	+DC output
⑤	⑤ ⑲	GND	GND (-DC input, -DC output)
⑥	⑥ ⑳	+VIN	+DC input
⑦	⑦	SEQ	Control of Start up time and turn
⑧	⑧	PGOOD	Power good
⑨	⑨	RC	Remote ON/OFF
⑩	⑩	-S	-Remote sensing
⑪	⑪	+S	+Remote sensing
⑫	⑫	+TRM	+Adjustment of output voltage
⑬	⑬	-TRM	-Adjustment of output voltage
⑭	⑭	SHARE	Parallel operation
⑮	⑳	SMBALERT	PMBus alarm output
⑯	㉑	DATA	PMBus communication data input & output
⑰	㉒	SGND	Signal GND
⑱	㉓	CLK	PMBus communication clock input
⑲	㉔	ADDR0	Address setting
⑳	㉕	ADDR1	Address setting



(a) BRDS60

(b) BRDS100

Fig.1.4 Pin connection of BRDS60/100 (BOTTOM VIEW)

2 Connection for Standard Use

■ In order to use power supply, it is necessary to wire as shown in Fig.2.1 and Fig.2.2.

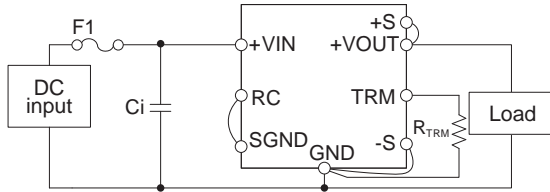

*SGND is connected to GND inside the power supply.
*Short the -S and GND only BRDS40.

Fig.2.1 Connection for standard use of BRFS30/40 · BRDS40

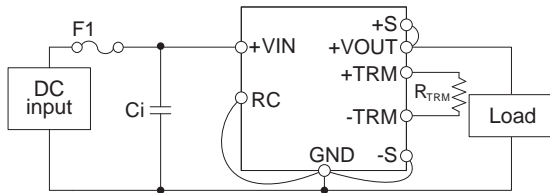

Fig.2.2 Connection for standard use of BRFS50/50L/60/100 · BRDS60/100

Reference	3	"Wiring Input/Output Pin"
	8	"Derating"

■ Short the following pins to turn on the power supply.

● **BRFS30/40**

SGND↔RC, +VOUT↔+S

● **BRFS50/50L/60/100 · BRDS40/60/100**

GND↔RC (SGND↔RC of BRDS40), +VOUT↔+S, GND↔-S

Reference	4.3	"Remote ON/OFF"
	4.4	"Remote sensing"

■ Connect resistance to set the output voltage as below.

● **BRFS30/40 · BRDS40**

GND↔TRM

● **BRFS50/50L/60/100 · BRDS60/100**

+TRM↔-TRM

Reference	4.5	"Adjustable voltage range"
-----------	-----	----------------------------

■ Between input and output is not isolated .

■ The BRFS/BRDS series handle only the DC input.

Avoid applying AC input directly.

It will damaged the power supply.

Table 2.1 External parts

No.	Parts	Reference
1	F1:Fuse	3.1(1) External fuse
2	Ci:External output capacitor	3.1(2) External input capacitor
3	R _{TRM} :Resistance for adjustment output voltage	4.4 Adjustable voltage range

3 Wiring Input/Output Pin

3.1 Wiring input pin

(1) External fuse

■ Fuse is not built-in on input side. In order to protect the unit, install the normal-blow type fuse on input side.

Table 3.1 Recommended fuse (normal-blow type)

Model	BRFS30/40 · BRDS40	BRFS50/50L	BRFS60 · BRDS60	BRFS100 · BRDS100
Rated current	40A	40A	60A	80A

■ When the input voltage from a front end unit is supplied to multiple units, install the normal-blow type fuse in each unit.

■ When the fuse is open, power good signal is not outputted.

(2) External capacitor on the input side

■ Install an external capacitor C_{in}, between +VIN and GND input pins for low line-noise and for stable operation of the power supply.

BRFS/BRDS

Table3.2 Recommended external input capacitor(Ceramic)

Model	Recommended C _i	
	V _{in} =5V	V _{in} =12V
BRFS30/40 · BRDS40	8x22 μ F	4x22 μ F
BRFS50/50L	8x22 μ F	4x22 μ F
BRFS60 · BRDS60	8x22 μ F	4x22 μ F
BRFS100 · BRDS100	8x22 μ F	4x22 μ F

■ C_{in} is within 5mm for pins. Make sure that ripple current of C_{in} is less than its rating.

■ When an impedance and inductance level of the input line become higher, the input voltage may become unstable. In that case, the input voltage becomes stable by increasing C_{in}.

(3) Recommendation for noise-filter

■ Install an external input filter as shown in Fig.3.1 in order to reduce conducted noise. C_{in} is shown in Table 3.2.

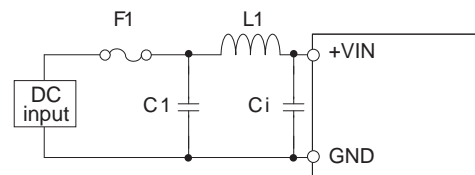

C1 :220 μ F(BRFS30/50/50L)

:470 μ F(BRFS40/60/100 · BRDS40/60/100)

L1 :0.3 μ H

Fig.3.1 Example of recommended external input filter

(4) Reverse input voltage protection

■ Avoid the reverse polarity input voltage. It will damage the power supply.

It is possible to protect the unit from the reverse input voltage by installing an external diode as shown in Fig.3.2.

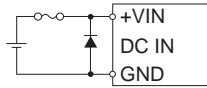

Fig.3.2 Reverse input voltage protection

3.2 Wiring output pin

■ When the BRFS/BRDS series supplies the pulse current for the pulse load, please install a capacitor C_o between +VOUT and GND pins.

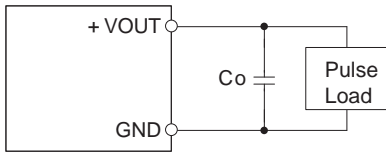

Fig.3.3 wiring external output capacitor

Table 3.3 Recommended Capacitor and max C_o

Model	Recommended C_o	MAX C_o
BRFS30/40 · BRDS40	$3 \times 100 \mu F$	$10,000 \mu F$
BRFS50/50L	$2 \times 100 \mu F$	$10,000 \mu F$
BRFS60 · BRDS60	$2 \times 100 \mu F$	$10,000 \mu F$
BRFS100 · BRDS100	$4 \times 100 \mu F$	$20,000 \mu F$

■ The output ripple voltage may grow big by resonance with C_o and ESL of the wiring, if resonance frequency and switching frequency are close.

■ Ripple and Ripple Noise are measured, as shown in the Fig.3.4. C_o0 , C_o1 , C_o2 and C_o3 is shown in Table 3.4.

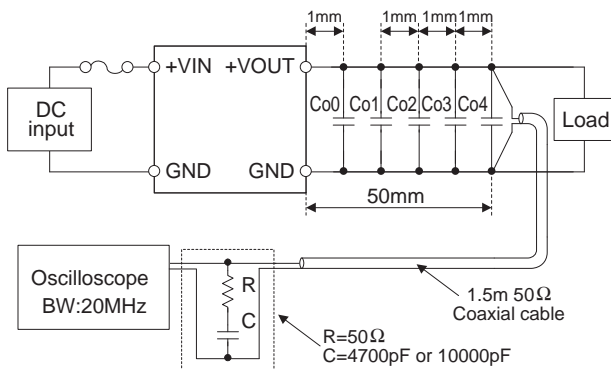

Fig.3.4 Measuring method of Ripple and Ripple Noise

Table 3.4 C_o0 , C_o1 , C_o2 and C_o3 which is used in measuring

No.	Model	C_o0	C_o1	C_o2	C_o3	C_o4
1	BRFS30	-	-	$100 \mu F$	$100 \mu F$	$100 \mu F$
2	BRFS40 · BRDS40	$100 \mu F$	-	$100 \mu F$	$100 \mu F$	$100 \mu F$
3	BRFS50/50L/60 · BRDS60	-	-	-	$100 \mu F$	$100 \mu F$
4	BRFS100 · BRDS100	-	$100 \mu F$	$100 \mu F$	$100 \mu F$	$100 \mu F$

4 Function

4.1 Overcurrent protection

■ Over Current Protection (OCP) is built-in and works at 105% of the rated current or higher. However, use in an overcurrent situation must be avoided whenever possible.

The output voltage of the power module will recover automatically when the fault causing overcurrent is corrected.

When the output voltage drops after OCP works, the power module enters a "hiccup mode" where it repeatedly turns on and off at a certain frequency.

4.2 Thermal protection

■ When the power supply temperature is kept above $120^\circ C$, the thermal protection will be activated and simultaneously shut down the output.

The output voltage of the power supply will recover automatically when the unit is cool down.

4.3 Remote ON/OFF

■ The remote ON/OFF function is incorporated in the input circuit and operated with RC and GND. If positive logic control is required, order the power supply with "-R" option.

Table4.1 Specification of Remote ON/OFF

	ON/OFF logic	Between RC and GND	Output voltage
Standard	Negative	L level(-0.2 - 0.6V) or short	ON
		H level(3.0 - VIN) or open	OFF
Optional -R	Positive	L level(-0.2 - 0.6V) or short	OFF
		H level(3.0 - VIN) or open	ON

*Source current from RC pin is 0.5mA(max).

■ When remote on/off function is not used, please short GND and RC.

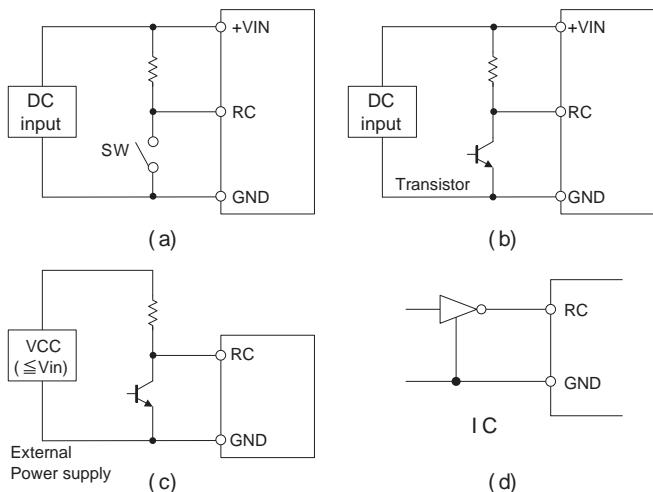

Fig.4.1 RC connection example

4.4 Remote sensing

(1) When the remote sensing function is not in use

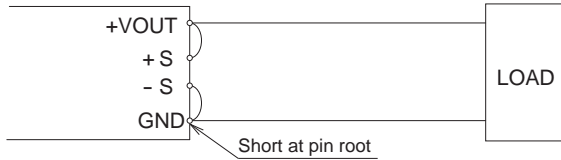

Fig.4.2 Connection when the remort sensing is not in use

- When the remote sensing function is not in use, it is necessary to confirm that pins are shorted between +S & +VOUT and between -S & GND.
- Wire between +S & +VOUT and between -S & GND as short as possible. Loop wiring should be avoided. This power supply might become unstable by the noise coming from poor wiring.

(2) When the remote sensing function is in use

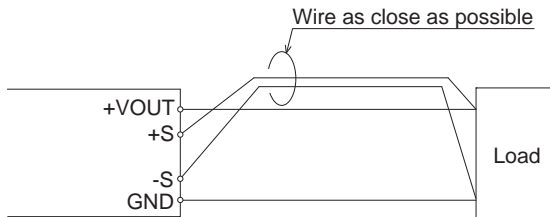

Fig.4.3 Connection when the remote sensing is in use

- Twisted-pair wire or shield wire should be used for sensing wire.
- Thick wire should be used for wiring between the power supply and a load. Line drop should be less than 0.5V. Voltage between +VOUT and GND should remain within the output voltage adjustment range.
- If the sensing patterns are short, heavy-current is drawn and the pattern may be damaged. The pattern disconnection can be prevented by installing the protection parts as close as a load.

4.5 Adjustable voltage range

- Output voltage is adjustable by the external resistor.
- The temperature cofficiect could become worse, depending on the type of a resistor. Resistor.....Metal film type, coefficient of less than ±100ppm/°C
- When TRM is opened, output voltage is adjusted to the minimum.
- R_{TRM} is calculated in the following expressions.

$$R_{TRM} = \frac{8}{V_{OUT}-0.8} [k\Omega] \quad R_{TRM} = \frac{12}{V_{OUT}-0.6} [k\Omega] \quad R_{TRM} = \frac{14}{V_{OUT}-0.7} [k\Omega]$$

BRFS30 BRFS40 · BRDS40 BRFS50/50L/60/100 · BRDS60/100

Table 4.2 Calculation result of BRFS30

No	VOUT	R _{TRM}
1	0.8	OPEN
2	1.0	40.0kΩ
3	1.2	20.0kΩ
4	1.5	11.429kΩ
5	1.8	8.0kΩ
6	2.5	4.706kΩ
7	3.3	3.2kΩ

Table 4.3 Calculation result of BRFS40 · BRDS40

No	VOUT	R _{TRM}
1	0.6	OPEN
2	1.0	30.0kΩ
3	1.2	20.0kΩ
4	1.5	13.3kΩ
5	1.8	10.0kΩ

Table 4.4 Calculation result of BRFS50/50L/60/100 · BRDS60/100

No	VOUT	R _{TRM}
1	0.7	OPEN
2	1.0	46.6kΩ
3	1.2	28.0kΩ
4	1.5	17.5kΩ
5	1.8	12.7kΩ

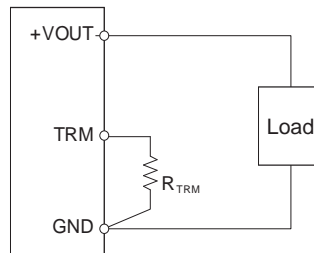

Fig.4.4 Connecting BRFS30/40 · BRDS40

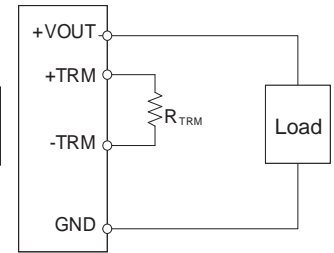

Fig.4.5 Connecting BRFS50/50L/60/100 · BRDS60/100

4.6 Softstart/Start-up sequence

- The adjustment of the rise time is possible by connecting C_{SEQ}.

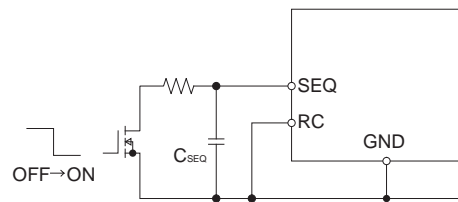

Fig.4.6 Example of soft start circuit

- When the voltage is applied to the terminal SEQ, the output voltage tracks this voltage until the output reaches the set-point voltage. SEQ terminal voltage vs output voltage is calculated the following formula. Avoid SEQ terminal voltage is set below the set voltage output by R_{trm}, the output voltage does not rise to set output voltage. Maximum applicable voltage of terminal SEQ is V_{in}.When the function is not used, open terminal SEQ.

$$C_{SEQ} [\mu F] = (0.284 \div V_o[V] - 0.06) \times T[ms] \quad (0.6V \leq V_o \leq 2.0V)$$

$$C_{SEQ} [\mu F] = (0.284 \div V_o[V] - 0.047) \times T[ms] \quad (2.0V < V_o \leq 3.63V \text{ only BRFS30})$$

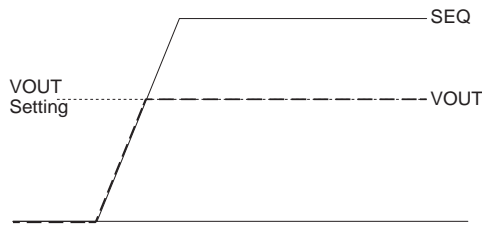

Fig.4.7 SEQ > Vout setting

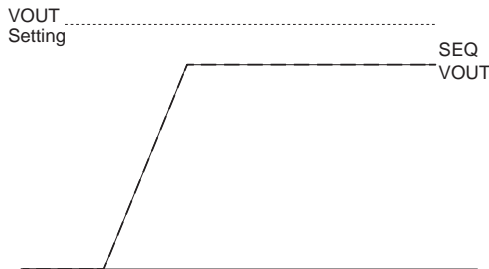
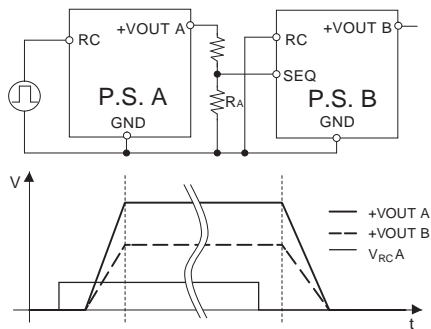

Fig.4.8 SEQ < Vout setting (not recommended)

With the voltage to input into SEQ pin, you can control a start sequence of plural power supplies.

(a) The same time



(b) The same voltage

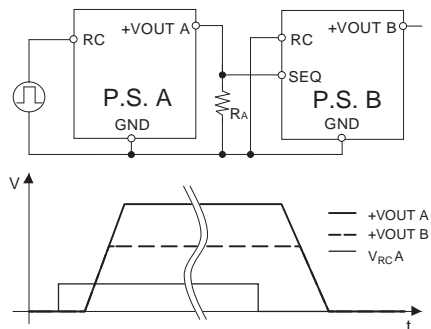

(c) The time lag

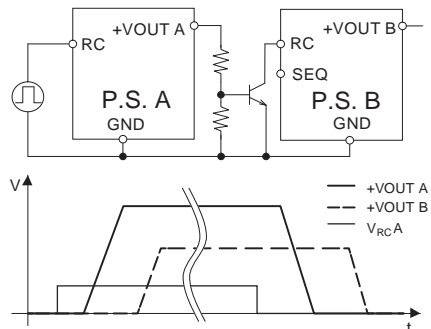

Fig.4.9 Example of sequence control

- If this function is unnecessary, please make SEQ pin open.
- It is not possible to shorten the rise time when not using this function.

4.7 Power good

- By using PGOOD, it is possible to monitor power supply whether normal operation or abnormal operation.
- PGOOD circuit is designed as shown in Fig.4.10.
- Sink current of PGOOD is 10mA max.

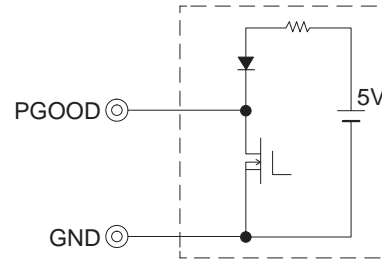

Fig.4.10 Internal PGOOD circuit

- Voltage of PGOOD pin become low when over current protection circuit is work, or output voltage is different from a set point more than ±12.5%.
- If this function is unnecessary, please make PGOOD pin open.

4.8 Sequence

Fig.4.11 is a sequence chart of each function of BRFS/BRDS.

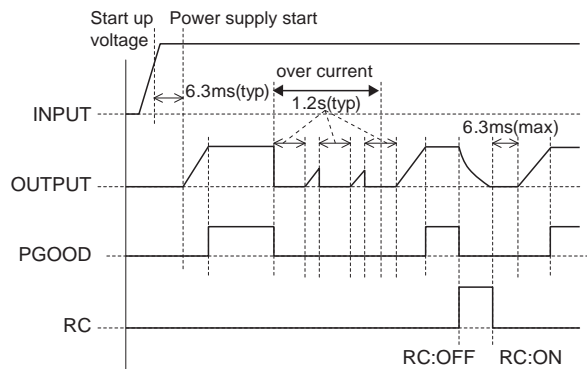

Fig.4.11 Sequence chart of BRFS/BRDS

4.9 PMBus communication

- PMBus communication is possible BRDS series.
- For more information please contact us.

5 Series and Parallel Operation

5.1 Series operation

■Series operation is not possible.

5.2 Parallel operation

- Parallel operation is possible BRFS50/50L/60/100 · BRDS series (BRFS30/40 is not possible). BRFS40 has a parallel operation "P".
- In parallel operation, wiring as Fig.5.1
- Make the +S and -S of the slave power supply unconnected.
- To improve the load sharing of each unit, use the same length and same wire size from each unit to the load.
- As variance of output current drew from each power supply is maximum 10%, the total output current must not exceed the value determined by the following equation.

(Output current at parallel operation)

$$= (\text{the rated current per unit}) \times (\text{number of unit}) \times 0.9$$

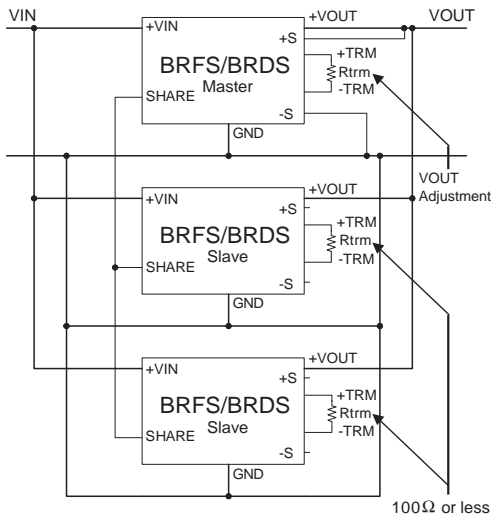

Fig.5.1 Example of wiring method in parallel operation

- Make power supply from the same input power supply.
- Total number of units should be no more than 5 pieces.
- PGOOD of slave power supply output the operating conditions. When power supply is in operation, PGOOD output high level. At the time of stop, it output low level.
- Please connect each other's SEQ pins if you use SEQ pin.
- Voltage drop from a power supply to the sensing point should be less than 0.2V for stable control.
- Only use RC pin of the master power supply, RC pin of the slave power supply should be short to GND. Or let RC pin's of the master power supply and the slave power supply short, and please use it.
- If this function is unnecessary, please make SHARE pin open.
- In parallel operation, please use a single model together. When it is necessary to use different model together, please contact us.
- In the case of stop using the SEQ function in parallel operation, the power supply will immediately stop when SEQ terminal voltage is below the output voltage set by the R_{TRM}.

6 Implementation · Mounting Method

6.1 Mounting method

■The unit can be mounted in any direction. When two or more power supplies are used side by side, position them with proper intervals to allow enough air ventilation. The temperature around each power supply should not exceed the temperature range shown in derating curve.

6.2 Automatic Mounting

■To mount BRFS/BRDS series automatically, use the coil area near the center of the PCB as an adsorption point. Please see the External View for details of the adsorption point.

6.3 Soldering

■Fig.6.1 shows condition for reflow of BRFS/BRDS series. Please make sure that the temperature of pin shown in Fig.6.2 do not exceed the temperatures shown in Fig.6.1.

■While soldering, having vibration or impact on the unit should be avoided, because of solder melting.

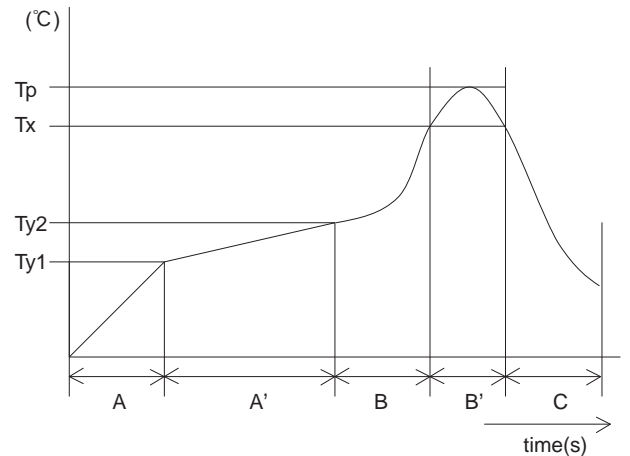

A	1.0 - 5.0°C/ s
A'	Ty1 : 160±10°C Ty2 : 180±10°C Ty1 - Ty2 : 120s max
B	1.0 - 5.0°C/ s
B'	Tp : Max245°C 10s max Tx : 220°C or more : 70s max
C	1.0 - 5.0°C/ s

Fig.6.1 Recommended reflow soldering condition

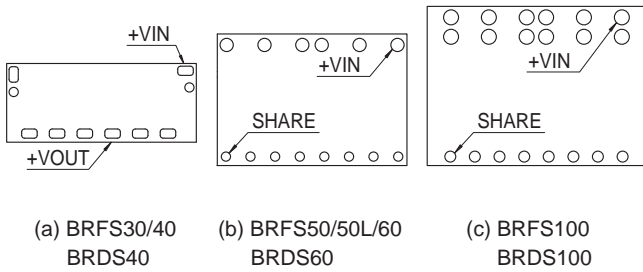

Fig.6.2 Measurement point of temperature

- Please do not do the implementation except the reflow.
- Because some parts drops, please do not do reflow of the back side.

6.4 Cleaning

- When cleaning is necessary, clean under the following conditions.
 - Method : Varnishing, ultrasonic wave and vapor
 - Cleaning agents : IPA (Solvent type)
 - Total time : 2 minutes or less
- Do not apply pressure to the lead and name plate with a brush or scratch it during the cleaning.
- After cleaning, dry them enough.

6.5 Storage method

- To stock unpacked products in your inventory, it is recommended to keep them under controlled condition, 5-30°C, 60%RH and use them within a year.
- 24-hour baking is recommended at 125°C, if unpacked products were kept under uncontrolled condition, which is 30°C, 60%RH or higher.
 - Original reels are not heat-resistant. Please move them to heat-resistant trays in preparation to bake.
 - To check moisture condition in the pack, silica gel packet has some moisture condition indicator particles.
 - Indicated blue means good. Pink means alarm to bake it.
- The reels will be deformed and the power supply might be damaged, if the vacuum pressure is too much to reseal.

7 Safety Considerations

- To apply for safety standard approval using this power supply, the following conditions must be met.
 - This unit must be used as a component of the end-use equipment.
 - Safety approved fuse must be externally installed on input side.

8 Derating

8.1 BRFS/BRDS series Derating

- Make sure the temperatures measurement locations shown from Fig.8.2 to Fig.8.6 below are on or under the derating curve in Fig.8.1.
 - Ambient temperature must be kept at 85°C or under.

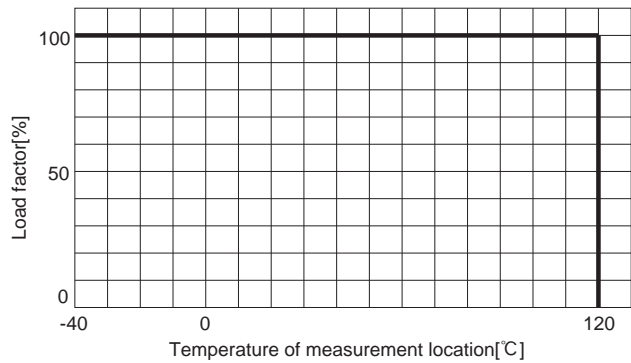

Fig.8.1 Derating curve

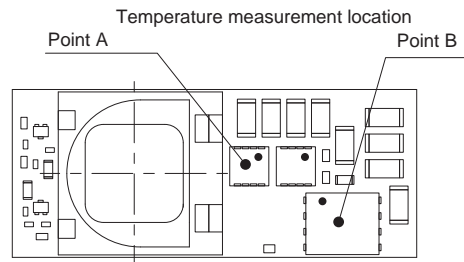

Fig.8.2 Temperature measurement location (BRFS30)

9 Package Information

- Please refer to a Fig.9.1 to Fig.9.4 for Package form (Reel).
- The packed number is 200 (BRFS30/40 · BRDS40), 100 (BRFS50/50L/60 · BRDS60), 80 (BRFS100 · BRDS100).

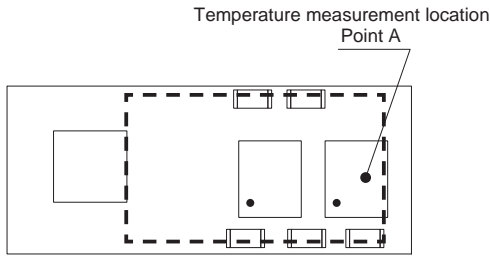

Fig.8.3 Temperature measurement location (BRFS40 · BRDS40)

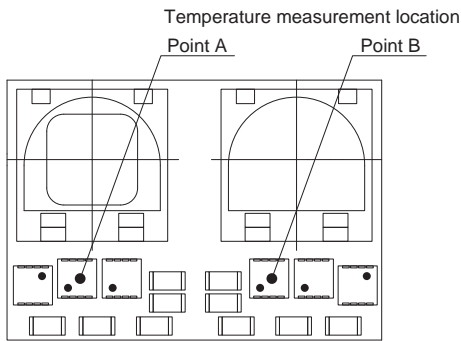

Fig.8.4 Temperature measurement location (BRFS50/50L)

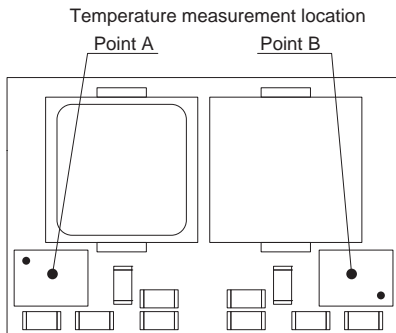

Fig.8.5 Temperature measurement location (BRFS60 · BRDS60)

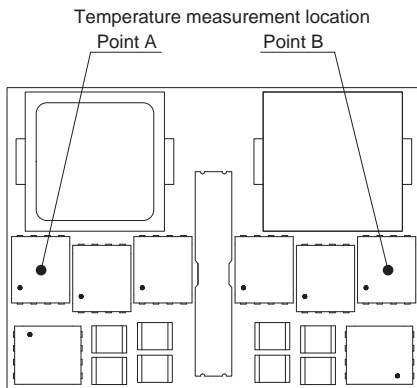

Fig.8.6 Temperature measurement location (BRFS100 · BRDS100)

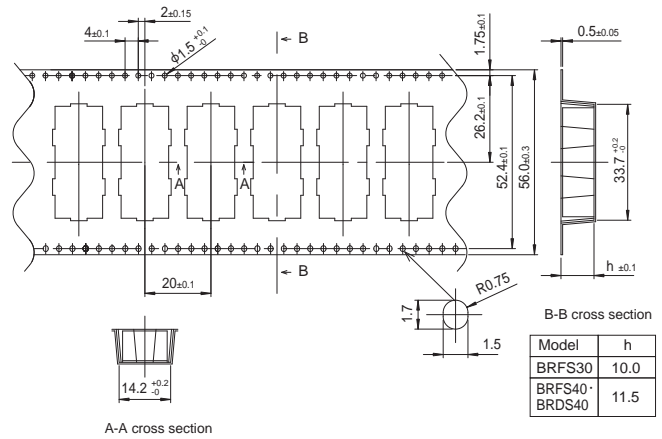

Fig.9.1 Taping dimensions of BRFS30/40 · BRDS40

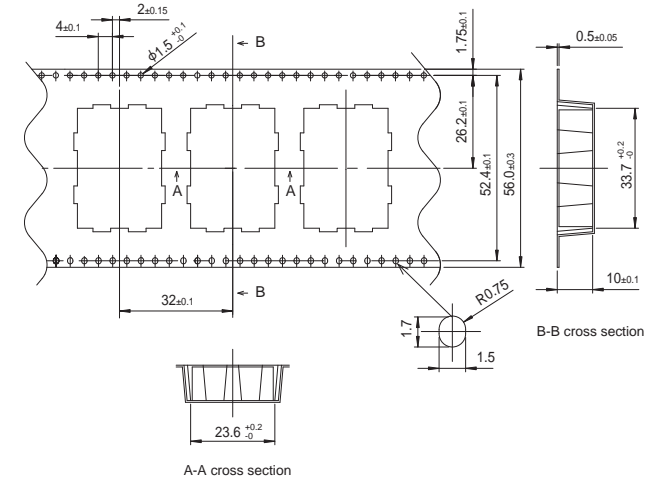

Fig.9.2 Taping dimensions of BRFS50/50L/60 · BRDS60

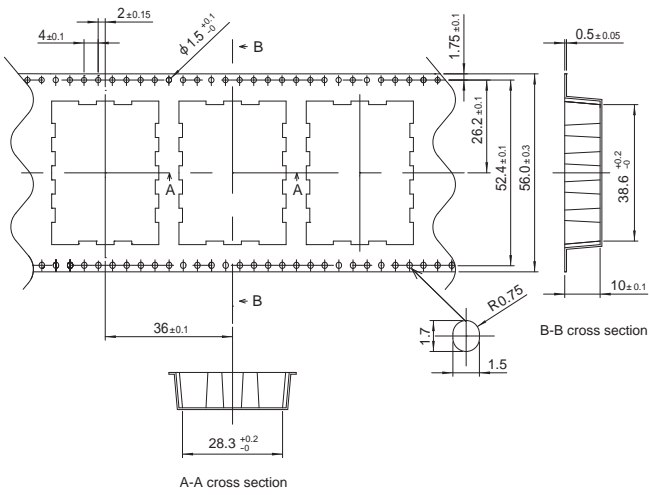
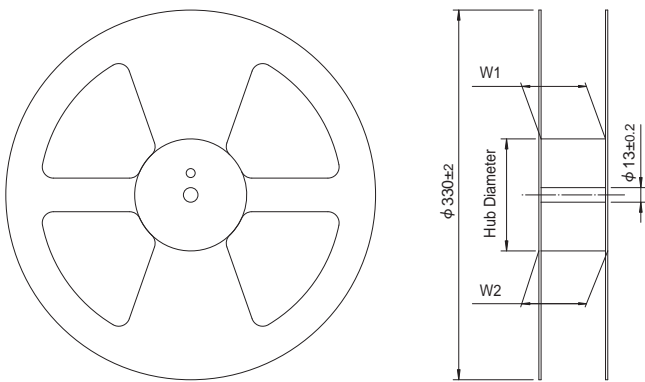

Fig.9.3 Taping dimensions of BRFS100 · BRDS100



Model	Tape Width [mm]	Hub Diameter [mm]	W1 [mm]	W2 [mm]
BRFS30/40 · BRDS40	56	100	57.4±1.0	61.4±1.0
BRFS50/50L/60 · BRDS60	56	150	57.5±1.0	61.5±1.0
BRFS100 · BRDS100	56	150	57.5±1.0	61.5±1.0

Fig.9.4 Reel dimensions

■ Please refer to specifications for the details of package information