

SC Series

Mating harness

Model	Harness model #	Contents	Connector	
			SCHA	SCDA
SC Series	H-SN-27	Harness for using remote signal ON/OFF function	CN1~CN4	CN1,CN2
	H-SN-28	Harness for using MAS,SLV,CTB,PCONT,COM terminal	CN5,CN6	CN3,CN4
	H-SN-29	Harness for using system ON/OFF function	CN7,CN8	CN5,CN6
	H-SN-30	Harness for using alarm / output voltage monitor terminal	CN9,CN10	CN7,CN8
	H-OU-35	Output harness	Output connector 1~20	Output connector 1~14
	H-PA-7	Harness for using parallel connection (SLAVE unit-SLAVE unit)	CN5,CN6	CN3,CN4
H-PA-8	Harness for using parallel connection (MASTER unit-SLAVE unit)	CN5,CN6	CN3,CN4	

●Model number
H-SN-27

Housing : 1-1318119-4 (Tyco Electronics AMP)
Pin : 1318105-1 or 1318107-1 (Tyco Electronics AMP)

●Type

A	B
1	1
2	2
3	3
4	4

●Wire

Pin #	Wire	AWG	Color	Length ℓ (mm)
A 1	UL1007	22	brown	2000
B 1	UL1007	22	green	2000
A 2	UL1007	22	red	2000
B 2	UL1007	22	blue	2000
A 3	UL1007	22	orange	2000
B 3	UL1007	22	purple	2000
A 4	UL1007	22	yellow	2000
B 4	UL1007	22	gray	2000

●Model number
H-SN-28

Housing : 1-1318118-6 (Tyco Electronics AMP)
Pin : 1318105-1 or 1318107-1 (Tyco Electronics AMP)

●Type

A	B
1	1
2	2
3	3
4	4
5	5
6	6

●Wire

Pin #	Wire	AWG	Color	Length ℓ (mm)
A 1	UL1007	22	brown	2000
B 1	-	-	-	-
A 2	UL1007	22	red	2000
B 2	-	-	-	-
A 3	UL1007	22	orange	2000
B 3	-	-	-	-
A 4	UL1007	22	yellow	2000
B 4	-	-	-	-
A 5	UL1007	22	green	2000
B 5	-	-	-	-
A 6	-	-	-	-
B 6	-	-	-	-

●Model number
H-SN-29

Housing : 1-1318119-3 (Tyco Electronics AMP)
Pin : 1318105-1 or 1318107-1 (Tyco Electronics AMP)

●Type

A	B
1	1
2	2
3	3

●Wire

Pin #	Wire	AWG	Color	Length ℓ (mm)
A 1	UL1007	22	brown	2000
B 1	-	-	-	-
A 2	-	-	-	-
B 2	-	-	-	-
A 3	UL1007	22	orange	2000
B 3	-	-	-	-

●Model number
H-SN-30

Housing : 2-1318119-3 (Tyco Electronics AMP)
Pin : 1318105-1 or 1318107-1 (Tyco Electronics AMP)

●Type

A	B
1	1
2	2
3	3

●Wire

Pin #	Wire	AWG	Color	Length ℓ (mm)
A 1	UL1007	22	brown	2000
B 1	-	-	-	-
A 2	UL1007	22	red	2000
B 2	UL1007	22	green	2000
A 3	UL1007	22	orange	2000
B 3	-	-	-	-

●Model number
H-OU-35

Housing : 1-179958-2 (Tyco Electronics AMP)
Pin : 179956-2 or 316041-2 (Tyco Electronics AMP)

●Type

1	
2	

●Wire

Pin #	Wire	AWG	Color	Length ℓ (mm)
1	UL1015	10	red	2000
2	UL1015	10	black	2000

●Model number
H-PA-7

Housing : 1-1318118-6 (Tyco Electronics AMP)
Pin : 1318105-1 or 1318107-1
(Tyco Electronics AMP)

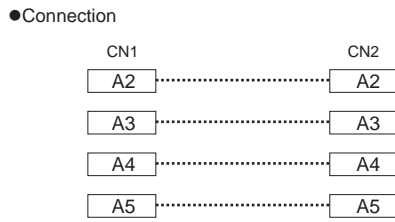
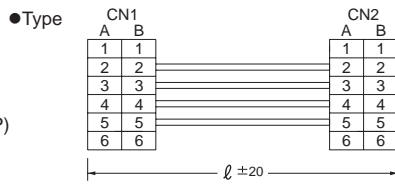

●Wire

	Pin #	Wire	AWG	Color	Length l (mm)
CN1	A 1	-	-	-	-
	B 1	-	-	-	-
	A 2	UL1007	22	red	400
	B 2	-	-	-	-
	A 3	UL1007	22	orange	400
	B 3	-	-	-	-
	A 4	UL1007	22	yellow	400
	B 4	-	-	-	-
	A 5	UL1007	22	green	400
	B 5	-	-	-	-
	A 6	-	-	-	-
	B 6	-	-	-	-
CN2	A 1	-	-	-	-
	B 1	-	-	-	-
	A 2	UL1007	22	red	400
	B 2	-	-	-	-
	A 3	UL1007	22	orange	400
	B 3	-	-	-	-
	A 4	UL1007	22	yellow	400
	B 4	-	-	-	-
	A 5	UL1007	22	green	400
	B 5	-	-	-	-
	A 6	-	-	-	-
	B 6	-	-	-	-

●Model number
H-PA-8

Housing : 1-1318118-6 (Tyco Electronics AMP)
Pin : 1318105-1 or 1318107-1
(Tyco Electronics AMP)

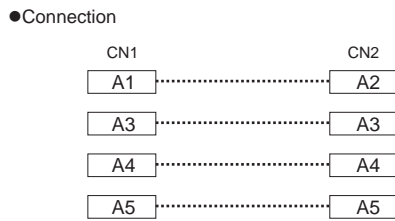
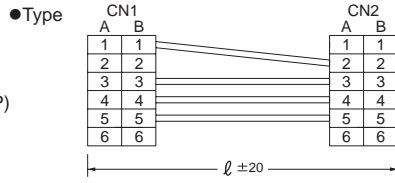

●Wire

	Pin #	Wire	AWG	Color	Length l (mm)
CN1	A 1	UL1007	22	brown	400
	B 1	-	-	-	-
	A 2	-	-	-	-
	B 2	-	-	-	-
	A 3	UL1007	22	orange	400
	B 3	-	-	-	-
	A 4	UL1007	22	yellow	400
	B 4	-	-	-	-
	A 5	UL1007	22	green	400
	B 5	-	-	-	-
	A 6	-	-	-	-
	B 6	-	-	-	-
CN2	A 1	-	-	-	-
	B 1	-	-	-	-
	A 2	UL1007	22	brown	400
	B 2	-	-	-	-
	A 3	UL1007	22	orange	400
	B 3	-	-	-	-
	A 4	UL1007	22	yellow	400
	B 4	-	-	-	-
	A 5	UL1007	22	green	400
	B 5	-	-	-	-
	A 6	-	-	-	-
	B 6	-	-	-	-

Fan unit

SC Series

★Several kind optional fan unit are prepared for SC series.
 This fan unit is used to distribute sufficient air for cooling single SC unit.

Fan unit type	Matching model	External
FAN-SCH-1	SCHA10000T-48	
FAN-SCH-2	SCHA10000T-48	
FAN-SCD-1	SCDA10000T-48	
FAN-SCD-2	SCDA10000T-48	

- ★ 1 Fan is delicate component, ageist impact stress such as throwing the unit, or drop the unit, careful handling is required to avoid failure.
- ★ 2 Please make sure there is not loose connection and cramping the harness wire between chassis.

1 External view

1.FAN-SCH-□

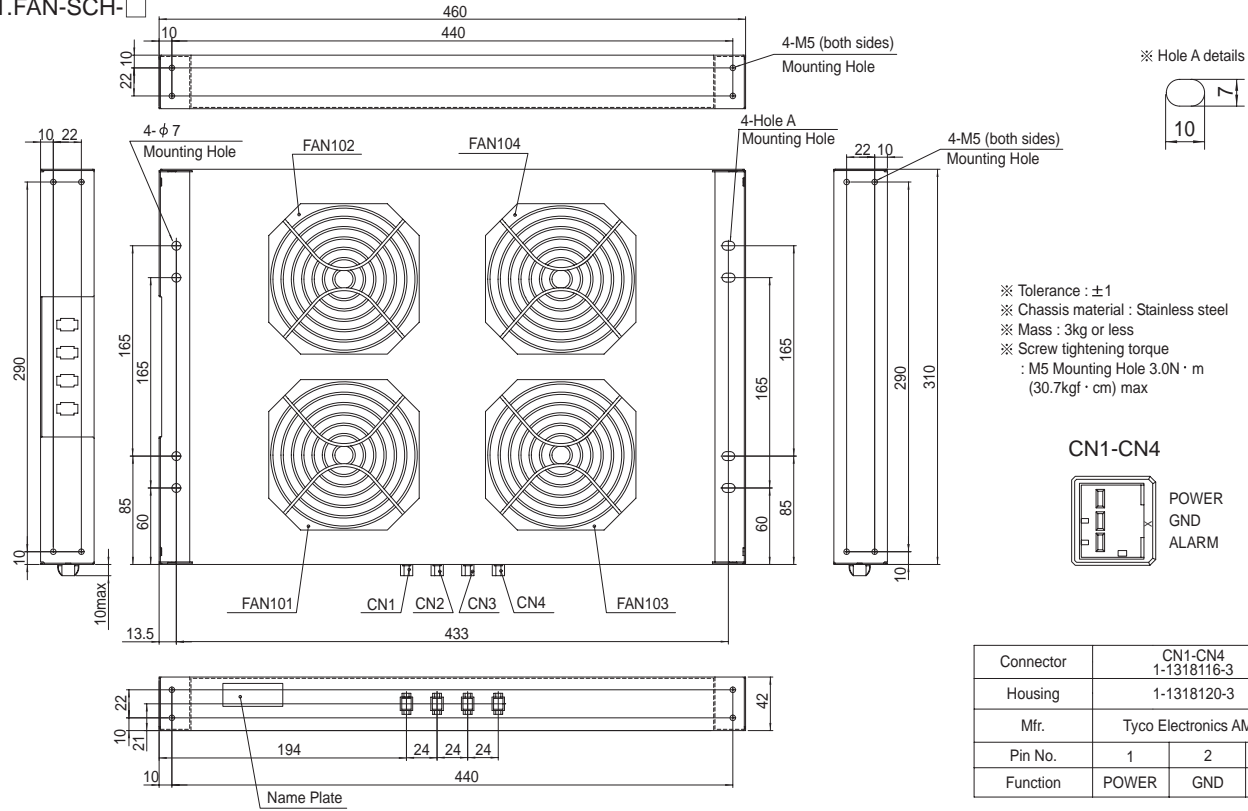

2.FAN-SCD-□

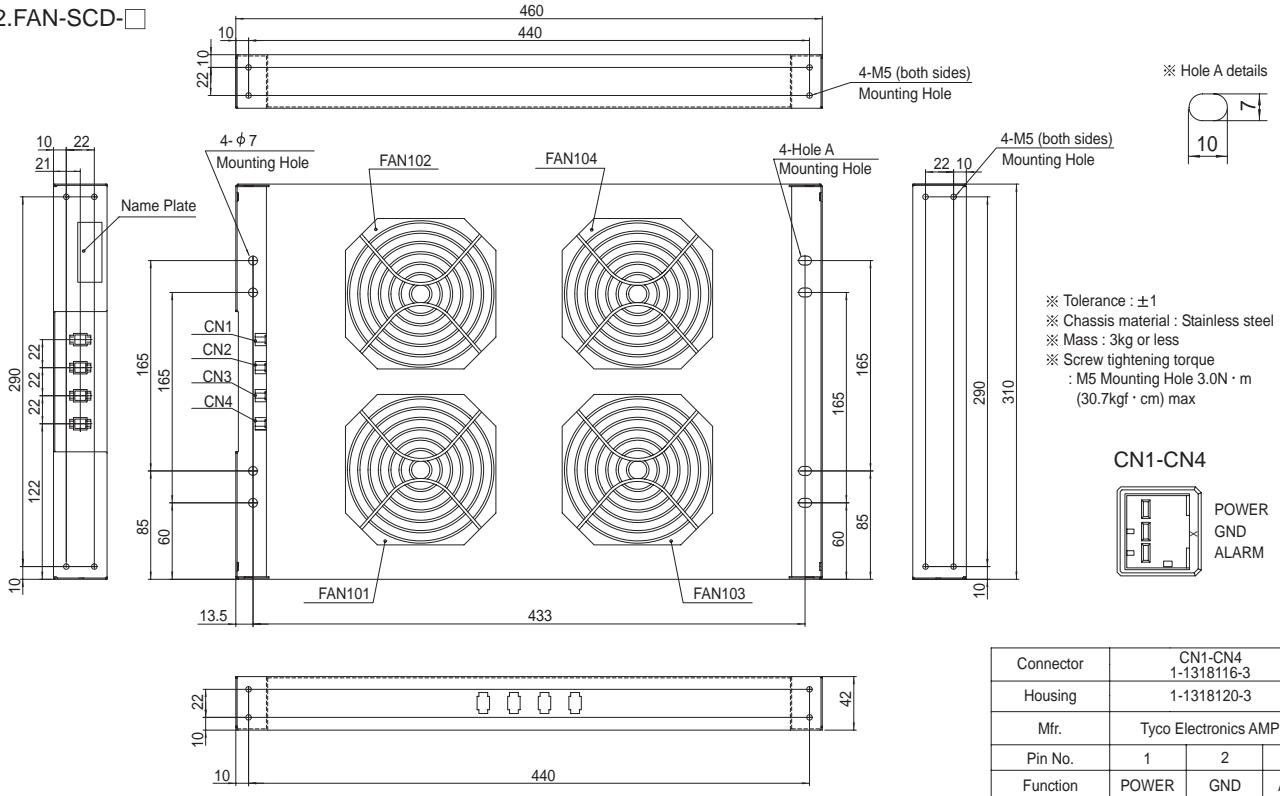

2 Block diagram

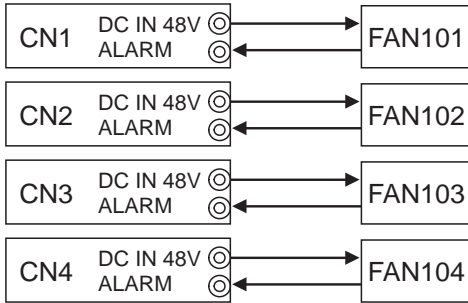

3 Specifications

■ Specifications is on Table 3.1.

Table 3.1 Specifications

ITEM	SPECIFICATIONS
INPUT VOLTAGE[V]	DC46.0-50.0 ※
INPUT CURRENT[A]	0.23/Connector (Total 0.92)
OPERATING TENP	0 to +70°C

※ You may use the output voltage of SC series

4 Fan alarm

■ Individual fan has built-in alarm function detecting the operation. Fan alarm specifications are shown in Table4.1. A connection for example is shown in Fig.4.1.

Table 4.1 Fan sensor specifications

ITEM	SPECIFICATIONS
OUTPUT	open collector output
PULL UP VOLTAGE[V]	60max ※
SINK CURRENT[ma]	5max

※ You can use output voltage of the SC series

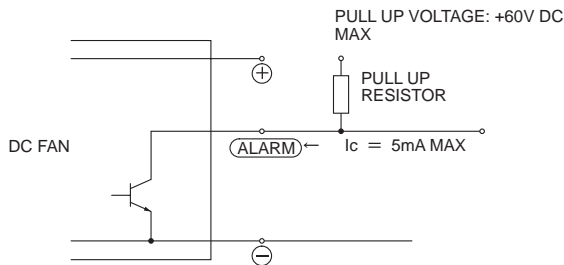

Fig.4.1 Fan alarm connection example

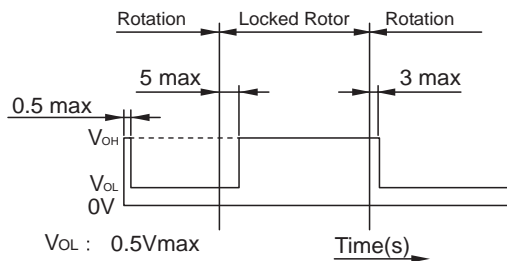

Fig.4.2 Fan alarm output wave form

5 Life time expectancy of the fan unit

■ Life time expectancy of the fan unit (R(t)90%) is shown in Fig.5.1.

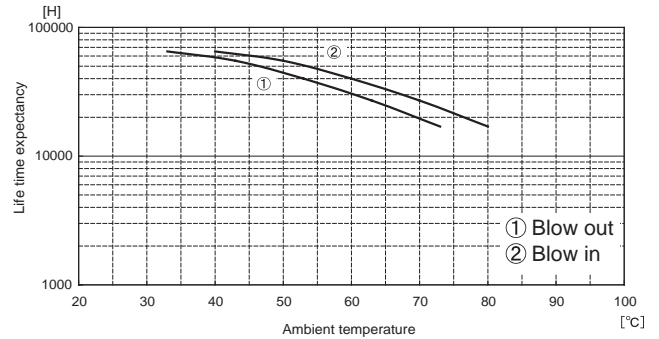
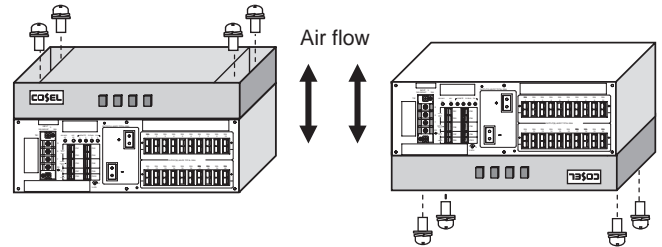

Fig.5.1 Life expectancy of fan unit

6 Installation method

■ The fan unit is screw-mountable either upside or downside of SC unit.

(1) Mounting instruction by using screws to SC series.



(2) Rack-mounting

The fan unit is needed 10mm or less clearance against SC unit chassis.

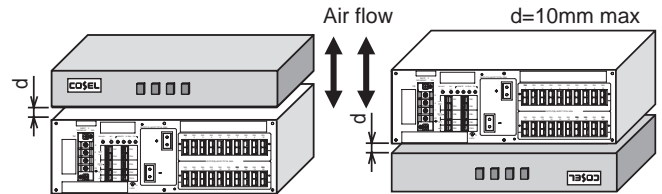

7 Life time expectancy of SC series

■ Life time expectancy with optional fan unit : 10 years

8 Operating Environment

■ Oil and other chemical liquid splashing environment may cause the performance degradation and failure.

SC Series Attachment

Plate model	Applicable to model	Note
F-SCD-1	SCDA10000T-48	For 19-inch rack (bracket type)
F-SCD-2	SCDA10000T-48	For 19-inch rack

Example of installation

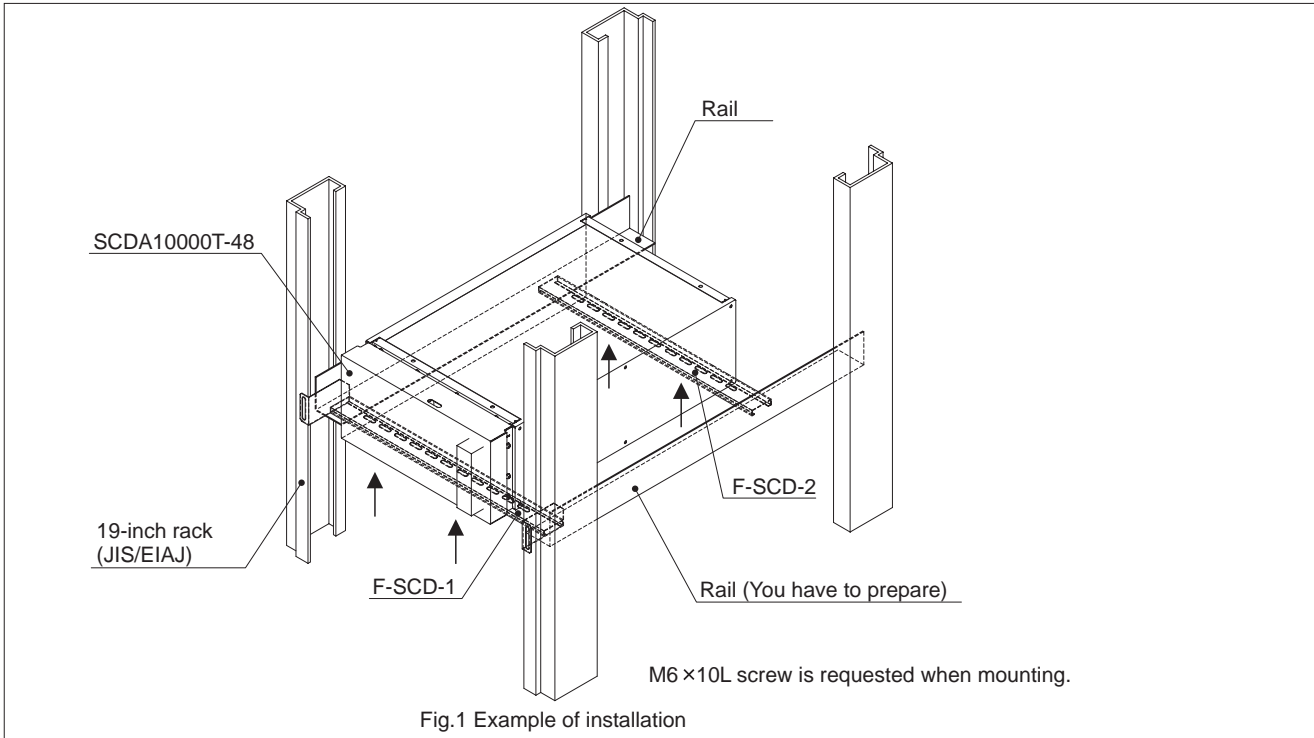

External view

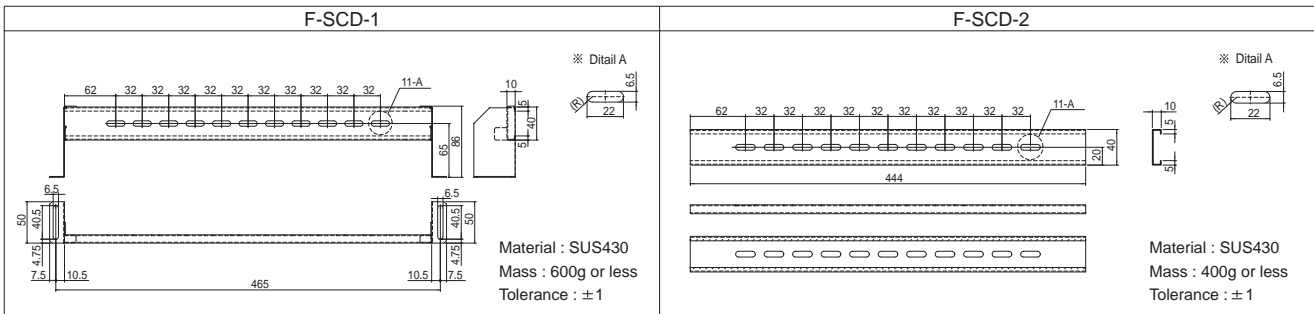

Mounting position

4 mounting position is available.
Mounting position and space distance a are on Table 1.

Table 1 position and space distance (mm)

Position	Distance a
A	115-118
B	83-93
C	51-61
D	19-29

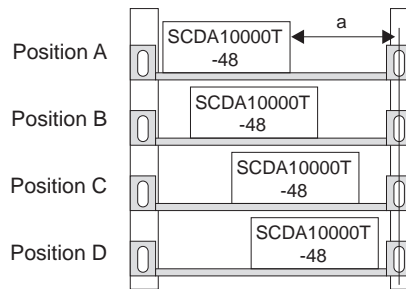

Front View

Others

- 19-inch rails are required for initial preparation.
- 2 units or more stack is not recommended mounting with F-SCD-1 and F-SCD-2.