

Heat sink

Heat sink is prepared in CBS series.

Chart: List of Heat sink for CBS series

No	Model	Size [mm]			Thermal resistance [°C/W]		Style
		H	W	D	Convection (0.1m/s)	Forced Air	
1	F-CBS-F1	12.7	57.9	61.5	7.5	Refer Fig.7	Vertical
2	F-CBS-F2	12.7	58.4	61.0			Horizontal
3	F-CBS-F3	25.4	57.9	61.5	4.6		Vertical
4	F-CBS-F4	25.4	58.4	61.0			Horizontal
5	F-CBS-F5	38.1	57.9	61.5	3.0		Vertical
6	F-CBS-F6	38.1	58.4	61.0			Horizontal

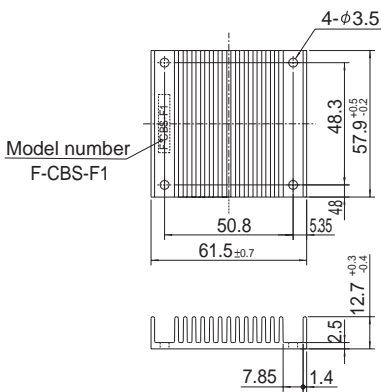

Fig.1 F-CBS-F1 external view

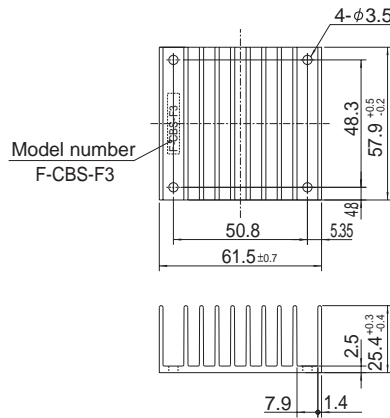

Fig.2 F-CBS-F3 external view

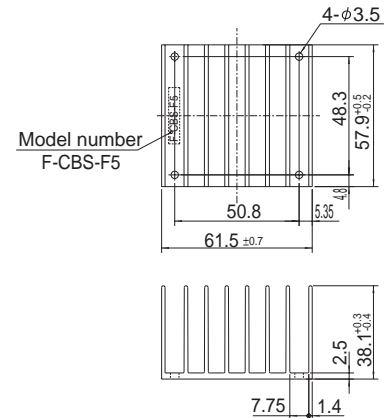

Fig.3 F-CBS-F5 external view

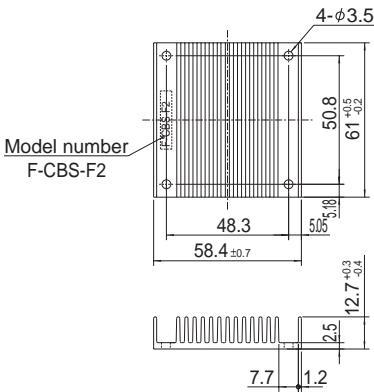

Fig.4 F-CBS-F2 external view

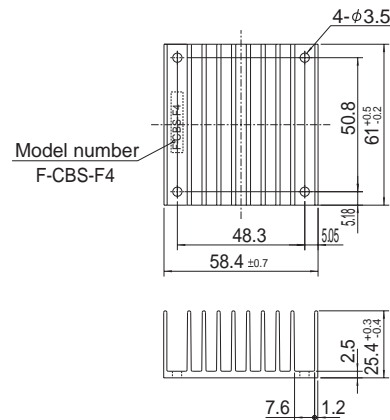

Fig.5 F-CBS-F4 external view

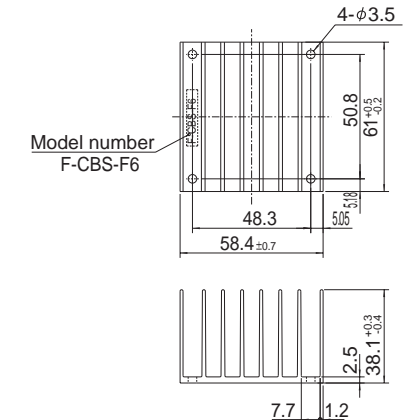

Fig.6 F-CBS-F6 external view

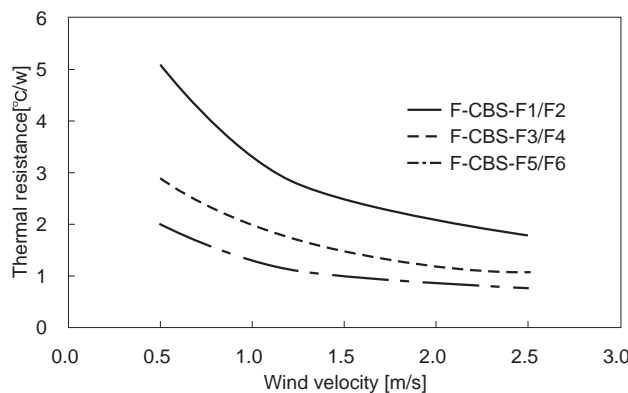

Fig.7 Thermal resistance of heat sink(Forced air)