

# SUCW1R5

SUC W 1R5 12 12 B P - □

① ② ③ ④ ⑤ ⑥ ⑦ ⑧

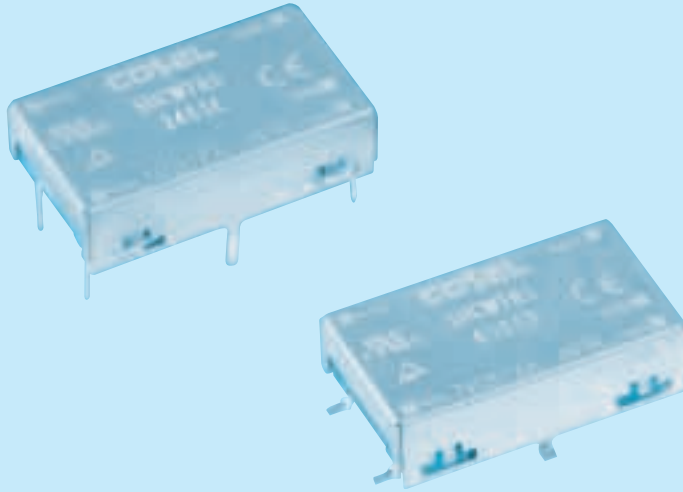

- ① Series name
  - ② Dual output
  - ③ Output wattage
  - ④ Input voltage
  - ⑤ Output voltage
  - ⑥ Mounting type  
B :SMD  
C :DIP
  - ⑦ Packing form  
Blank:Plastic cover  
P :Tray (SMD type)
  - ⑧ Optional  
C :with coating (only DIP type)\*
- \* Safety standards are pending

MODEL	SUCW1R50512	SUCW1R50515	SUCW1R51212	SUCW1R51215	SUCW1R52412	SUCW1R52415	SUCW1R54812	SUCW1R54815	
MAX OUTPUT WATTAGE[W]	1.56	1.5	1.56	1.5	1.56	1.5	1.56	1.5	
DC OUTPUT	VOLTAGE[V] *1	± 12 or +24	± 15 or +30	± 12 or +24	± 15 or +30	± 12 or +24	± 15 or +30	± 12 or +24	± 15 or +30
	CURRENT[A]	0.065	0.05	0.065	0.05	0.065	0.05	0.065	0.05

## SPECIFICATIONS

	MODEL	SUCW1R50512	SUCW1R50515	SUCW1R51212	SUCW1R51215	SUCW1R52412	SUCW1R52415	SUCW1R54812	SUCW1R54815	
INPUT	VOLTAGE[V]	DC4.5 - 9		DC9 - 18		DC18 - 36		DC36 - 76		
	CURRENT[A] *2	0.446typ	0.429typ	0.178typ	0.171typ	0.089typ	0.086typ	0.045typ	0.043typ	
	EFFICIENCY[%] *2	70typ	70typ	73typ	73typ	73typ	73typ	73typ	73typ	
OUTPUT	VOLTAGE[V]	± 12(+24)	± 15(+30)	± 12(+24)	± 15(+30)	± 12(+24)	± 15(+30)	± 12(+24)	± 15(+30)	
	CURRENT[A]	0.065	0.05	0.065	0.05	0.065	0.05	0.065	0.05	
	LINE REGULATION[mV]	60max	75max	60max	75max	60max	75max	60max	75max	
	LOAD REGULATION[mV]	600max	750max	600max	750max	600max	750max	600max	750max	
	RIPPLE[mVp-p]	-20 to +55°C *3	120max	120max	120max	120max	120max	120max	120max	120max
		-40 to -20°C *3	150max	150max	150max	150max	150max	150max	150max	150max
	RIPPLE NOISE[mVp-p]	-20 to +55°C *3	150max	150max	150max	150max	150max	150max	150max	150max
		-40 to -20°C *3	200max	200max	200max	200max	200max	200max	200max	200max
	TEMPERATURE REGULATION[mV]	-20 to +55°C	150max	180max	150max	180max	150max	180max	150max	180max
		-40 to +55°C	240max	290max	240max	290max	240max	290max	240max	290max
DRIFT[mV] *4	50max	60max	50max	60max	50max	60max	50max	60max		
START-UP TIME[ms]	20max (Minimum input, Io=100%)									
OUTPUT VOLTAGE ADJUSTMENT RANGE	Fixed (TRM pin open) ±5% adjustable by external VR									
OUTPUT VOLTAGE SETTING[V] (±5%)	11.40 - 12.60	14.25 - 15.75	11.40 - 12.60	14.25 - 15.75	11.40 - 12.60	14.25 - 15.75	11.40 - 12.60	14.25 - 15.75		
OVERCURRENT PROTECTION	Works over 105% of rating and recovers automatically									
ISOLATION	INPUT-OUTPUT	AC500V 1minute, Cutoff current = 10mA, DC500V 50MΩ min (20±15°C)								
	INPUT-CASE	AC500V 1minute, Cutoff current = 10mA, DC500V 50MΩ min (20±15°C)								
	OUTPUT-CASE	AC500V 1minute, Cutoff current = 10mA, DC500V 50MΩ min (20±15°C)								
ENVIRONMENT	OPERATING TEMP.,HUMID.AND ALTITUDE	-40 to +85°C, 20 - 95%RH (Non condensing) (Required Derating), 3,000m (10,000feet) max								
	STORAGE TEMP.,HUMID.AND ALTITUDE	-40 to +100°C, 20 - 95%RH (Non condensing), 9,000m (30,000feet) max								
	VIBRATION	10 - 55Hz, 98.0m/s <sup>2</sup> (10G), 3minutes period, 60minutes each along X, Y and Z axis								
	IMPACT	490.3m/s <sup>2</sup> (50G), 11ms, once each along X, Y and Z axis								
SAFETY	AGENCY APPROVALS	UL60950-1, C-UL, EN60950-1								
OTHERS	CASE SIZE/WEIGHT	22.4 × 7.0 × 13.2mm (W × H × D) / 3g max								
	COOLING METHOD	Convection/Forced air								

\*1 Output pins can be connected in series to make a 24V/30V output.  
 \*2 Rated input 5V, 12V, 24V or 48V DC Io=100%  
 \*3 Ripple and Ripple Noise is measured by using measuring board with capacitor with in 25mm from output pin terminals.  
 \*4 Drift is the change in DC output for an eight hour period after a half-hour warm-up at 25°C.  
 \* Parallel operation with other model is not possible.

External view

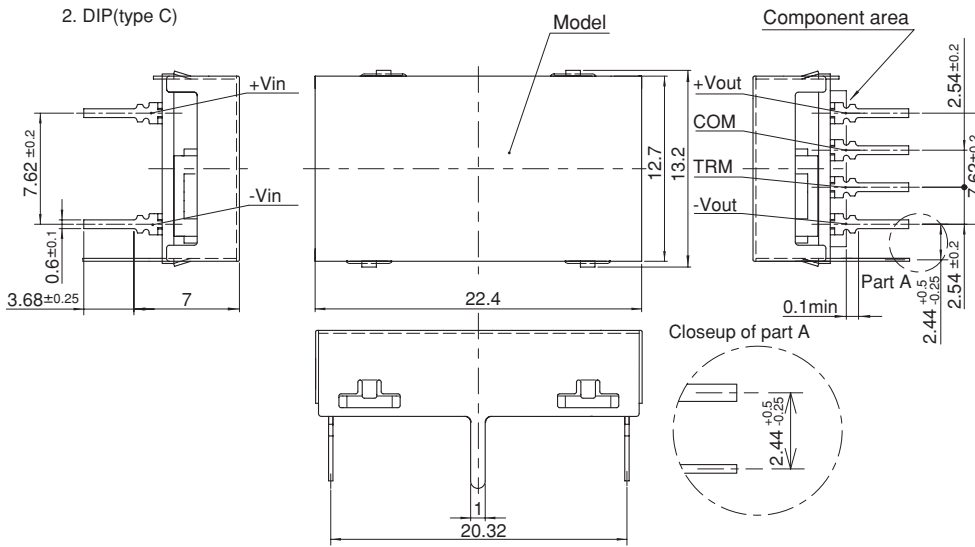
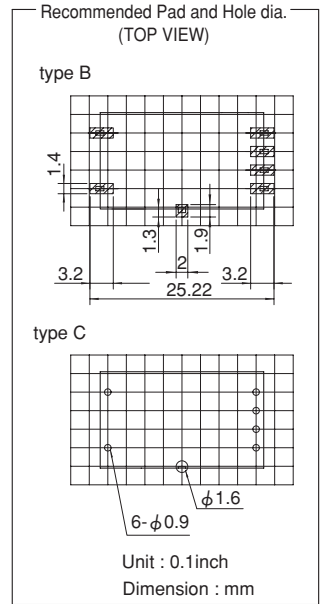
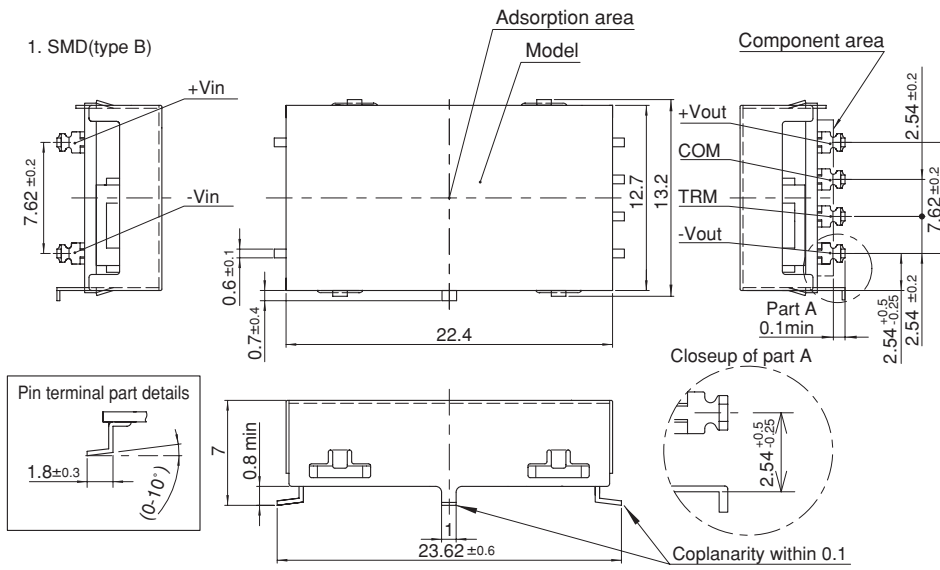

- ※ Tolerance ±0.5
- ※ Dimensions in mm
- ※ Pin terminal thickness : 0.3±0.1
- ※ Pin terminal material : Copper alloy
- ※ Plating treatment of terminal : Lead free plating
- ※ Case thickness : 0.2±0.05
- ※ Case material : Brass
- ※ Plating treatment of case : Nickel plating
- ※ Please keep enough creepage distance with the pattern on PCB and other components.
- ※ Mass 3g less

# SUCW3

SUC W 3 12 12 B P - □

① ② ③ ④ ⑤ ⑥ ⑦ ⑧

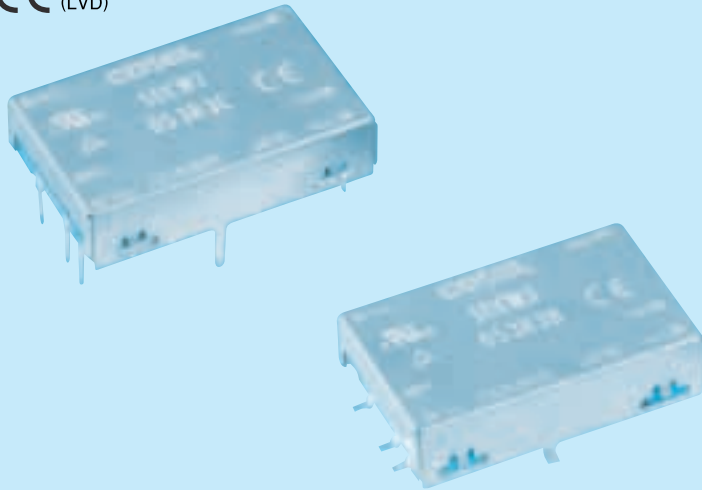

- ① Series name
  - ② Dual output
  - ③ Output wattage
  - ④ Input voltage
  - ⑤ Output voltage
  - ⑥ Mounting type  
B :SMD  
C :DIP
  - ⑦ Packing form  
Blank:Plastic cover  
P :Tray (SMD type)
  - ⑧ Optional  
G :Capacitor between Input and Output is removed.  
C :with coating (only DIP type)\*
- \* Safety standards are pending

MODEL	SUCW30512	SUCW30515	SUCW31212	SUCW31215	SUCW32412	SUCW32415	SUCW34812	SUCW34815
MAX OUTPUT WATTAGE[W]	3.12	3	3.12	3	3.12	3	3.12	3
DC OUTPUT	VOLTAGE[V]*1	±12 or +24	±15 or +30	±12 or +24	±15 or +30	±12 or +24	±12 or +24	±15 or +30
	CURRENT[A]	0.13	0.1	0.13	0.1	0.13	0.13	0.1

## SPECIFICATIONS

MODEL	SUCW30512	SUCW30515	SUCW31212	SUCW31215	SUCW32412	SUCW32415	SUCW34812	SUCW34815	
INPUT	VOLTAGE[V]	DC4.5 - 9		DC9 - 18		DC18 - 36		DC36 - 76	
	CURRENT[A]	*2 0.844typ	0.811typ	0.343typ	0.329typ	0.172typ	0.165typ	0.086typ	
	EFFICIENCY[%]	*2 74typ	74typ	76typ	76typ	76typ	76typ	76typ	
OUTPUT	VOLTAGE[V]	±12(+24)	±15(+30)	±12(+24)	±15(+30)	±12(+24)	±15(+30)	±12(+24)	
	CURRENT[A]	0.13	0.1	0.13	0.1	0.13	0.1	0.13	
	LINE REGULATION[mV]	60max	75max	60max	75max	60max	75max	60max	
	LOAD REGULATION[mV]	600max	750max	600max	750max	600max	750max	600max	
	RIPPLE[mVp-p]	-20 to +55°C *3	120max	120max	120max	120max	120max	120max	120max
		-40 to -20°C *3	150max	150max	150max	150max	150max	150max	150max
	RIPPLE NOISE[mVp-p]	-20 to +55°C *3	150max	150max	150max	150max	150max	150max	150max
		-40 to -20°C *3	200max	200max	200max	200max	200max	200max	200max
	TEMPERATURE REGULATION[mV]	-20 to +55°C	150max	180max	150max	180max	150max	180max	150max
		-40 to +55°C	240max	290max	240max	290max	240max	290max	240max
DRIFT[mV]	*4 50max	60max	50max	60max	50max	60max	50max		
START-UP TIME[ms]	20max (Minimum input, Io=100%)								
OUTPUT VOLTAGE ADJUSTMENT RANGE	Fixed (TRM pin open) ±5% adjustable by external VR								
OUTPUT VOLTAGE SETTING[V] (±5%)	11.40 - 12.60	14.25 - 15.75	11.40 - 12.60	14.25 - 15.75	11.40 - 12.60	14.25 - 15.75	11.40 - 12.60	14.25 - 15.75	
PROTECTION CIRCUIT AND OTHERS	OVERCURRENT PROTECTION	Works over 105% of rating and recovers automatically							
	REMOTE ON/OFF	Provided (Negative logic L : ON, H : OFF)							
ISOLATION	INPUT-OUTPUT	AC500V 1minute, Cutoff current = 10mA, DC500V 50MΩ min (20±15°C)							
	INPUT-CASE	AC500V 1minute, Cutoff current = 10mA, DC500V 50MΩ min (20±15°C)							
	OUTPUT-CASE	AC500V 1minute, Cutoff current = 10mA, DC500V 50MΩ min (20±15°C)							
ENVIRONMENT	OPERATING TEMP.,HUMID.AND ALTITUDE	-40 to +85°C, 20 - 95%RH (Non condensing) (Required Derating), 3,000m (10,000feet) max							
	STORAGE TEMP.,HUMID.AND ALTITUDE	-40 to +100°C, 20 - 95%RH (Non condensing), 9,000m (30,000feet) max							
	VIBRATION	10 - 55Hz, 98.0m/s <sup>2</sup> (10G), 3minutes period, 60minutes each along X, Y and Z axis							
	IMPACT	490.3m/s <sup>2</sup> (50G), 11ms, once each along X, Y and Z axis							
SAFETY	AGENCY APPROVALS	UL60950-1, C-UL, EN60950-1							
OTHERS	CASE SIZE/WEIGHT	25 × 7.0 × 16.1mm (W × H × D) / 5g max							
	COOLING METHOD	Convection/Forced air							

\*1 Output pins can be connected in series to make a 24V/30V output.  
 \*2 Rated input 5V, 12V, 24V or 48V DC Io=100%  
 \*3 Ripple and Ripple Noise is measured by using measuring board with capacitor with in 25mm from output pin terminals.  
 \*4 Drift is the change in DC output for an eight hour period after a half-hour warm-up at 25°C.  
 \* Parallel operation with other model is not possible.

External view

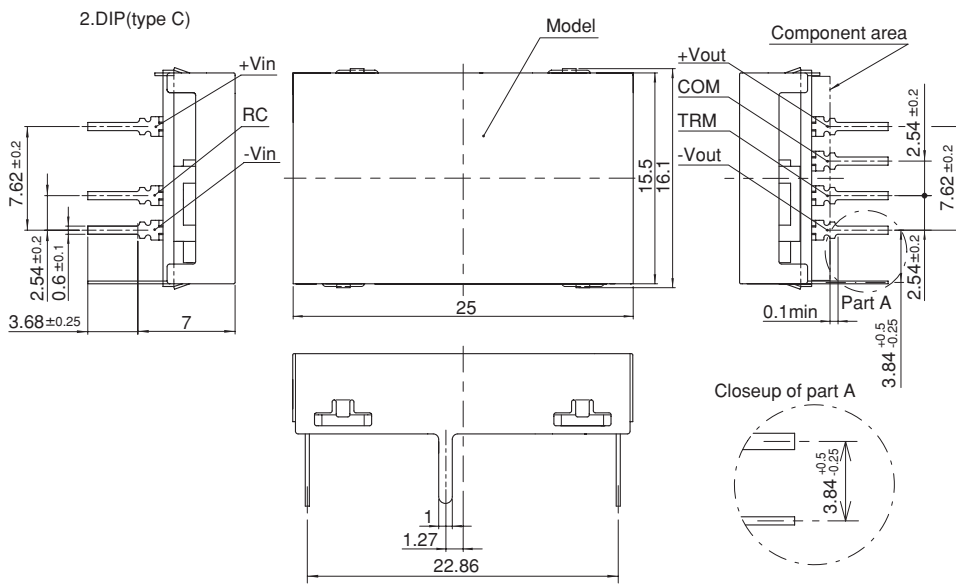
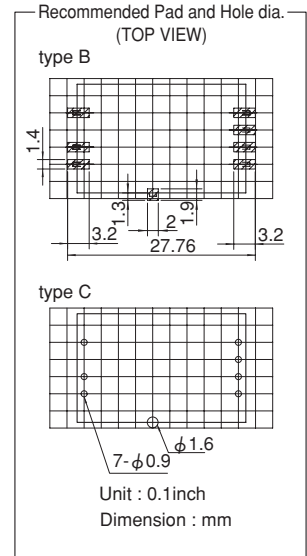
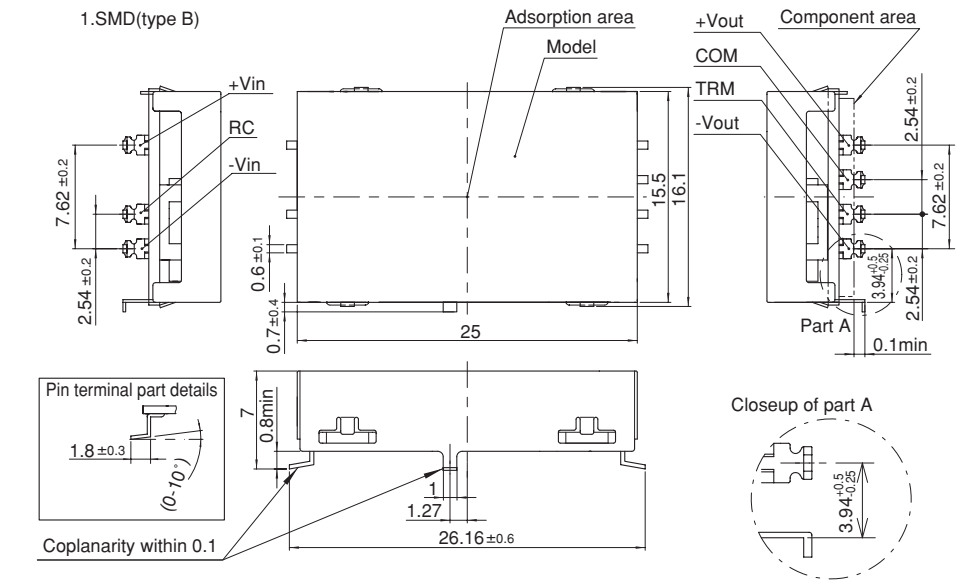

- ※ Tolerance ±0.5
- ※ Dimensions in mm
- ※ Pin terminal thickness : 0.3±0.1
- ※ Pin terminal material : Copper alloy
- ※ Plating treatment of terminal : Lead free plating
- ※ Case thickness : 0.2±0.05
- ※ Case material : Brass
- ※ Plating treatment of case : Nickel plating
- ※ Please keep enough creepage distance with the pattern on PCB and other components.
- ※ Mass 5g less

# SUCW6

SUC W 6 12 12 B P - □

① ② ③ ④ ⑤ ⑥ ⑦ ⑧



- ① Series name
  - ② Dual output
  - ③ Output wattage
  - ④ Input voltage
  - ⑤ Output voltage
  - ⑥ Mounting type  
B :SMD  
C :DIP
  - ⑦ Packing form  
Blank:Plastic cover  
P :Tray (SMD type)
  - ⑧ Optional  
G :Capacitor between Input and Output is removed.  
C :with coating (only DIP type)\*
- \* Safety standards are pending

MODEL	SUCW60512	SUCW60515	SUCW61212	SUCW61215	SUCW62412	SUCW62415	SUCW64812	SUCW64815
MAX OUTPUT WATTAGE[W]	6	6	6	6	6	6	6	6
DC OUTPUT	VOLTAGE[V] *1	± 12 or +24	± 15 or +30	± 12 or +24	± 15 or +30	± 12 or +24	± 12 or +24	± 15 or +30
	CURRENT[A]	0.25	0.2	0.25	0.2	0.25	0.25	0.2

## SPECIFICATIONS

MODEL	SUCW60512	SUCW60515	SUCW61212	SUCW61215	SUCW62412	SUCW62415	SUCW64812	SUCW64815		
INPUT	VOLTAGE[V]	DC4.5 - 9		DC9 - 18		DC18 - 36		DC36 - 76		
	CURRENT[A] *2	1.538typ	1.538typ	0.588typ	0.588typ	0.291typ	0.291typ	0.145typ		
	EFFICIENCY[%] *2	78typ	78typ	85typ	85typ	86typ	86typ	86typ		
OUTPUT	VOLTAGE[V]	± 12(+24)	± 15(+30)	± 12(+24)	± 15(+30)	± 12(+24)	± 15(+30)	± 12(+24)	± 15(+30)	
	CURRENT[A]	0.25	0.2	0.25	0.2	0.25	0.2	0.25	0.2	
	LINE REGULATION[mV]	60max	75max	60max	75max	60max	75max	60max	75max	
	LOAD REGULATION[mV]	600max	750max	600max	750max	600max	750max	600max	750max	
	RIPPLE[mVp-p]	-20 to +55°C *3	120max	120max	120max	120max	120max	120max	120max	120max
		-40 to -20°C *3	150max	150max	150max	150max	150max	150max	150max	150max
	RIPPLE NOISE[mVp-p]	-20 to +55°C *3	150max	150max	150max	150max	150max	150max	150max	150max
		-40 to -20°C *3	200max	200max	200max	200max	200max	200max	200max	200max
	TEMPERATURE REGULATION[mV]	-20 to +55°C	150max	180max	150max	180max	150max	180max	150max	180max
		-40 to +55°C	240max	290max	240max	290max	240max	290max	240max	290max
DRIFT[mV] *4	50max	60max	50max	60max	50max	60max	50max	60max		
START-UP TIME[ms]	20max (Minimum input, I <sub>o</sub> =100%)									
OUTPUT VOLTAGE ADJUSTMENT RANGE	Fixed (TRM pin open) ±5% adjustable by external VR									
OUTPUT VOLTAGE SETTING[V] (±5%)	11.40 - 12.60	14.25 - 15.75	11.40 - 12.60	14.25 - 15.75	11.40 - 12.60	14.25 - 15.75	11.40 - 12.60	14.25 - 15.75		
PROTECTION CIRCUIT AND OTHERS	OVERCURRENT PROTECTION	Works over 105% of rating and recovers automatically								
	REMOTE ON/OFF	Provided (Negative logic L : ON, H : OFF)								
ISOLATION	INPUT-OUTPUT	AC500V 1minute, Cutoff current = 10mA, DC500V 50MΩ min (20±15°C)								
	INPUT-CASE	AC500V 1minute, Cutoff current = 10mA, DC500V 50MΩ min (20±15°C)								
	OUTPUT-CASE	AC500V 1minute, Cutoff current = 10mA, DC500V 50MΩ min (20±15°C)								
ENVIRONMENT	OPERATING TEMP.,HUMID.AND ALTITUDE	-40 to +85°C, 20 - 95%RH (Non condensing) (Required Derating), 3.000m (10.000feet) max								
	STORAGE TEMP.,HUMID.AND ALTITUDE	-40 to +100°C, 20 - 95%RH (Non condensing), 9.000m (30.000feet) max								
	VIBRATION	10 - 55Hz, 98.0m/s <sup>2</sup> (10G), 3minutes period, 60minutes each along X, Y and Z axis								
	IMPACT	490.3m/s <sup>2</sup> (50G), 11ms, once each along X, Y and Z axis								
SAFETY	AGENCY APPROVALS	UL60950-1, C-UL, EN60950-1								
OTHERS	CASE SIZE/WEIGHT	32.6 × 7.0 × 19.1mm (W × H × D) / 7g max								
	COOLING METHOD	Convection/Forced air								

\*1 Output pins can be connected in series to make a 24V/30V output.  
 \*2 Rated input 5V, 12V, 24V or 48V DC I<sub>o</sub>=100%  
 \*3 Ripple and Ripple Noise is measured by using measuring board with capacitor with in 25mm from output pin terminals.  
 \*4 Drift is the change in DC output for an eight hour period after a half-hour warm-up at 25°C.  
 \* Parallel operation with other model is not possible.

External view

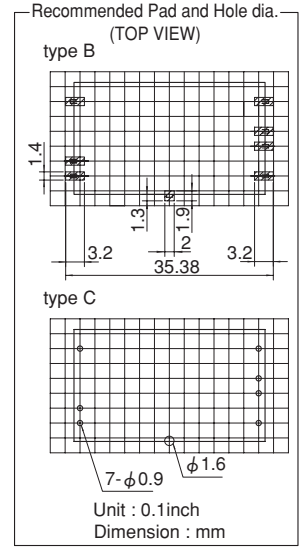
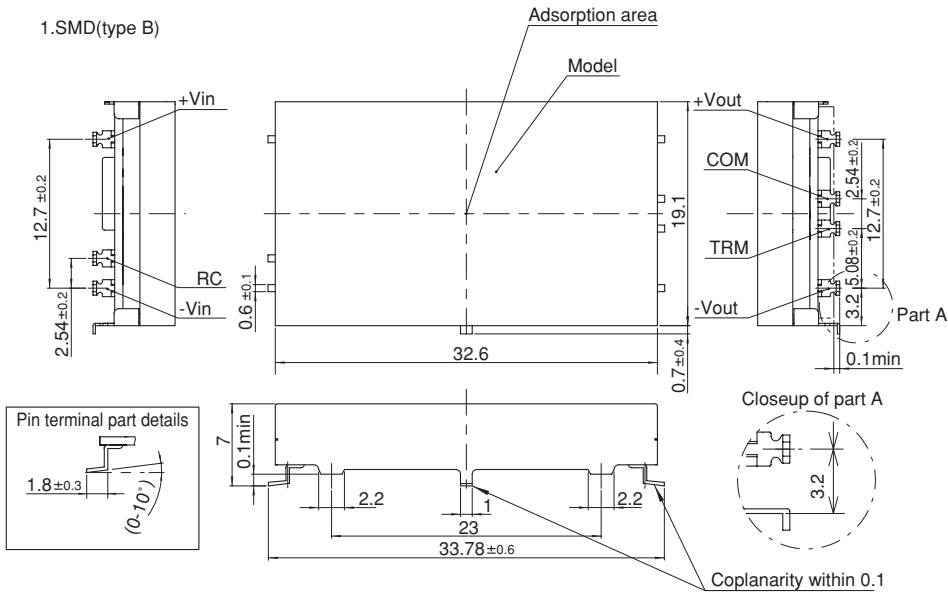

- ※ Tolerance ±0.5
- ※ Dimensions in mm
- ※ Pin terminal thickness : 0.3±0.1
- ※ Pin terminal material : Copper alloy
- ※ Plating treatment of terminal : Lead free plating
- ※ Case thickness : 0.2±0.05
- ※ Case material : Brass
- ※ Plating treatment of case : Nickel plating
- ※ Please keep enough creepage distance with the pattern on PCB and other components.
- ※ Mass 7g less

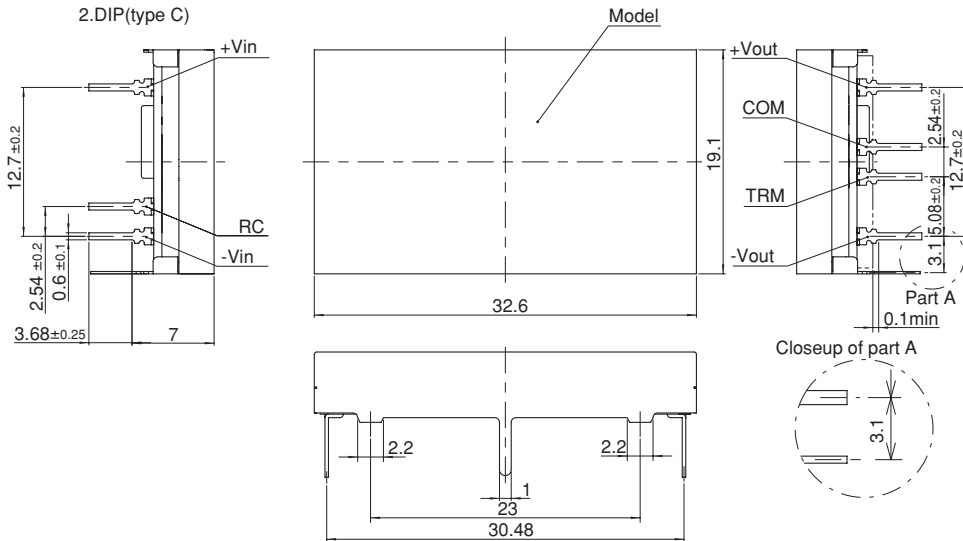

# SUCW10

SUC W 10 12 12 B P - □

① ② ③ ④ ⑤ ⑥ ⑦ ⑧

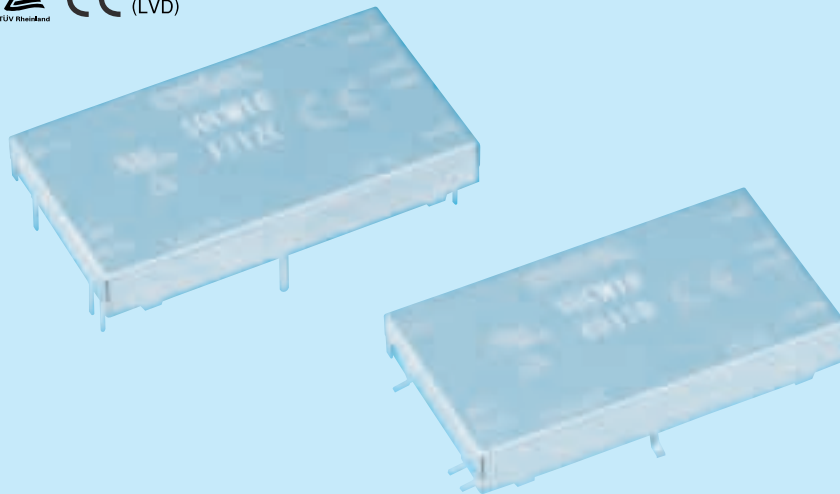

- ① Series name
  - ② Dual output
  - ③ Output wattage
  - ④ Input voltage
  - ⑤ Output voltage
  - ⑥ Mounting type  
B :SMD  
C :DIP
  - ⑦ Packing form  
Blank:Plastic cover  
P :Tray(SMD type)
  - ⑧ Optional  
G :Capacitor between Input and Output is removed.  
C :with coating (only DIP type)\*
- \* Safety standards are pending

MODEL	SUCW100512	SUCW100515	SUCW101212	SUCW101215	SUCW102412	SUCW102415	SUCW104812	SUCW104815
MAX OUTPUT WATTAGE[W]	10.8	10.5	10.8	10.5	10.8	10.5	10.8	10.5
DC OUTPUT	VOLTAGE[V] *1	± 12 or +24	± 15 or +30	± 12 or +24	± 15 or +30	± 12 or +24	± 12 or +24	± 15 or +30
	CURRENT[A]	0.45	0.35	0.45	0.35	0.45	0.45	0.35

## SPECIFICATIONS

MODEL	SUCW100512	SUCW100515	SUCW101212	SUCW101215	SUCW102412	SUCW102415	SUCW104812	SUCW104815	
INPUT	VOLTAGE[V]	DC4.5 - 9		DC9 - 18		DC18 - 36		DC36 - 76	
	CURRENT[A] *2	2.51typ	2.44typ	1.05typ	1.02typ	0.523typ	0.509typ	0.262typ	
	EFFICIENCY[%] *2	86typ	86typ	86typ	86typ	86typ	86typ	86typ	
OUTPUT	VOLTAGE[V]	± 12(+24)	± 15(+30)	± 12(+24)	± 15(+30)	± 12(+24)	± 15(+30)	± 12(+24)	
	CURRENT[A]	0.45	0.35	0.45	0.35	0.45	0.35	0.45	
	LINE REGULATION[mV]	60max	75max	60max	75max	60max	75max	60max	
	LOAD REGULATION[mV]	600max	750max	600max	750max	600max	750max	600max	
	RIPPLE[mVp-p]	-20 to +55°C *3	120max	120max	120max	120max	120max	120max	120max
		-40 to -20°C *3	150max	150max	150max	150max	150max	150max	150max
	RIPPLE NOISE[mVp-p]	-20 to +55°C *3	150max	150max	150max	150max	150max	150max	150max
		-40 to -20°C *3	200max	200max	200max	200max	200max	200max	200max
	TEMPERATURE REGULATION[mV]	-20 to +55°C	150max	180max	150max	180max	150max	180max	150max
		-40 to +55°C	240max	290max	240max	290max	240max	290max	240max
DRIFT[mV] *4	50max	60max	50max	60max	50max	60max	50max		
START-UP TIME[ms]	20max (Minimum input, I <sub>o</sub> =100%)								
OUTPUT VOLTAGE ADJUSTMENT RANGE	Fixed (TRM pin open) ±5% adjustable by external VR								
OUTPUT VOLTAGE SETTING[V] (±5%)	11.40 - 12.60	14.25 - 15.75	11.40 - 12.60	14.25 - 15.75	11.40 - 12.60	14.25 - 15.75	11.40 - 12.60	14.25 - 15.75	
PROTECTION CIRCUIT AND OTHERS	OVERCURRENT PROTECTION	Works over 105% of rating and recovers automatically							
	REMOTE ON/OFF	Provided (Negative logic L : ON, H : OFF)							
ISOLATION	INPUT-OUTPUT	AC500V 1minute, Cutoff current = 10mA, DC500V 50MΩ min (20±15°C)							
	INPUT-CASE	AC500V 1minute, Cutoff current = 10mA, DC500V 50MΩ min (20±15°C)							
	OUTPUT-CASE	AC500V 1minute, Cutoff current = 10mA, DC500V 50MΩ min (20±15°C)							
ENVIRONMENT	OPERATING TEMP.,HUMID.AND ALTITUDE	-40 to +85°C, 20 - 95%RH (Non condensing) (Required Derating), 3,000m (10,000feet) max							
	STORAGE TEMP.,HUMID.AND ALTITUDE	-40 to +100°C, 20 - 95%RH (Non condensing), 9,000m (30,000feet) max							
	VIBRATION	10 - 55Hz, 98.0m/s <sup>2</sup> (10G), 3minutes period, 60minutes each along X, Y and Z axis							
	IMPACT	490.3m/s <sup>2</sup> (50G), 11ms, once each along X, Y and Z axis							
SAFETY	AGENCY APPROVALS	UL60950-1, C-UL, EN60950-1							
OTHERS	CASE SIZE/WEIGHT	40.2 × 7.0 × 22.0mm (W × H × D) / 10g max							
	COOLING METHOD	Convection/Forced air							

\*1 Output pins can be connected in series to make a 24V/30V output.  
 \*2 Rated input 5V, 12V, 24V or 48V DC I<sub>o</sub>=100%  
 \*3 Ripple and Ripple Noise is measured by using measuring board with capacitor with in 25mm from output pin terminals.  
 \*4 Drift is the change in DC output for an eight hour period after a half-hour warm-up at 25°C.  
 \* Parallel operation with other model is not possible.

External view

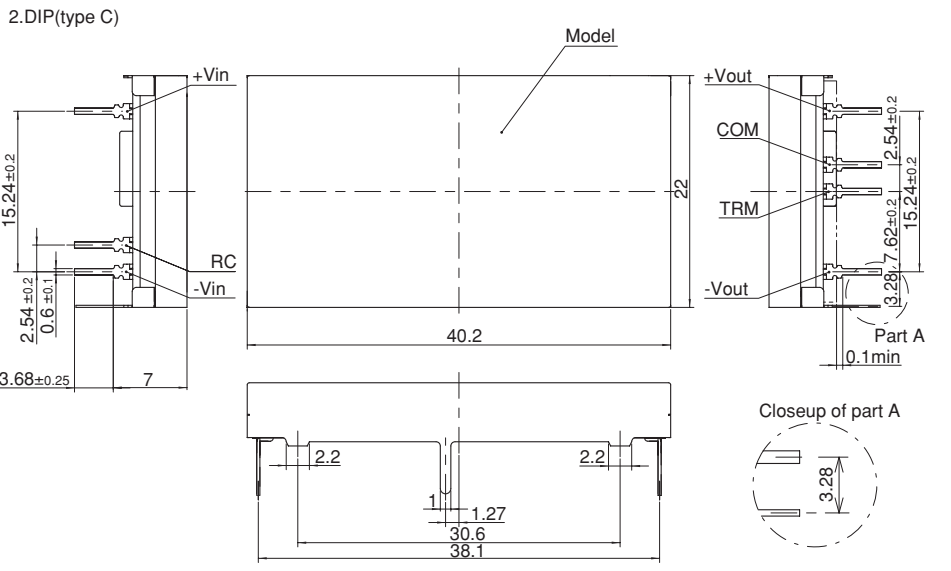
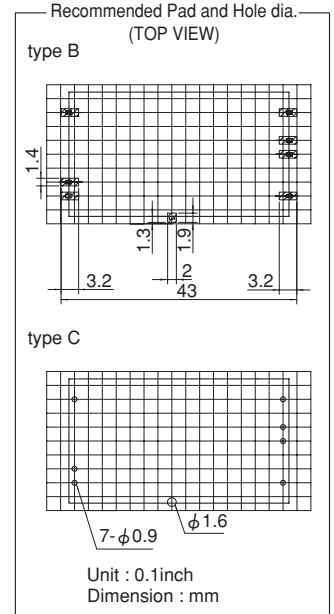
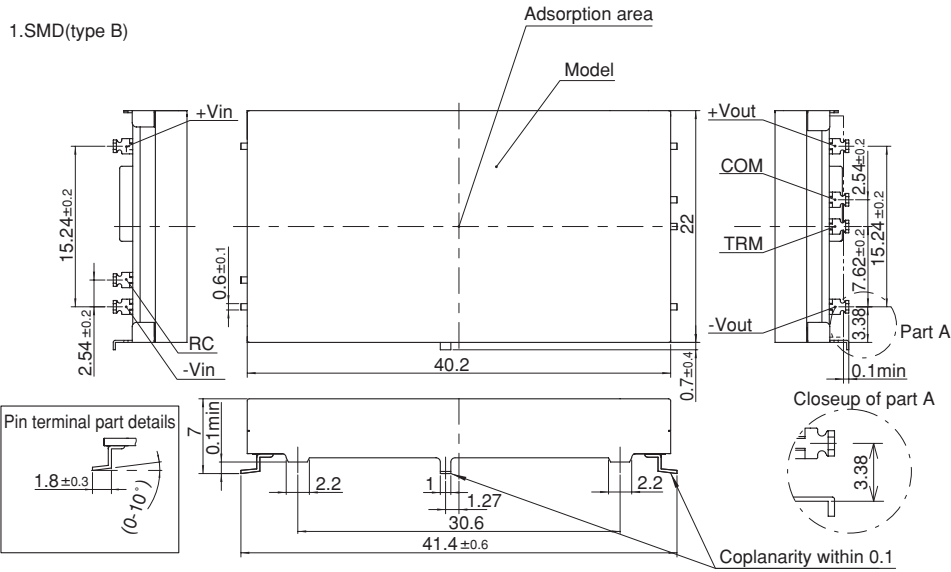

- ※ Tolerance ±0.5
- ※ Dimensions in mm
- ※ Pin terminal thickness : 0.3±0.1
- ※ Pin terminal material : Copper alloy
- ※ Plating treatment of terminal : Lead free plating
- ※ Case thickness : 0.2±0.05
- ※ Case material : Brass
- ※ Plating treatment of case : Nickel plating
- ※ Please keep enough creepage distance with the pattern on PCB and other components.
- ※ Mass 10g less