

# NBM series

NBM -10 -471 -□

① ② ③ ④

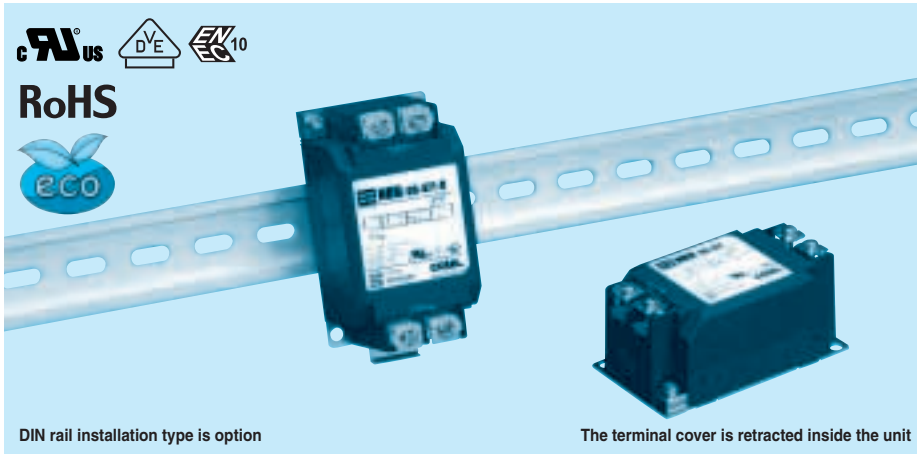

DIN rail installation type is option

The terminal cover is retracted inside the unit

- ① Model Name
- ② Rated Current
- ③ Line to ground capacitor code: See table 1.1.

table 1.1 Line to ground capacitor code

Code	Leakage Current (Input 125/250V 60Hz)	Line to ground capacitor (nominal value)
000	5 $\mu$ A / 10 $\mu$ A max	Not Provided
101	12.5 $\mu$ A / 25 $\mu$ A max	100pF
221	25 $\mu$ A / 50 $\mu$ A max	220pF
331	37.5 $\mu$ A / 75 $\mu$ A max	330pF
471	50 $\mu$ A / 100 $\mu$ A max	470pF

\* When the line to ground capacitor code is different, the attenuation characteristic is different.

- ④ Options
- D: DIN rail installation type

\* The dimensions change when the option is set. Refer to External view.

## Features of NBM series

### Low leakage current type, Withstand voltage 4,000VAC (2-stage filter)

- Single Phase 250 VAC
- Push down type terminal block

## Specifications

No.	Items	NBM-06-471	NBM-10-471	NBM-16-471	NBM-20-471	NBM-30-471
1	Rated Voltage[V]	AC 1 $\phi$ 250 / DC250				
2	Rated Current[A]	6	10	16	20	30
3	Test Voltage (Terminal-Mounting Plate)	4,000 VAC (Cutoff Current = 20mA), 1minute at room temperature and humidity				
4	Isolation Resistance (Terminal-Mounting Plate)	500 VDC 100M $\Omega$ min at room temperature and humidity				
5	Leakage current 125/250V 60Hz	50 $\mu$ A/100 $\mu$ A max				
6	Voltage drop	1.0V max				
7	Safety agency approval temperatures	-25 to +85 $^{\circ}$ C (Refer to Derating Curve)				
8	Operating temperature	-40 to +85 $^{\circ}$ C (Refer to Derating Curve)				
9	Operating humidity	20 to 95%RH (Non condensing)				
10	Storage temperature/humidity	-40 to +85 $^{\circ}$ C/20 to 95%RH (Non condensing)				
11	Vibration	10 to 55Hz, 19.6m/s $^2$ (2G), 3min. Period, 1hour each X, Y and Z axis				
12	Impact	196.1m/s $^2$ (20G), 11ms Once each X, Y and Z axis				
13	Safety agency approvals	UL1283, CSA C22.2 No.8 (C-UL), DIN EN60939 VDE0565 Teil3-1, ENEC (At only AC input)				
14	Case size (without projection) /Weight	53x41x92 mm [2.09x1.61x3.62 inches] (WxHxD) /270g max (Option : -D refer to external view)				

## Circuit Diagram

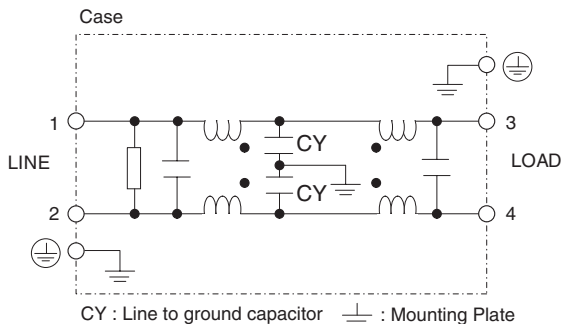

## Derating Curve

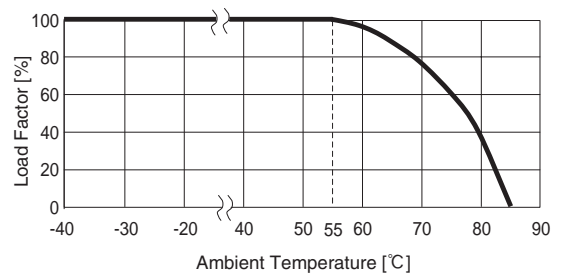

**External view**

As this product is adopted push-down type terminal block, this appearance is as follows.

- ①The terminal cover is retracted inside the unit.
- ②The screws for connecting the terminals are held in the up right position.

**Standard Type**

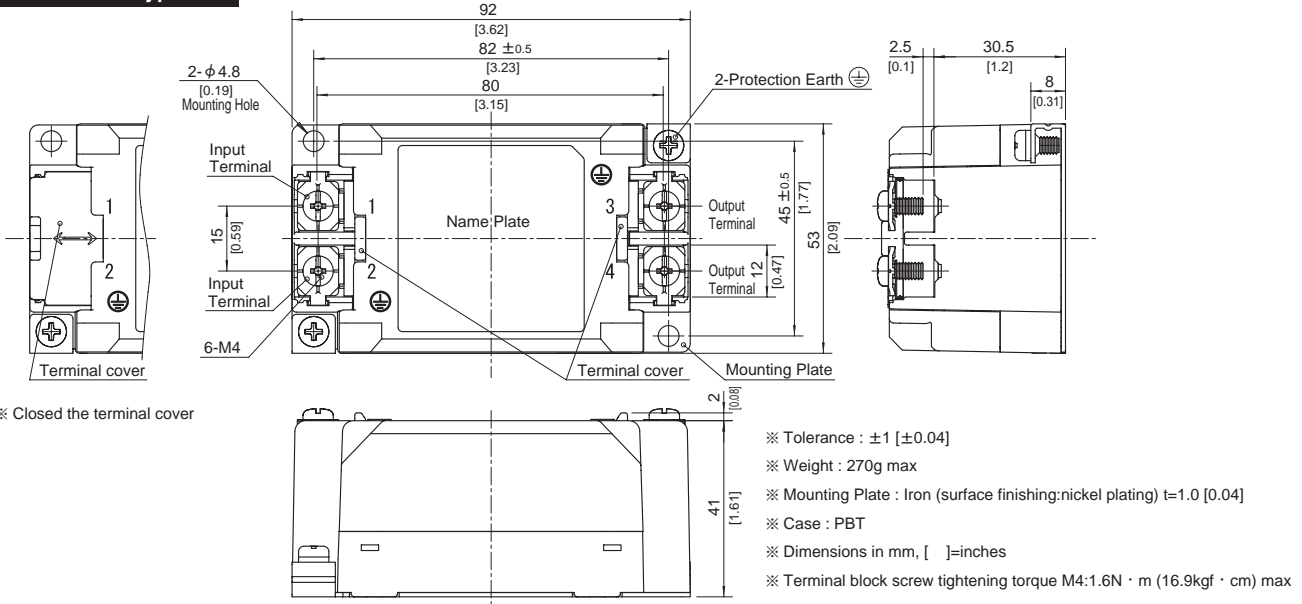

**DIN rail installation Type**

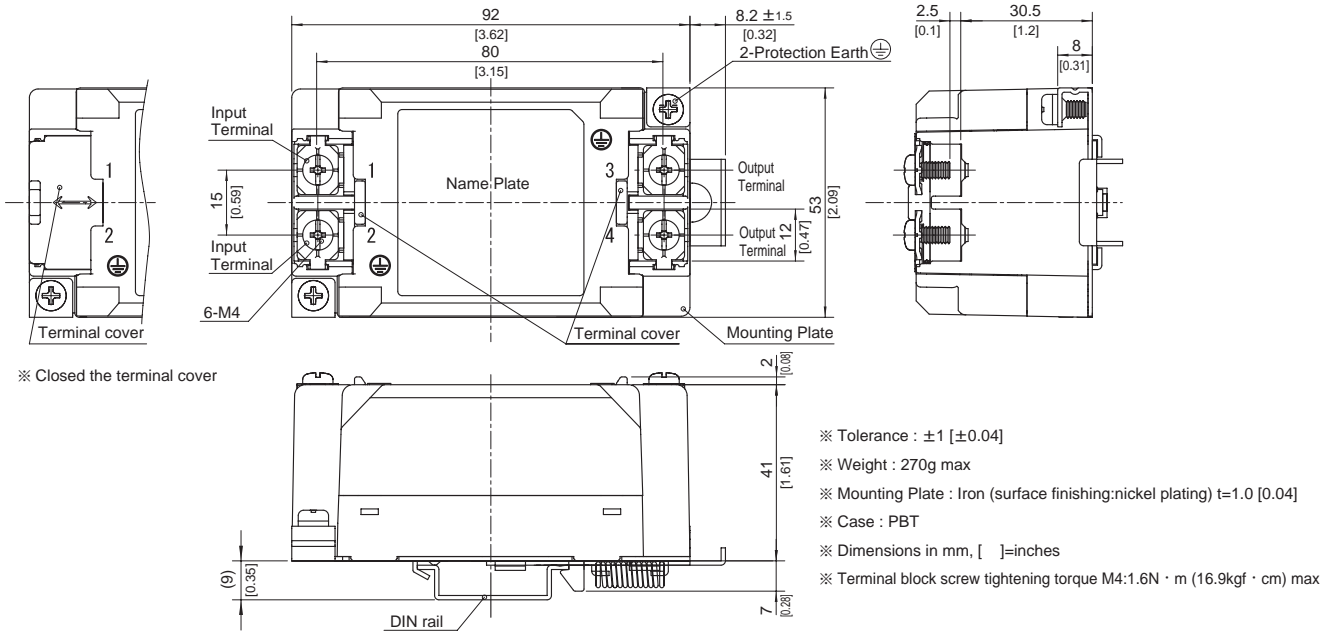

**■Note when installing the EMI/EMC Filter on a DIN rail.**

When the EMI/EMC Filter is grounded through the DIN rail, the proper noise attenuation may not be achieved.

Be sure to connect the protection earth (PE) of the EMI/EMC Filter body to the earth.

