

# LGA50A

LG A 50 A -5 -□

① ② ③ ④ ⑤ ⑥

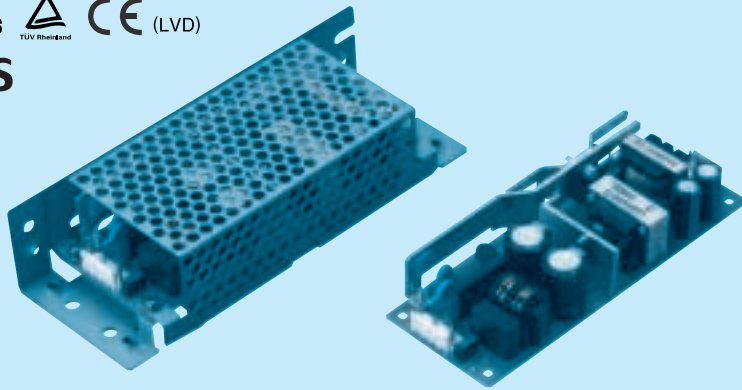

**Recommended Noise Filter  
NAC-06-472**



High voltage pulse noise type : NAP series  
Low leakage current type : NAM series  
\*The Noise Filter is recommended to connect with several devices.

- ① Series name
- ② Single output
- ③ Output wattage
- ④ 100/120V input
- ⑤ Output voltage
- ⑥ Optional
- C :with Coating
- G :Low leakage current
- H :with the function to be acceptable to output peak current (only 24V)
- J1 :VH(J.S.T.)connector type
- S :with Chassis
- SN:with Chassis & cover
- Y :with Potentiometer

This power supply is manufactured by SMD technology.The stress to P.C.B like twisting or bending causes the defect of the unit,so handle the unit with care.

MODEL	LGA50A-5	LGA50A-12	LGA50A-24	LGA50A-24-H
MAX OUTPUT WATTAGE[W]	50	51.6	60	60
DC OUTPUT	5V 10A	12V 4.3A	24V 2.5A	24V 2.5 (Peak 3.2) A

## SPECIFICATIONS

	MODEL	LGA50A-5	LGA50A-12	LGA50A-24	LGA50A-24-H	
INPUT	VOLTAGE[V]	AC85 - 132 1 φ (Refer to Instruction Manual 1.1, and 3.2 Derating)				
	CURRENT[A]	ACIN 100V 1.3typ (Io=100%)				
	FREQUENCY[Hz]	47 - 440 (Refer to Instruction Manual 1.1)				
	EFFICIENCY[%]	ACIN 100V 79.0typ (Io=100%)	82.0typ (Io=100%)	85.0typ (Io=100%)	85.0typ (Io=100%)	
	INRUSH CURRENT[A]	ACIN 100V 30typ (Io=100%), (At cold start), (Ta= 25°C)				
	LEAKAGE CURRENT[ma]	0.5max (ACIN 100V, 60Hz, Io=100%, According to IEC60950-1 and DEN-AN)				
OUTPUT	VOLTAGE[V]	5	12	24	24	
	CURRENT[A]	*3 10.0	4.3	2.5	2.5 (Peak 3.2)	
	LINE REGULATION[mV]	20max	48max	96max	96max	
	LOAD REGULATION[mV]	40max	100max	150max	150max	
	RIPPLE[mVp-p]	0 to +50°C *4	80max	120max	120max	240max
		-10 - 0°C *1	140max	160max	160max	320max
	RIPPLE NOISE[mVp-p]	0 to +50°C *4	120max	150max	150max	300max
		-10 - 0°C *1	160max	180max	180max	360max
	TEMPERATURE REGULATION[mV]	0 to +50°C *4	50max	120max	240max	240max
		-10 to +50°C *4	60max	150max	290max	290max
	DRIFT[mV]	*2 20max	48max	96max	96max	
	START-UP TIME[ms]	200max (ACIN 100V, Io=100%)				
HOLD-UP TIME[ms]	20typ (ACIN 100V, Io=100%)					
OUTPUT VOLTAGE ADJUSTMENT RANGE[V]	Fixed ("Y"which can be adjusted the output is available as optional ± 10%)					
OUTPUT VOLTAGE SETTING[V]	4.90 - 5.30	11.50 - 12.50	23.00 - 25.00	23.00 - 25.00		
PROTECTION CIRCUIT AND OTHERS	OVERCURRENT PROTECTION	Works over 105% of rating (works over 101% of peak current at option -H) and recovers automatically				
	OVERVOLTAGE PROTECTION	5.75 - 7.00	13.80 - 16.80	27.60 - 35.00	27.60 - 35.00	
	OPERATING INDICATION	Not provided				
	REMOTE SENSING	Not provided				
ISOLATION	REMOTE ON/OFF	Not provided				
	INPUT-OUTPUT	AC2,000V 1minute. Cutoff current = 10mA, DC500V 50MΩ min (At Room Temperature)				
	INPUT-FG	AC2,000V 1minute. Cutoff current = 10mA, DC500V 50MΩ min (At Room Temperature)				
ENVIRONMENT	OUTPUT-FG	AC500V 1minute. Cutoff current = 25mA, DC500V 50MΩ min (At Room Temperature)				
	OPERATING TEMP.,HUMID.AND ALTITUDE	-10 to +60°C, 20 - 90%RH (Non condensing) (Refer to DERATING CURVE), 3,000m (10,000feet) max				
	STORAGE TEMP.,HUMID.AND ALTITUDE	-20 to +75°C, 20 - 90%RH (Non condensing), 9,000m (30,000feet) max				
	VIBRATION	10 - 55Hz, 19.6m/s <sup>2</sup> (2G), 3minutes period, 60minutes each along X, Y and Z axis				
SAFETY AND NOISE REGULATIONS	IMPACT	196.1m/s <sup>2</sup> (20G), 11ms, once each X, Y and Z axis				
	AGENCY APPROVALS	UL60950-1, C-UL (CSA60950-1), EN60950-1 Complies with DEN-AN				
	CE MARKING	Low Voltage Directive				
	CONDUCTED NOISE	Complies with FCC-B, VCCI-B, CISPR-B, EN55011-B, EN55022-B				
OTHERS	CASE SIZE/WEIGHT	50 x 28.5 x 132mm (W x H x D) / 160g max (without chassis and cover)				
	COOLING METHOD	Convection				

\*1 This is the value that measured on measuring board with capacitor of 22 μF at 150mm from output terminal.  
Measured by 20MHz oscilloscope or Ripple-Noise meter (Equivalent to KEISOKU-GIKEN: RM-103).

\*2 Drift is the change in DC output for an eight hour period after a half-hour warm-up at 25°C, with the input voltage held constant at the rated input/output.

\*3 Peak loading for 10sec.And Duty 35% max.or less is acceptable if the total wattage is less than the rated wattage (24V:60W).  
Refer to instruction Manual 5. In detail.

\*4 Only output 24VDC model is applied that the upper temperature limit is 45°C.  
\* Avoid prolonged use under over - load.  
\* Parallel operation with other model is not possible.  
\* Derating is required when operated with chassis and cover.  
\* A sound may occur from power supply at pulse loading.

Block diagram

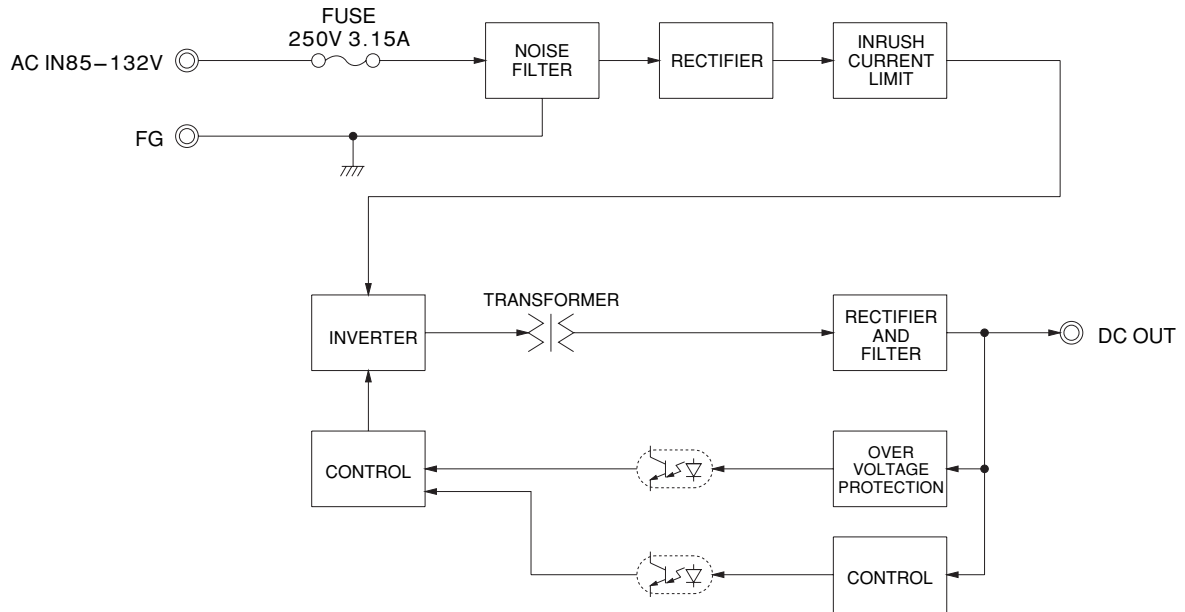

External view

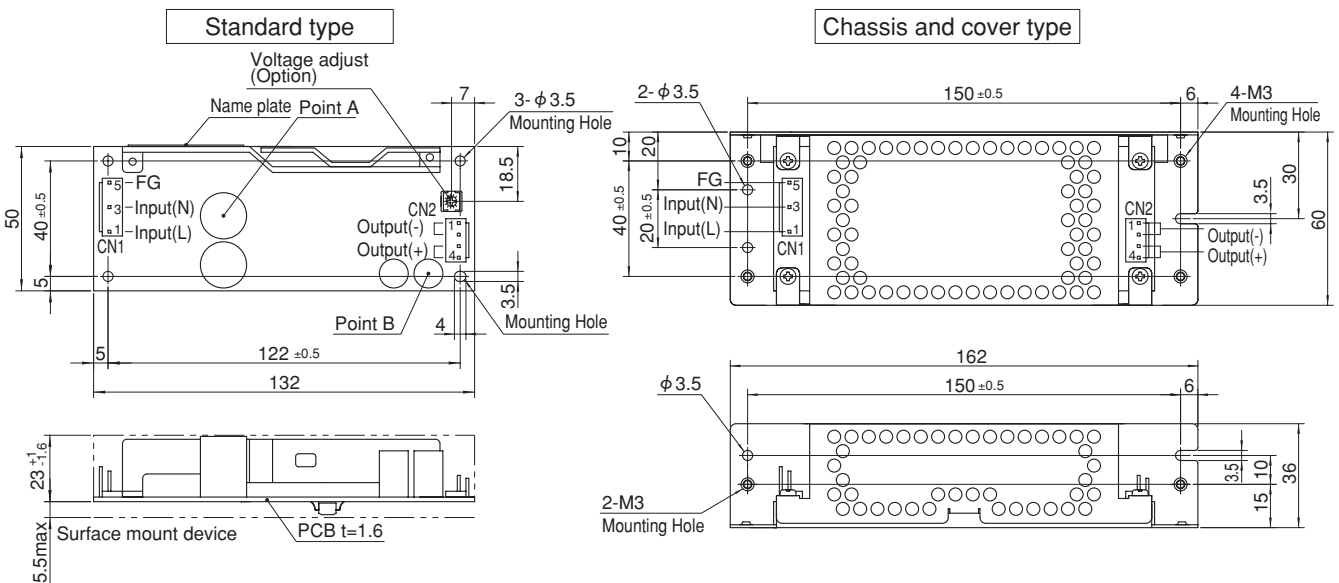

※ This power supply is manufactured by SMD technology. The stress to P.C.B like twisting or bending causes the defect of the unit, so handle the unit with care. Take care for SMD parts on the back to come in contact because of the vibration and not to break down.

※ Use the spacer of 8mm length or more.  
 ※ 4 Mounting holes are existing.

I/O Connector	Mating connector	Terminal
CN1	1-1123722-5	Chain 1123721-1
		Loose 1318912-1
CN2	1-1123722-4	Chain 1123721-1
		Loose 1318912-1

(Mfr: Tyco Electronics AMP)

※ I/O Connector is Mfr Tyco Electronics AMP  
 ※ Option: -J1; VH(J.S.T) connector type.  
 Refer to instruction Manual 5.

<PIN CONNECTION>

CN1		CN2	
Pin No.	Input	Pin No.	Output
1	AC(L)	1, 2	-V
2			
3	AC(N)	3, 4	+V
4			
5	FG		

※ Keep drawing current per pin below 5A for CN2.

※ Mounting torque: 0.6N.m(6.3kgf.cm) max

※ Tolerance : ±1

※ Weight: 160g max (without chassis and cover)

※ PCB material / thickness: CEM3 / 1.6mm

※ Optional chassis and cover material : Electric galvanizing steel board.

※ Dimensions is mm

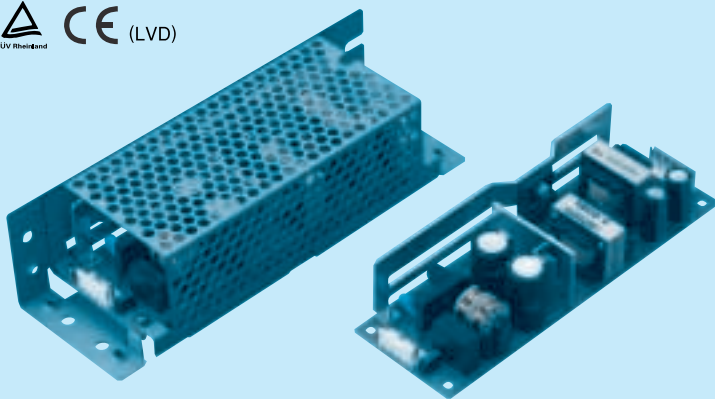

**Recommended Noise Filter  
NAC-06-472**



High voltage pulse noise type : NAP series  
Low leakage current type : NAM series  
\*The Noise Filter is recommended to connect with several devices.

- ① Series name
- ② Single output
- ③ Output wattage
- ④ 100/120V input
- ⑤ Output voltage
- ⑥ Optional
- C :with Coating
- G :Low leakage current
- H :with the function to be acceptable to output peak current (only 24V)
- J1 :VH(J.S.T.)connector type
- S :with Chassis
- SN:with Chassis & cover
- Y :with Potentiometer

This power supply is manufactured by SMD technology.The stress to P.C.B like twisting or bending causes the defect of the unit,so handle the unit with care.

MODEL	LGA75A-5	LGA75A-12	LGA75A-24	LGA75A-24-H
MAX OUTPUT WATTAGE[W]	75	75.6	76.8	76.8
DC OUTPUT	5V 15A	12V 6.3A	24V 3.2A	24V 3.2 (Peak 4.2) A

## SPECIFICATIONS

	MODEL	LGA75A-5	LGA75A-12	LGA75A-24	LGA75A-24-H	
INPUT	VOLTAGE[V]	AC85 - 132 1 φ (Refer to Instruction Manual 1.1, and 3.2 Derating)				
	CURRENT[A]	ACIN 100V	1.7typ (Io=100%)			
	FREQUENCY[Hz]	47 - 440 (Refer to Instruction Manual 1.1)				
	EFFICIENCY[%]	ACIN 100V	79.0typ (Io=100%)	83.0typ (Io=100%)	86.0typ (Io=100%)	86.0typ (Io=100%)
	INRUSH CURRENT[A]	ACIN 100V	30typ (Io=100%), (At cold start), (Ta= 25°C)			
	LEAKAGE CURRENT[ma]	0.5max (ACIN 100V, 60Hz, Io=100%, According to IEC60950-1 and DEN-AN)				
OUTPUT	VOLTAGE[V]	5	12	24	24	
	CURRENT[A]	*3 15.0	6.3	3.2	3.2 (Peak 4.2)	
	LINE REGULATION[mV]	20max	48max	96max	96max	
	LOAD REGULATION[mV]	40max	100max	150max	150max	
	RIPPLE[mVp-p]	0 to +50°C *1	80max	120max	120max	240max
		-10 - 0°C *1	140max	160max	160max	320max
	RIPPLE NOISE[mVp-p]	0 to +50°C *1	120max	150max	150max	300max
		-10 - 0°C *1	160max	180max	180max	360max
	TEMPERATURE REGULATION[mV]	0 to +50°C	50max	120max	240max	240max
		-10 to +50°C	60max	150max	290max	290max
	DRIFT[mV]	*2 20max	48max	96max	96max	
START-UP TIME[ms]	200max (ACIN 100V, Io=100%)					
HOLD-UP TIME[ms]	20typ (ACIN 100V, Io=100%)					
OUTPUT VOLTAGE ADJUSTMENT RANGE[V]	Fixed ("Y"which can be adjusted the output is available as optional ± 10%)					
OUTPUT VOLTAGE SETTING[V]	4.90 - 5.30	11.50 - 12.50	23.00 - 25.00	23.00 - 25.00		
PROTECTION CIRCUIT AND OTHERS	OVERCURRENT PROTECTION	Works over 105% of rating (works over 101% of peak current at option -H) and recovers automatically				
	OVERVOLTAGE PROTECTION	5.75 - 7.00	13.80 - 16.80	27.60 - 35.00	27.60 - 35.00	
	OPERATING INDICATION	Not provided				
	REMOTE SENSING	Not provided				
ISOLATION	REMOTE ON/OFF	Not provided				
	INPUT-OUTPUT	AC2,000V 1minute. Cutoff current = 10mA, DC500V 50MΩ min (At Room Temperature)				
	INPUT-FG	AC2,000V 1minute. Cutoff current = 10mA, DC500V 50MΩ min (At Room Temperature)				
ENVIRONMENT	OUTPUT-FG	AC500V 1minute, Cutoff current = 25mA, DC500V 50MΩ min (At Room Temperature)				
	OPERATING TEMP.,HUMID.AND ALTITUDE	-10 to +60°C, 20 - 90%RH (Non condensing) (Refer to DERATING CURVE), 3,000m (10,000feet) max				
	STORAGE TEMP.,HUMID.AND ALTITUDE	-20 to +75°C, 20 - 90%RH (Non condensing), 9,000m (30,000feet) max				
	VIBRATION	10 - 55Hz, 19.6m/s <sup>2</sup> (2G), 3minutes period, 60minutes each along X, Y and Z axis				
SAFETY AND NOISE REGULATIONS	IMPACT	196.1m/s <sup>2</sup> (20G), 11ms, once each X, Y and Z axis				
	AGENCY APPROVALS	UL60950-1, C-UL (CSA60950-1), EN60950-1 Complies with DEN-AN				
	CE MARKING	Low Voltage Directive				
OTHERS	CONDUCTED NOISE	Complies with FCC-B, VCCI-B, CISPR-B, EN55011-B, EN55022-B				
	CASE SIZE/WEIGHT	50 x 34.5 x 150mm (W x H x D) / 200g max (without chassis and cover)				
	COOLING METHOD	Convection				

\*1 This is the value that measured on measuring board with capacitor of 22 μF at 150mm from output terminal. Measured by 20MHz oscilloscope or Ripple-Noise meter (Equivalent to KEISOKU-GIKEN: RM-103).

\*2 Drift is the change in DC output for an eight hour period after a half-hour warm-up at 25°C, with the input voltage held constant at the rated input/output.

\*3 Peak loading for 10sec.And Duty 35% max.or less is acceptable if the total wattage is less than the rated wattage. Refer to instruction Manual 5. In detail.

\* Avoid prolonged use under over - load.

\* Parallel operation with other model is not possible.

\* Derating is required when operated with chassis and cover.

\* A sound may occur from power supply at pulse loading.

## Block diagram

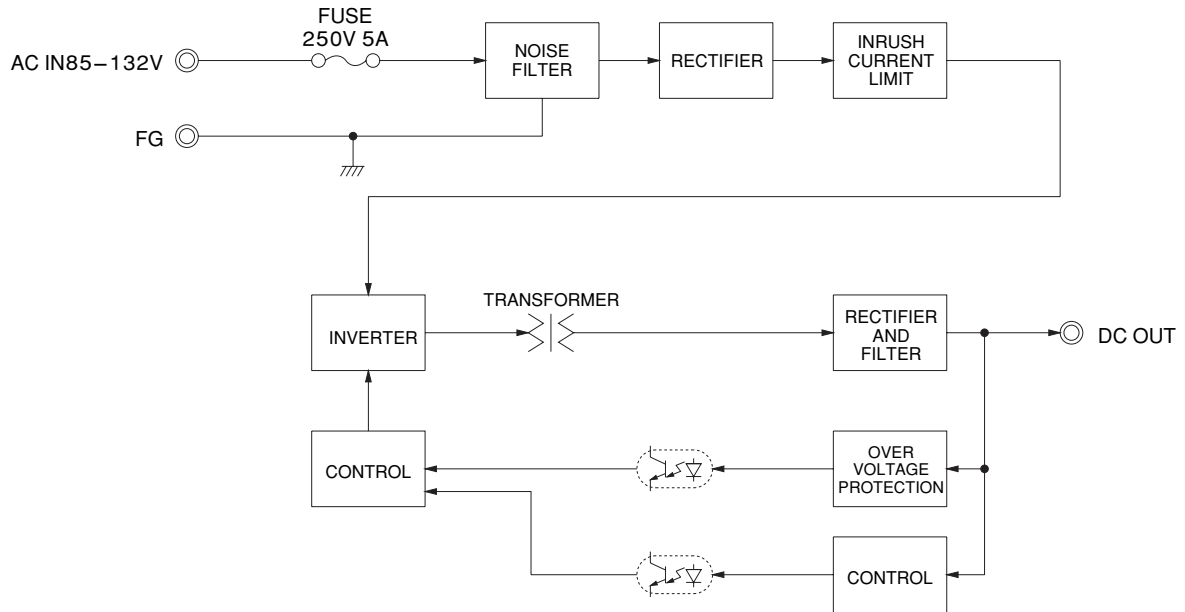

## External view

LGA

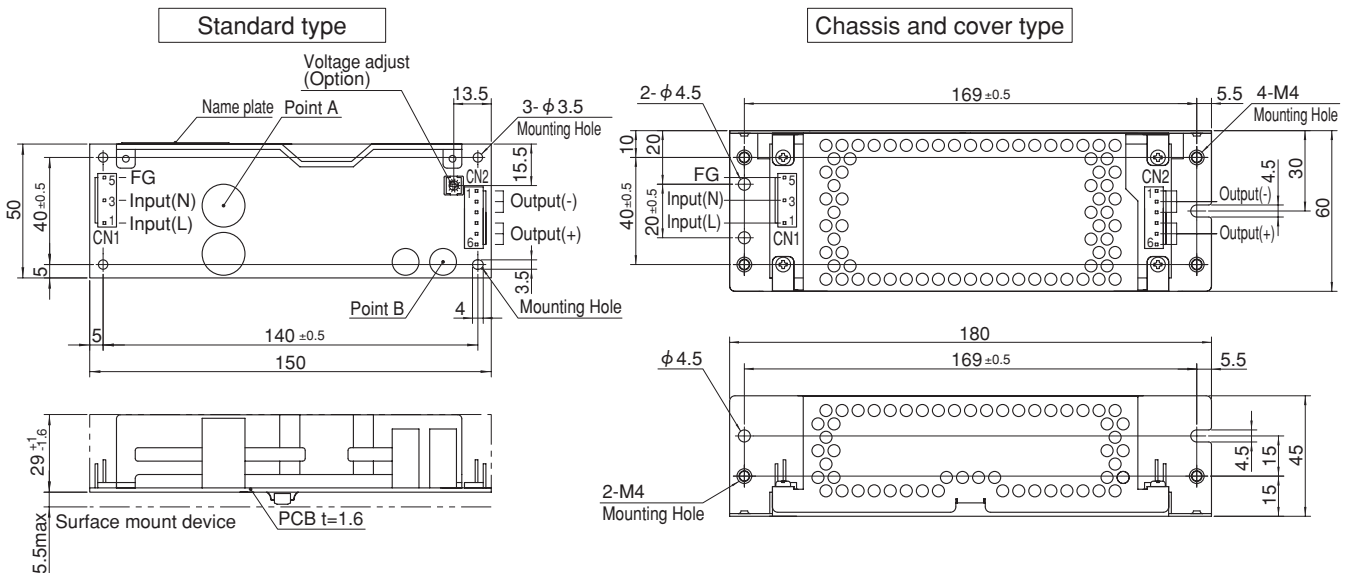

※ This power supply is manufactured by SMD technology. The stress to P.C.B like twisting or bending causes the defect of the unit, so handle the unit with care. Take care for SMD parts on the back to come in contact because of the vibration and not to break down.

※ Use the spacer of 8mm length or more.

※ 4 Mounting holes are existing.

I/O Connector	Mating connector	Terminal
CN1	1-1123724-3	Chain 1123721-1
		Loose 1318912-1
CN2	1-1123723-6	Chain 1123721-1
		Loose 1318912-1

(Mfr: Tyco Electronics AMP)

※ I/O Connector is Mfr Tyco Electronics AMP

※ Option: -J1:VH(J.S.T) connector type. Refer to instruction Manual 5.

### <PIN CONNECTION>

CN1		CN2	
Pin No.	Input	Pin No.	Output
1	AC(L)	1 to 3	-V
2			
3	AC(N)	4 to 6	+V
4			
5	FG		

※ Keep drawing current per pin below 5A for CN2.

※ Mounting torque: 1.5N·m(16kgf·cm)max

※ Tolerance: ±1

※ Weight: 200g max (without chassis and cover)

※ PCB material / thickness: CEM3 / 1.6mm

※ Optional chassis and cover material: Electric galvanizing steel board.

※ Dimensions is mm

# LGA100A

LG A 100 A -5 -□

① ② ③ ④ ⑤ ⑥

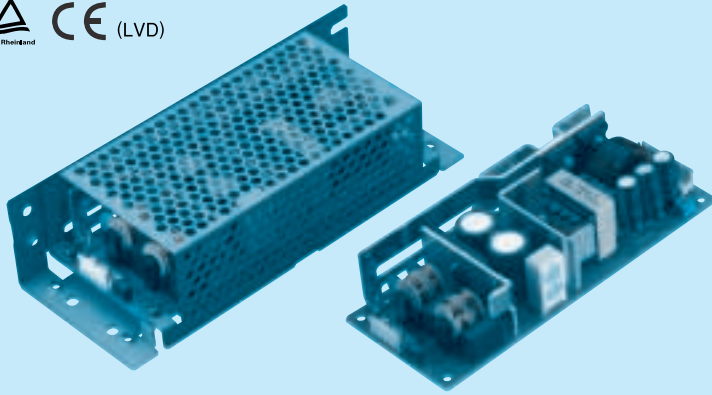

**Recommended Noise Filter  
NAC-06-472**



High voltage pulse noise type : NAP series  
Low leakage current type : NAM series  
\*The Noise Filter is recommended to connect with several devices.

- ① Series name
- ② Single output
- ③ Output wattage
- ④ 100/120V input
- ⑤ Output voltage
- ⑥ Optional
- C :with Coating
- G :Low leakage current
- H :with the function to be acceptable to output peak current (only 24V)
- J1 :VH(J.S.T.)connector type
- S :with Chassis
- SN:with Chassis & cover
- Y :with Potentiometer

This power supply is manufactured by SMD technology.The stress to P.C.B like twisting or bending causes the defect of the unit,so handle the unit with care.

MODEL	LGA100A-5-Y	LGA100A-12	LGA100A-24	LGA100A-24-H
MAX OUTPUT WATTAGE[W]	100	102	103.2	103.2
DC OUTPUT	5V 20A	12V 8.5A	24V 4.3A	24V 4.3 (Peak 5.4) A

## SPECIFICATIONS

	MODEL	LGA100A-5-Y	LGA100A-12	LGA100A-24	LGA100A-24-H	
INPUT	VOLTAGE[V]	AC85 - 132 1 φ (Refer to Instruction Manual 1.1, and 3.2 Derating)				
	CURRENT[A]	ACIN 100V	2.4typ (Io=100%)			
	FREQUENCY[Hz]	47 - 440 (Refer to Instruction Manual 1.1)				
	EFFICIENCY[%]	ACIN 100V	80.0typ (Io=100%)	83.0typ (Io=100%)	85.5typ (Io=100%)	85.5typ (Io=100%)
	INRUSH CURRENT[A]	ACIN 100V	15typ (Io=100%, More than 10sec. to re-start)			
	LEAKAGE CURRENT[ma]	0.5max (ACIN 100V, 60Hz, Io=100%, According to IEC60950-1 and DEN-AN)				
OUTPUT	VOLTAGE[V]	5	12	24	24	
	CURRENT[A]	*3	20.0	8.5	4.3	4.3 (Peak 5.4)
	LINE REGULATION[mV]	20max				
	LOAD REGULATION[mV]	40max				
	RIPPLE[mVp-p]	0 to +50°C *1	80max	120max	120max	240max
		-10 - 0°C *1	140max	160max	160max	320max
	RIPPLE NOISE[mVp-p]	0 to +50°C *1	120max	150max	150max	300max
		-10 - 0°C *1	160max	180max	180max	360max
	TEMPERATURE REGULATION[mV]	0 to +50°C	50max	120max	240max	240max
		-10 to +50°C	60max	150max	290max	290max
	DRIFT[mV]	*2	20max	48max	96max	96max
START-UP TIME[ms]	200max (ACIN 100V, Io=100%)					
HOLD-UP TIME[ms]	20typ (ACIN 100V, Io=100%)					
OUTPUT VOLTAGE ADJUSTMENT RANGE[V]	4.5 - 5.5	Fixed ("Y"which can be adjusted the output is available as optional ±10%)				
OUTPUT VOLTAGE SETTING[V]	5.00 - 5.15	11.50 - 12.50	23.00 - 25.00	23.00 - 25.00		
PROTECTION CIRCUIT AND OTHERS	OVERCURRENT PROTECTION	Works over 105% of rating (works over 101% of peak current at option -H) and recovers automatically				
	OVERVOLTAGE PROTECTION	5.75 - 7.00	13.80 - 16.80	27.60 - 35.00	27.60 - 35.00	
	OPERATING INDICATION	Not provided				
	REMOTE SENSING	Not provided				
ISOLATION	REMOTE ON/OFF	Not provided				
	INPUT-OUTPUT	AC2,000V 1minute. Cutoff current = 10mA, DC500V 50MΩ min (At Room Temperature)				
	INPUT-FG	AC2,000V 1minute. Cutoff current = 10mA, DC500V 50MΩ min (At Room Temperature)				
ENVIRONMENT	OUTPUT-FG	AC500V 1minute, Cutoff current = 25mA, DC500V 50MΩ min (At Room Temperature)				
	OPERATING TEMP.,HUMID.AND ALTITUDE	-10 to +60°C, 20 - 90%RH (Non condensing) (Refer to DERATING CURVE), 3,000m (10,000feet) max				
	STORAGE TEMP.,HUMID.AND ALTITUDE	-20 to +75°C, 20 - 90%RH (Non condensing), 9,000m (30,000feet) max				
	VIBRATION	10 - 55Hz, 19.6m/s <sup>2</sup> (2G), 3minutes period, 60minutes each along X, Y and Z axis				
SAFETY AND NOISE REGULATIONS	IMPACT	196.1m/s <sup>2</sup> (20G), 11ms, once each X, Y and Z axis				
	AGENCY APPROVALS	UL60950-1, C-UL (CSA60950-1), EN60950-1 Complies with DEN-AN				
	CE MARKING	Low Voltage Directive				
OTHERS	CONDUCTED NOISE	Complies with FCC-B, VCCI-B, CISPR-B, EN55011-B, EN55022-B				
	CASE SIZE/WEIGHT	62 x 35.5 x 155mm (W x H x D) / 300g max (without chassis and cover)				
	COOLING METHOD	Convection				

\*1 This is the value that measured on measuring board with capacitor of 22 μF at 150mm from output terminal. Measured by 20MHz oscilloscope or Ripple-Noise meter (Equivalent to KEISOKU-GIKEN: RM-103).

\*2 Drift is the change in DC output for an eight hour period after a half-hour warm-up at 25°C, with the input voltage held constant at the rated input/output.

\*3 Peak loading for 10sec.And Duty 35% max.or less is acceptable if the total wattage is less than the rated wattage. Refer to instruction Manual 5. In detail.

\* Avoid prolonged use under over - load.

\* Parallel operation with other model is not possible.

\* Derating is required when operated with chassis and cover.

\* A sound may occur from power supply at pulse loading.

## Block diagram

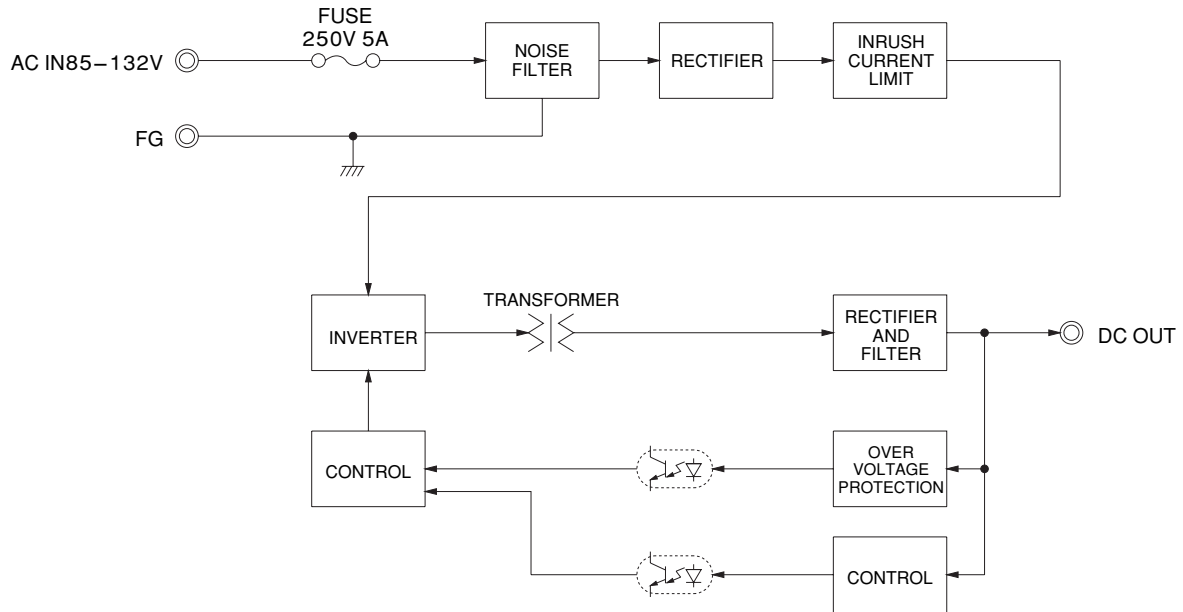

## External view

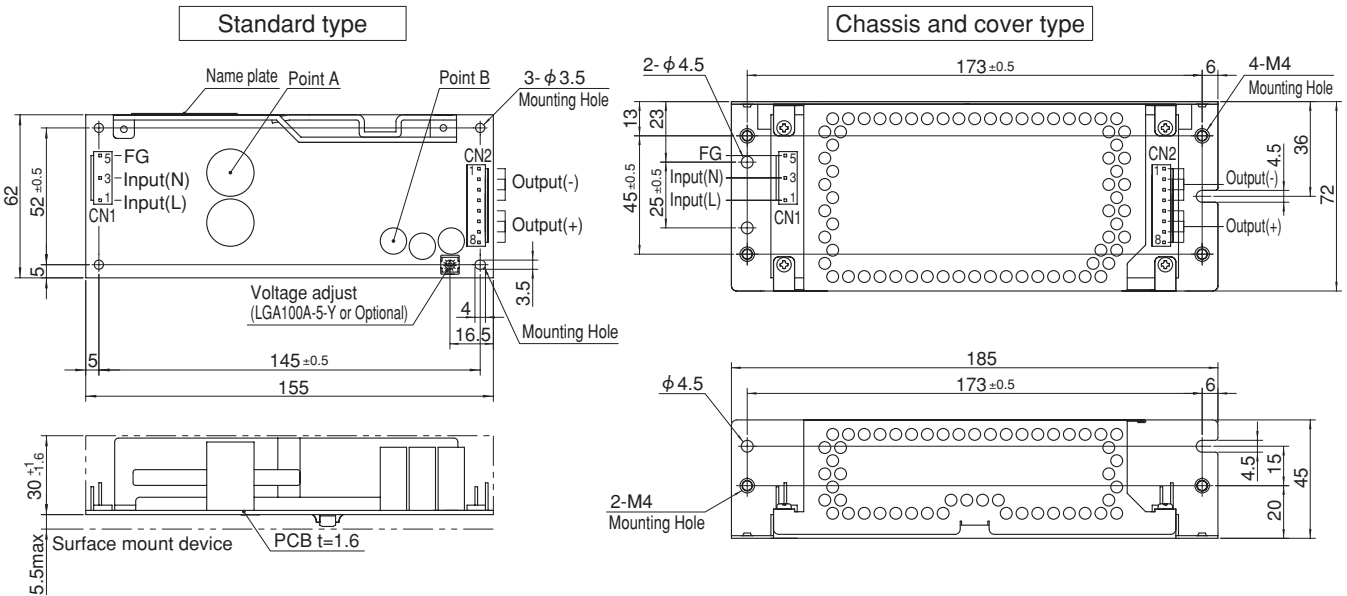

※ This power supply is manufactured by SMD technology.  
The stress to P.C.B like twisting or bending causes the defect of the unit, so handle the unit with care.  
Take care for SMD parts on the back to come in contact because of the vibration and not to break down.

※ Use the spacer of 8mm length or more.  
※ 4 Mounting holes are existing.

I/O Connector	Mating connector	Terminal
CN1	1-1123724-3	Chain 1123721-1 Loose 1318912-1
CN2	1-1123723-8	Chain 1123721-1 Loose 1318912-1

(Mfr: Tyco Electronics AMP)

※ I/O Connector is Mfr Tyco Electronics AMP  
※ Option: J1: VH(J.S.T) connector type.  
Refer to instruction Manual 5.

### <PIN CONNECTION>

CN1		CN2	
Pin No.	Input	Pin No.	Output
1	AC(L)	1 to 4	-V
2		5 to 8	+V
3	AC(N)		
4			
5	FG		

※ Keep drawing current per pin below 5A for CN2.

※ Mounting torque: 1.5N·m(16kgf·cm)max

※ Tolerance: ±1  
 ※ Weight: 300g max (without chassis and cover)  
 ※ PCB material / thickness: CEM3 / 1.6mm  
 ※ Optional chassis and cover material: Electric galvanizing steel board.  
 ※ Dimensions is mm

# LGA150A

LG A 150 A -5 -□

① ② ③ ④ ⑤ ⑥

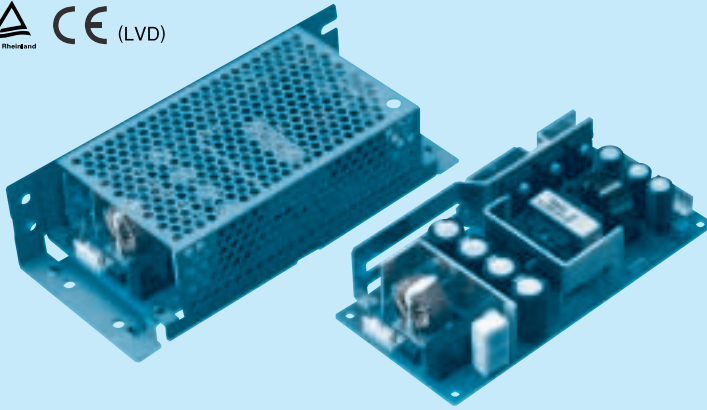

Recommended Noise Filter  
NAC-06-472



High voltage pulse noise type : NAP series  
Low leakage current type : NAM series  
\*The Noise Filter is recommended to connect with several devices.

- ① Series name
- ② Single output
- ③ Output wattage
- ④ 100/120V input
- ⑤ Output voltage
- ⑥ Optional
- C :with Coating
- G :Low leakage current
- H :with the function to be acceptable to output peak current (only 24V)
- J1 :VH(J.S.T.)connector type
- S :with Chassis
- SN:with Chassis & cover
- Y :with Potentiometer

This power supply is manufactured by SMD technology.The stress to P.C.B like twisting or bending causes the defect of the unit,so handle the unit with care.

MODEL	LGA150A-5-Y	LGA150A-12	LGA150A-24	LGA150A-24-H
MAX OUTPUT WATTAGE[W]	150	150	151.2	151.2
DC OUTPUT	5V 30A	12V 12.5A	24V 6.3A	24V 6.3 (Peak 7.9) A

## SPECIFICATIONS

	MODEL	LGA150A-5-Y	LGA150A-12	LGA150A-24	LGA150A-24-H	
INPUT	VOLTAGE[V]	AC85 - 132 1 φ (Refer to Instruction Manual 1.1, and 3.2 Derating)				
	CURRENT[A]	ACIN 100V	3.6typ (Io=100%)			
	FREQUENCY[Hz]	47 - 440 (Refer to Instruction Manual 1.1)				
	EFFICIENCY[%]	ACIN 100V	82.0typ (Io=100%)	84.5typ (Io=100%)	87.0typ (Io=100%)	87.0typ (Io=100%)
	INRUSH CURRENT[A]	ACIN 100V	15 /15 typ (Primary / Secondary Surge Current, Io=100%, More than 10sec. to re-start)			
	LEAKAGE CURRENT[ma]	0.5max (ACIN 100V, 60Hz, Io=100%, According to IEC60950-1 and DEN-AN)				
OUTPUT	VOLTAGE[V]	5	12	24	24	
	CURRENT[A]	*3	30.0	12.5	6.3	6.3 (Peak 7.9)
	LINE REGULATION[mV]	20max				
	LOAD REGULATION[mV]	40max				
	RIPPLE[mVp-p]	0 to +40°C *1	80max	120max	120max	240max
		-10 - 0°C *1	140max	160max	160max	320max
	RIPPLE NOISE[mVp-p]	0 to +40°C *1	120max	150max	150max	300max
		-10 - 0°C *1	160max	180max	180max	360max
	TEMPERATURE REGULATION[mV]	0 to +40°C	50max	120max	240max	240max
		-10 to +40°C	60max	150max	290max	290max
	DRIFT[mV]	*2	20max	48max	96max	96max
START-UP TIME[ms]	200max (ACIN 100V, Io=100%)					
HOLD-UP TIME[ms]	20typ (ACIN 100V, Io=100%)					
OUTPUT VOLTAGE ADJUSTMENT RANGE[V]	4.5 - 5.5	Fixed ("Y"which can be adjusted the output is available as optional ±10%)				
OUTPUT VOLTAGE SETTING[V]	5.00 - 5.15	11.50 - 12.50	23.00 - 25.00	23.00 - 25.00		
PROTECTION CIRCUIT AND OTHERS	OVERCURRENT PROTECTION	Works over 105% of rating (works over 101% of peak current at option -H) and recovers automatically				
	OVERVOLTAGE PROTECTION	5.75 - 7.00	13.80 - 16.80	27.60 - 35.00	27.60 - 35.00	
	OPERATING INDICATION	Not provided				
	REMOTE SENSING	Not provided				
ISOLATION	REMOTE ON/OFF	Not provided				
	INPUT-OUTPUT	AC2,000V 1minute. Cutoff current = 10mA, DC500V 50MΩ min (At Room Temperature)				
	INPUT-FG	AC2,000V 1minute. Cutoff current = 10mA, DC500V 50MΩ min (At Room Temperature)				
ENVIRONMENT	OUTPUT-FG	AC500V 1minute. Cutoff current = 25mA, DC500V 50MΩ min (At Room Temperature)				
	OPERATING TEMP.,HUMID.AND ALTITUDE	-10 to +60°C, 20 - 90%RH (Non condensing) (Refer to DERATING CURVE), 3,000m (10,000feet) max				
	STORAGE TEMP.,HUMID.AND ALTITUDE	-20 to +75°C, 20 - 90%RH (Non condensing), 9,000m (30,000feet) max				
	VIBRATION	10 - 55Hz, 19.6m/s <sup>2</sup> (2G), 3minutes period, 60minutes each along X, Y and Z axis				
SAFETY AND NOISE REGULATIONS	IMPACT	196.1m/s <sup>2</sup> (20G), 11ms, once each X, Y and Z axis				
	AGENCY APPROVALS	UL60950-1, C-UL (CSA60950-1), EN60950-1 Complies with DEN-AN				
	CE MARKING	Low Voltage Directive				
OTHERS	CONDUCTED NOISE	Complies with FCC-B, VCCI-B, CISPR-B, EN55011-B, EN55022-B				
	CASE SIZE/WEIGHT	75 x 39 x 160mm (W x H x D) / 420g max (without chassis and cover)				
	COOLING METHOD	Convection				

\*1 This is the value that measured on measuring board with capacitor of 22 μF at 150mm from output terminal. Measured by 20MHz oscilloscope or Ripple-Noise meter (Equivalent to KEISOKU-GIKEN: RM-103).

\*2 Drift is the change in DC output for an eight hour period after a half-hour warm-up at 25°C, with the input voltage held constant at the rated input/output.

\*3 Peak loading for 10sec.And Duty 35% max.or less is acceptable if the total wattage is less than the rated wattage. Refer to instruction Manual 5. In detail.

\* Avoid prolonged use under over - load.

\* Parallel operation with other model is not possible.

\* Derating is required when operated with chassis and cover.

\* A sound may occur from power supply at pulse loading.

## Block diagram

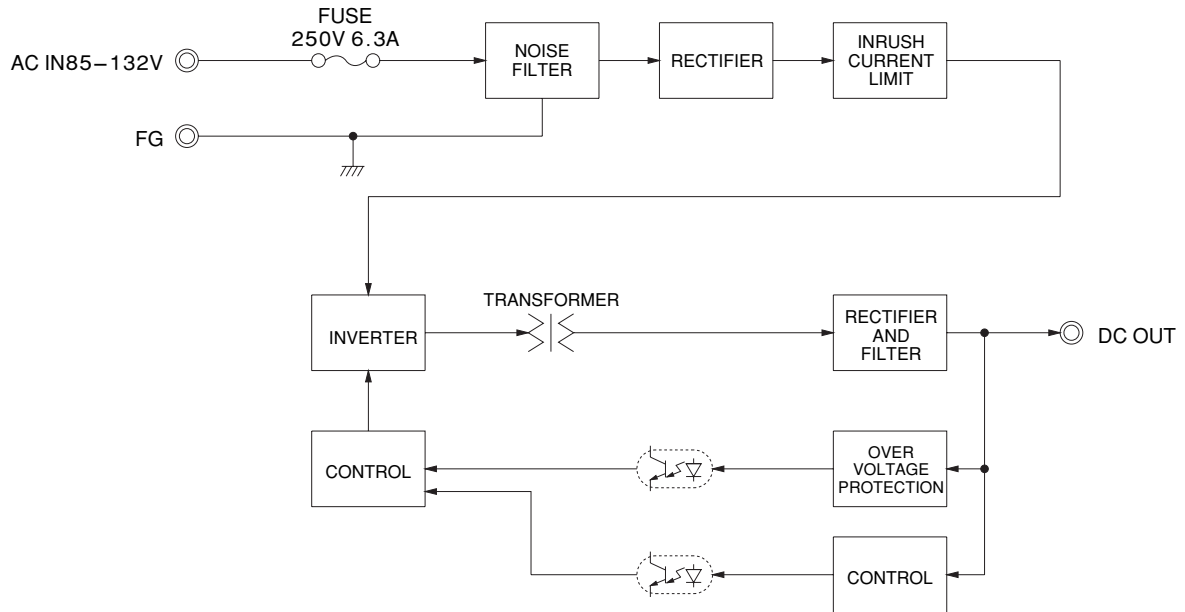

## External view

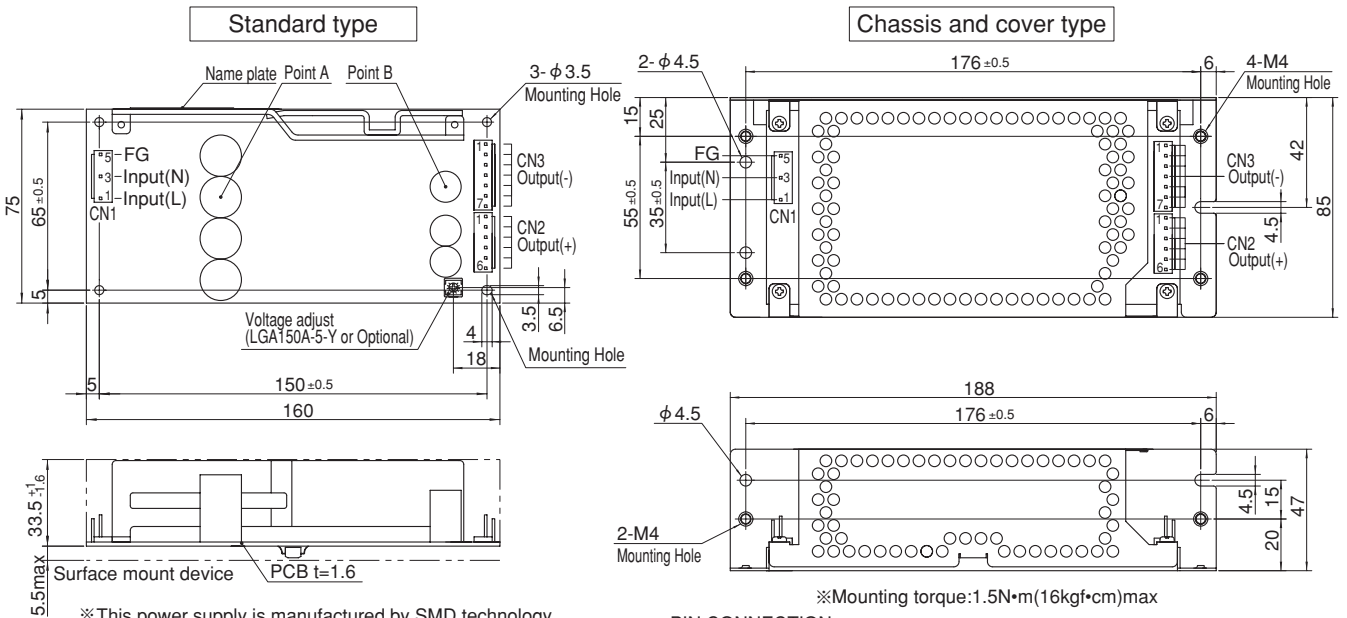

- ※ This power supply is manufactured by SMD technology. The stress to P.C.B like twisting or bending causes the defect of the unit, so handle the unit with care. Take care for SMD parts on the back to come in contact because of the vibration and not to break down.
- ※ Use the spacer of 8mm length or more.
- ※ 4 Mounting holes are existing.

I/O Connector	Mating connector	Terminal	
CN1	1-1123724-3	1-1123722-5	Chain 1123721-1
			Loose 1318912-1
CN2	1-1123723-6	1-1123722-6	Chain 1123721-1
			Loose 1318912-1
CN3	1-1123723-7	1-1123722-7	Chain 1123721-1
			Loose 1318912-1

(Mfr: Tyco Electronics AMP)

- ※ I/O Connector is Mfr Tyco Electronics AMP
- ※ Option: -J1: VH(J.S.T) connector type. Refer to instruction Manual 5.

※ Mounting torque: 1.5N•m(16kgf•cm)max  
 <PIN CONNECTION>

CN1		CN2		CN3	
Pin No.	Input	Pin No.	Output	Pin No.	Output
1	AC(L)	1 to 6	+V	1 to 7	-V
2					
3	AC(N)				
4					
5	FG				

※ Keep drawing current per pin below 5A for CN2, CN3.

- ※ Tolerance: ±1
- ※ Weight: 420g max (without chassis and cover)
- ※ PCB material / thickness: CEM3 / 1.6mm
- ※ Optional chassis and cover material: Electric galvanizing steel board.
- ※ Dimensions is mm

# LGA240A

LG A 240 A -5 -□

① ② ③ ④ ⑤ ⑥

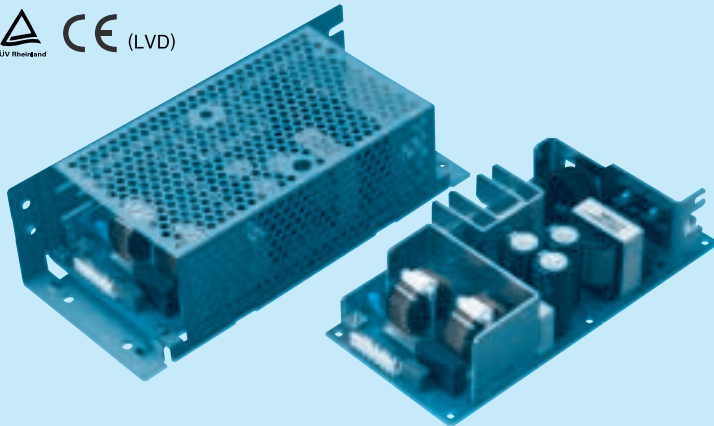

Recommended Noise Filter  
NAC-16-472



High voltage pulse noise type : NAP series  
Low leakage current type : NAM series  
\*The Noise Filter is recommended to connect with several devices.

- ① Series name
- ② Single output
- ③ Output wattage
- ④ 100/120V input
- ⑤ Output voltage
- ⑥ Optional
- C :with Coating
- G :Low leakage current
- H :with the function to be acceptable to output peak current (only 24V)
- J1 :VH(J.S.T.)connector type
- S :with Chassis
- SN:with Chassis & cover
- Y :with Potentiometer

This power supply is manufactured by SMD technology.The stress to P.C.B like twisting or bending causes the defect of the unit,so handle the unit with care.

MODEL	LGA240A-24	LGA240A-24-H
MAX OUTPUT WATTAGE[W]	240	240
DC OUTPUT	24V 10A	24V 10 (Peak 12.5) A

## SPECIFICATIONS

	MODEL	LGA240A-24	LGA240A-24-H	
INPUT	VOLTAGE[V]	AC85 - 132 1 φ (Refer to Instruction Manual 1.1, and 3.2 Derating)		
	CURRENT[A]	ACIN 100V	5.0typ (Io=100%)	
	FREQUENCY[Hz]	47 - 440 (Refer to Instruction Manual 1.1)		
	EFFICIENCY[%]	ACIN 100V	86.5typ (Io=100%)	
	INRUSH CURRENT[A]	ACIN 100V	15 / 20 typ (Primary / Secondary Surge Current, Io=100%, More than 10sec. to re-start)	
	LEAKAGE CURRENT[ma]	0.5max (ACIN 100V, 60Hz, Io=100%, According to IEC60950-1 and DEN-AN)		
OUTPUT	VOLTAGE[V]	24	24	
	CURRENT[A]	*3	10.0	
	LINE REGULATION[mV]	96max		
	LOAD REGULATION[mV]	150max		
	RIPPLE[mVp-p]	0 to +40°C *1	120max	240max
		-10 - 0°C *1	160max	320max
	RIPPLE NOISE[mVp-p]	0 to +40°C *1	150max	300max
		-10 - 0°C *1	180max	360max
	TEMPERATURE REGULATION[mV]	0 to +40°C	240max	240max
		-10 to +40°C	290max	290max
	DRIFT[mV]	*2	96max	96max
	START-UP TIME[ms]	200max (ACIN 100V, Io=100%)		
HOLD-UP TIME[ms]	20typ (ACIN 100V, Io=100%)			
OUTPUT VOLTAGE ADJUSTMENT RANGE[V]	Fixed ("Y"which can be adjusted the output is available as optional ± 10%)			
OUTPUT VOLTAGE SETTING[V]	23.00 - 25.00			
PROTECTION CIRCUIT AND OTHERS	OVERCURRENT PROTECTION	Works over 105% of rating (works over 101% of peak current at option -H) and recovers automatically		
	OVERVOLTAGE PROTECTION	27.60 - 35.00	27.60 - 35.00	
	OPERATING INDICATION	Not provided		
	REMOTE SENSING	Not provided		
	REMOTE ON/OFF	Not provided		
ISOLATION	INPUT-OUTPUT	AC2,000V 1minute. Cutoff current = 10mA, DC500V 50MΩ min (At Room Temperature)		
	INPUT-FG	AC2,000V 1minute. Cutoff current = 10mA, DC500V 50MΩ min (At Room Temperature)		
	OUTPUT-FG	AC500V 1minute, Cutoff current = 25mA, DC500V 50MΩ min (At Room Temperature)		
ENVIRONMENT	OPERATING TEMP.,HUMID.AND ALTITUDE	-10 to +60°C, 20 - 90%RH (Non condensing) (Refer to DERATING CURVE), 3,000m (10,000feet) max		
	STORAGE TEMP.,HUMID.AND ALTITUDE	-20 to +75°C, 20 - 90%RH (Non condensing), 9,000m (30,000feet) max		
	VIBRATION	10 - 55Hz, 19.6m/s <sup>2</sup> (2G), 3minutes period, 60minutes each along X, Y and Z axis		
	IMPACT	196.1m/s <sup>2</sup> (20G), 11ms, once each X, Y and Z axis		
SAFETY AND NOISE REGULATIONS	AGENCY APPROVALS	UL60950-1, C-UL (CSA60950-1), EN60950-1 Complies with DEN-AN		
	CE MARKING	Low Voltage Directive		
	CONDUCTED NOISE	Complies with FCC-B, VCCI-B, CISPR-B, EN55011-B, EN55022-B		
OTHERS	CASE SIZE/WEIGHT	84 x 48.5 x 180mm (W x H x D) / 590g max (without chassis and cover)		
	COOLING METHOD	Convection		

\*1 This is the value that measured on measuring board with capacitor of 22 μF at 150mm from output terminal. Measured by 20MHz oscilloscope or Ripple-Noise meter (Equivalent to KEISOKU-GIKEN: RM-103).

\*2 Drift is the change in DC output for an eight hour period after a half-hour warm-up at 25°C, with the input voltage held constant at the rated input/output.

\*3 Peak loading for 10sec.And Duty 35% max.or less is acceptable if the total wattage is less than the rated wattage. Refer to instruction Manual 5. In detail.

\* Avoid prolonged use under over - load.

\* Parallel operation with other model is not possible.

\* Derating is required when operated with chassis and cover.

\* A sound may occur from power supply at pulse loading.

## Block diagram

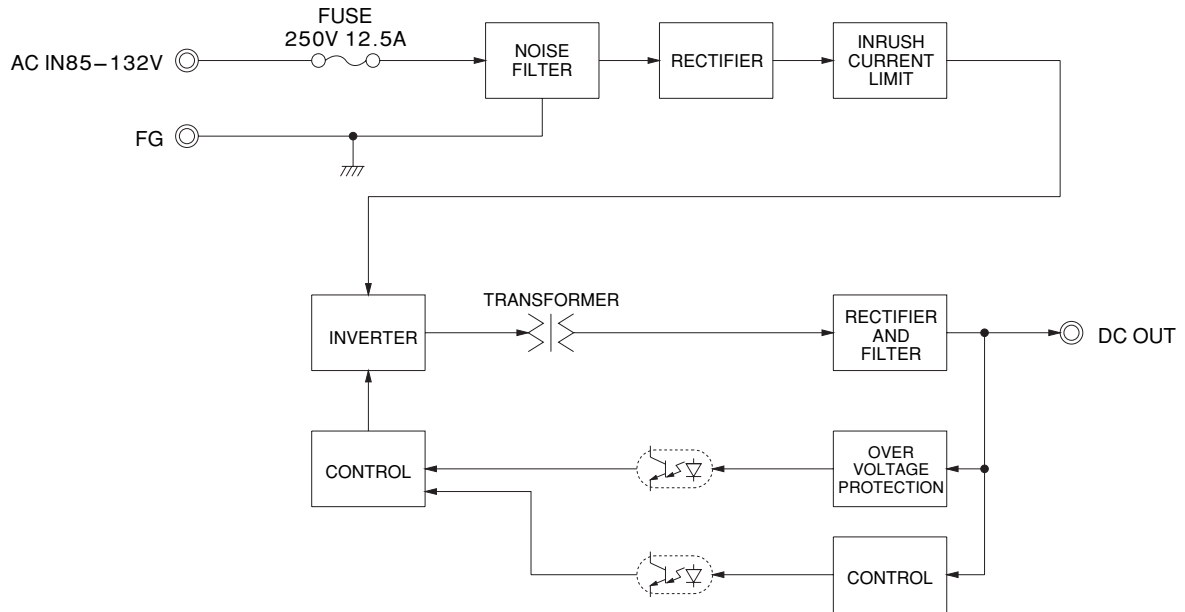

## External view

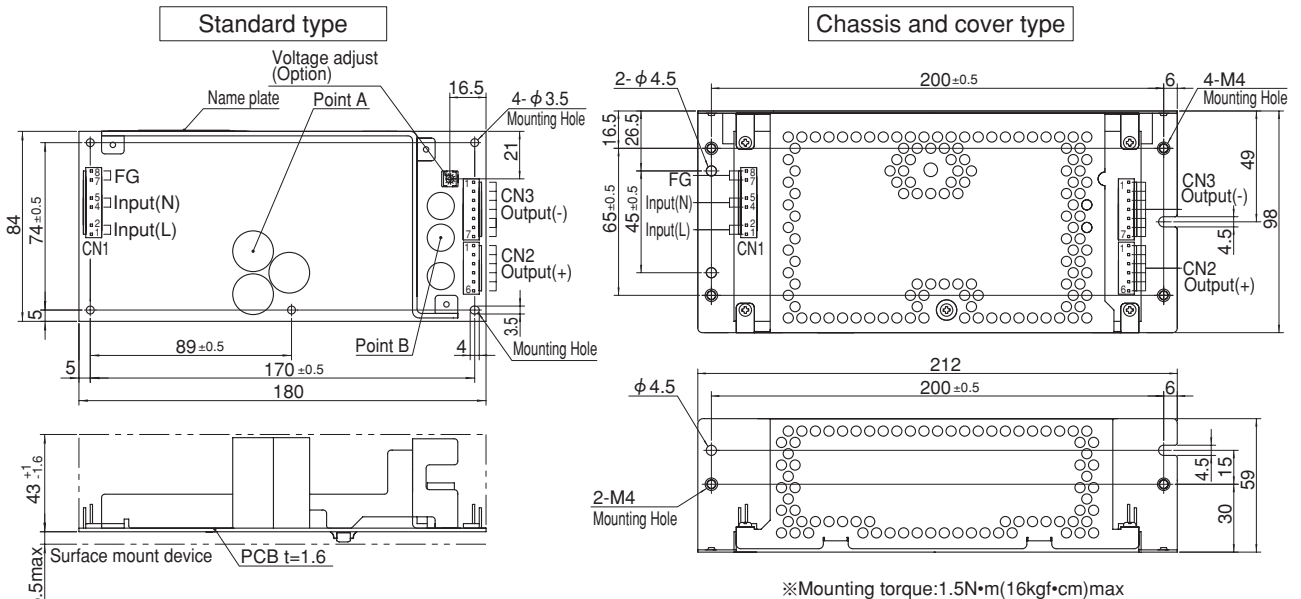

- ※ This power supply is manufactured by SMD technology. The stress to P.C.B like twisting or bending causes the defect of the unit, so handle the unit with care. Take care for SMD parts on the back to come in contact because of the vibration and not to break down.
- ※ Use the spacer of 8mm length or more.
- ※ 5 Mounting holes are existing.

I/O Connector	Mating connector	Terminal	
CN1	7-1565036-6	1-1123722-8	Chain 1123721-1
			Loose 1318912-1
CN2	1-1123723-6	1-1123722-6	Chain 1123721-1
			Loose 1318912-1
CN3	1-1123723-7	1-1123722-7	Chain 1123721-1
			Loose 1318912-1

(Mfr: Tyco Electronics AMP)

- ※ I/O Connector is Mfr Tyco Electronics AMP
- ※ Option: -J1: VH(J.S.T) connector type. Refer to instruction Manual 5.

※ Mounting torque: 1.5N·m (16kgf·cm) max

### <PIN CONNECTION>

CN1		CN2		CN3	
Pin No.	Input	Pin No.	Output	Pin No.	Output
1, 2	AC(L)	1 to 6	+V	1 to 7	-V
3					
4, 5	AC(N)				
6					
7, 8	FG				

※ Keep drawing current per pin below 5A for CN1, CN2 and CN3.

- ※ Tolerance: ±1
- ※ Weight: 590g max (without chassis and cover)
- ※ PCB material / thickness: CEM3 / 1.6mm
- ※ Optional chassis and cover material: Electric galvanizing steel board.
- ※ Dimensions is mm