

## Basic Characteristics Data

Model	Circuit method	Switching frequency [kHz]	Input current [A]	Rated input fuse	Inrush current protection	PCB/Pattern			Series/Parallel operation availability	
						Material	Single sided	Double sided	Series operation	Parallel operation
STA5000T	Rectification and filters		15	250V 30A	SCR	FR-4		Yes	No	No
STA5000T-R										

**1** Terminal Block STA-6**2** Function STA-6

- 2.1 Input voltage range ..... STA-6
- 2.2 Inrush current limiting ..... STA-6
- 2.3 Overcurrent protection ..... STA-6
- 2.4 Isolation ..... STA-6
- 2.5 Thermal protection ..... STA-6
- 2.6 Alarms ..... STA-6
- 2.7 Remote ON/OFF output ..... STA-6

**3** Assembling and installation Method STA-7

- 3.1 Cooling ..... STA-7
- 3.2 Mounting screw ..... STA-7

**4** Connecting the unit to a DBS series unit STA-7

- 4.1 Connection method ..... STA-7
- 4.2 Sequence unit ..... STA-7

# 1 Terminal Block

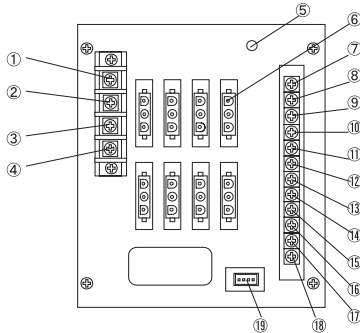

※ ⑦ - ⑱ are provided only in STA5000T-R

- |                   |  |
|-------------------|--|
| ①AC(R)            | ⑪REMOTE SIGNAL1 ON/OFF(+)                |
| ②AC(S)            | ⑫REMOTE SIGNAL1 ON/OFF(-)                |
| ③AC(T)            | ⑬REMOTE SIGNAL2 ON/OFF(+)                |
| ④Frame ground     | ⑭REMOTE SIGNAL2 ON/OFF(-)                |
| ⑤LED              | ⑮REMOTE SIGNAL3 ON/OFF(+)                |
| ⑥Output connector | ⑯REMOTE SIGNAL3 ON/OFF(-)                |
| ⑦ALM(+)           | ⑰REMOTE SIGNAL4 ON/OFF(+)                |
| ⑧ALM(-)           | ⑱REMOTE SIGNAL4 ON/OFF(-)                |
| ⑨SYSTEM ON/OFF(+) | ⑲SIGNAL(AL OUT, REMOTE ON/OFF) connector |
| ⑩SYSTEM ON/OFF(-) |  |

# 2 Function

## 2.1 Input voltage range

- The range is from AC175V to AC264V by 3 phase.  
AC input voltage must have a range from AC175V to AC264V for normal operation. If the wrong input is applied, the unit will not operate properly and/or may be damaged.
- In cases that conform with safety standard, input voltage range is AC200-AC240V(50/60Hz).

## 2.2 Inrush current limiting

- Inrush current limiting is built-in.  
If a switch on the input side is installed, it has to be the one handling the input inrush current.  
The thyristor technique is used for protection from inrush current. When power is turned ON/OFF repeatedly within a short period of time, it is necessary to have enough time between power ON and OFF to operate resistance circuit for inrush current.

## 2.3 Overcurrent protection

- The input fuse provides protection against overcurrent.  
This fuse blows when the output is short-circuited.  
Replace only with the same type of fuse.

## 2.4 Isolation

- For a receiving inspection, such as Hi-Pot test, gradually increase (decrease) the voltage for the start (shut down).  
Avoid using Hi-Pot tester with the timer because it may generate voltage a few times higher than the applied voltage, at ON/OFF of a timer.

## 2.5 Thermal protection

- A rise in the temperature of the power unit's interior (due to stoppage of the external fan, etc.) will trigger activation of the over-heating detection circuits.  
If these circuits are activated, shut off the input voltage and wait until the power unit's interior has thoroughly cooled before resuming the input to the power unit.

## 2.6 Alarms

- The power unit (STA5000T) has a built-in alarm signal outputting circuit for monitoring its operation. When this circuit works, the signal from the AL OUT (ALM for STA5000T-R) will change from L to H.  
The alarm signal is provided when the following situations arise:
  - 1) 1 of the 3 phases is missing, due to equipment failure, etc.
  - 2) Activation of the thermal detection.
 Note that the output voltage will not stop even when the alarm circuit works. Shut off the input, otherwise the power unit may be damaged.  
AL OUT signal (ALM signal for STA5000T-R) might be H level if voltage drop would happen when load is light.

## 2.7 Remote ON/OFF output

- The power unit has a built-in REMOTE ON/OFF circuit for controlling the DC-DC modules being used with it.  
If AC voltage is applied to the power unit, the signal from the REMOTE ON/OFF terminal will change from H to L after a few hundred milliseconds. Under the following situations, however, the signal from the REMOTE ON/OFF terminal will change from L to H:
  - 1) 1 of the 3 phases is missing, due to equipment failure, etc.
 REMOTE ON/OFF signal might be H level if voltage drop would happen when load is light.

### 3 Assembling and Installation Method

#### 3.1 Cooling

■The power unit is designed for use with forced cooling by external fans. When the power unit is used, the temperature of part A of the unit should be below 75 degree by flowing cooling-air inside of unit uniformly.

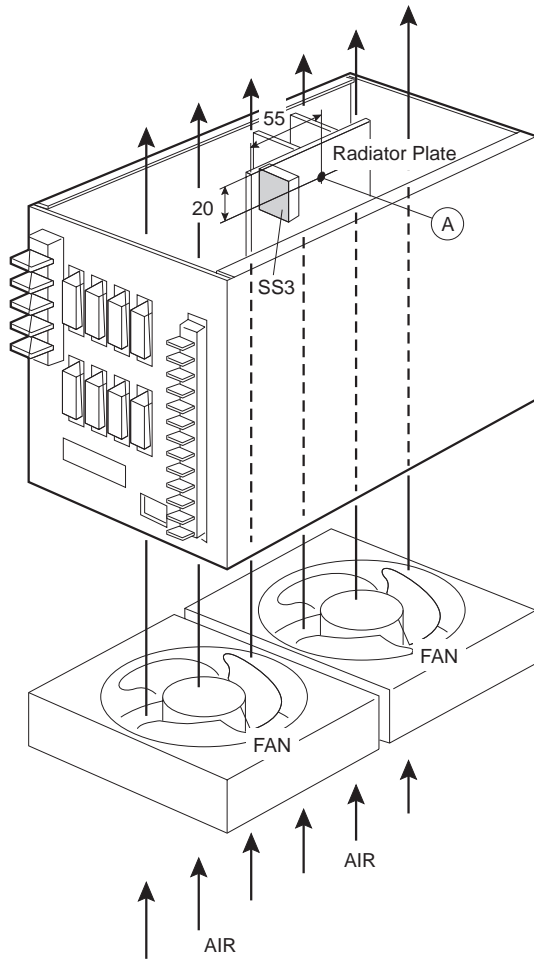

#### 3.2 Mounting screw

■Keep isolation distance between screw and internal components as below chart.

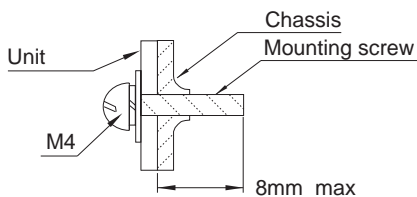

### 4 Connecting the unit to a DBS series unit

#### 4.1 Connection method

■Pay attention to these points when connecting a DBS series unit to the STA5000T.

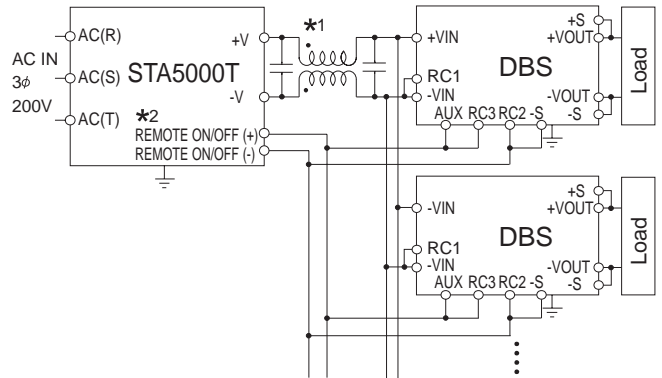

#### 4.2 Sequence unit

■STA5000T can optionally be equipped with a sequence unit for controlling the DBS series units' remote control circuits ON/OFF with a particular timing.

Employing this sequence unit enables starting and stopping of up to 4 DBS systems at differential times.

The sequence unit operates by shorting the SYSTEM ON/OFF terminals to change the status of the REMOTE SIGNAL 1 - 4 ON/OFF terminals from H to L.

Under the following situations, however, the signal from the REMOTE SIGNAL 1 - 4 ON/OFF terminals will change from L to H.

- 1) 1 of the 3 phases is missing, due to equipment failure, etc.
- 2) Activation of the thermal detection.

Power units equipped with a sequence unit have the model name "STA5000T-R".

REMOTE SIGNAL 1-4 signal might be H level if voltage drop would happen when load is light.

For detailed information on how to use the sequence unit, please consult our sales or engineering departments.

\*1 For some users, noise regulation requirements may make a EMI/EMC Filter necessary.

Users are recommended to install a EMI/EMC Filter to reduce radiation noise from the cabling, especially in cases where the cabling is long.

\*2 Be sure to connect up the REMOTE ON/OFF terminals (or the REMOTE SIGNAL ON/OFF terminals in a STA5000T-R) before running the DBS.

Using the DBS without those terminals connected could damage the STA5000T.