

## 1 Functions D-12

1.1	Input Voltage Range .....	D-12
1.2	Inrush Current Limiting .....	D-12
1.3	Overcurrent Protection .....	D-12
1.4	Overvoltage Protection .....	D-12
1.5	Low-voltage Protection .....	D-12
1.6	Thermal Protection .....	D-12
1.7	Output Voltage Adjustment .....	D-12
1.8	System ON/OFF .....	D-13
1.9	Remote Signal ON/OFF .....	D-13
1.10	Alarms .....	D-13
1.11	Parallel Control (Start in / out) .....	D-14
1.12	Sequence Diagram .....	D-14

## 2 Single / Parallel / Series Operation D-14

2.1	Single Operation .....	D-14
2.2	Parallel Operation .....	D-15
2.3	N+1 Parallel Redundancy Operation .....	D-16
2.4	Series Operation .....	D-16

## 3 Assembling and Installation D-17

3.1	Installation .....	D-17
3.2	Cooling Method .....	D-17
3.3	Expected Life .....	D-17
3.4	Warranty .....	D-17

## 4 Others D-18

4.1	Output Voltage Monitor .....	D-18
4.2	Output Current Monitor .....	D-18
4.3	External output voltage control function / Constant current regulation .....	D-18
4.4	Isolation .....	D-18
4.5	External Component (Noise Filter) .....	D-18

## 5 Options D-19

5.1	Outline of Options .....	D-19
-----	--------------------------	------

# 1 Functions

## 1.1 Input Voltage Range

- The input voltage range is AC160-264V (three-phase).
- In cases that conform with safety standard, input voltage range is AC180-AC240V (50/60Hz).
- In the case of three-phase four-wire system, connect the three wires to input terminal, except ground wire.
- If the wrong input or single phase input is applied, the unit will not operate properly and/or may be damaged.

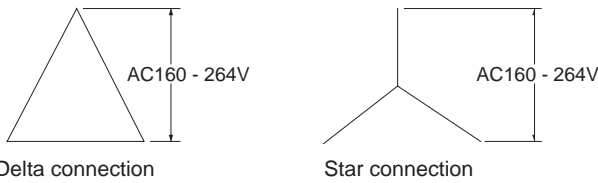

Fig.1.1 Connection method

## 1.2 Inrush Current Limiting

- An inrush current limiting circuit is built-in.
- If you need to use a switch on the input side, please select one that can withstand an input inrush current.
- Thyristor technique is used in the inrush current limiting circuit. When you turn the power ON/OFF repeatedly within a short period of time, please have enough intervals so that the inrush current limiting circuit becomes operative.
- When the switch of the input is turned on, the primary inrush current and secondary inrush current will be generated because the thyristor technique is used for the inrush current limiting circuit.

## 1.3 Overcurrent Protection

- An overcurrent protection circuit is built-in and activated at 105% - 120% of the rated current. A unit automatically recovers when a fault condition is removed. Please do not use a unit in short circuit and/or under an overcurrent condition.
- Low-voltage protection is activated when output voltage is reduced by over current protection under the low-voltage protection value.

## 1.4 Overvoltage Protection

- An overvoltage protection circuit is built-in. If the overvoltage protection circuit is activated, shut down the input voltage, wait more than 3 seconds and turn on the AC input again to recover the output voltage.

**Note :**

- Please avoid applying a voltage exceeding the rated voltage to an output terminal. Doing so may cause a power supply to malfunction or fail. If you cannot avoid doing so, for example, if you need

to operate a motor, etc., please install an external diode on the output terminal to protect the unit.

## 1.5 Low-voltage Protection

- Low-voltage protection is built-in. This protection will shut down the output with the activation. To restart the output, recycle AC input after 3 or more seconds.

## 1.6 Thermal Protection

- A thermal protection circuit is built-in. The thermal protection circuit may be activated under following conditions and shut down the output.
  - ① Continuous over current 208A or more.
  - ② Continuous over wattage 9984W or more.
  - ③ When the cooling which deviates from referred to 3.2 are consecutive.
  - ④ When a fan stops or air flow is blocked from the fan and weakens.

If the thermal protection circuit is activated, shut off the input voltage and eliminate all the overheating conditions. To recover the output voltage, have enough time to cool down the unit before turning on the input voltage again.

## 1.7 Output Voltage Adjustment

- To increase an output voltage, turn a built-in potentiometer clockwise. To decrease the output voltage, turn it counterclockwise.
- Output Voltage Adjustment is 43.2 - 52.8V.
- Output Voltage factory setting is 47.0 - 49.0V.

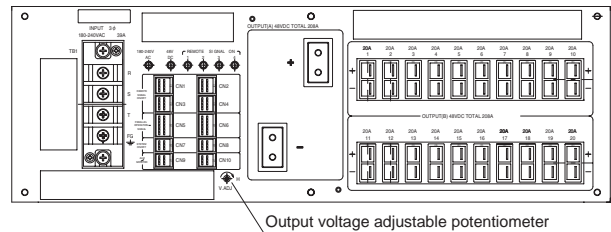

Fig.1.2 SCHA10000T Output voltage adjustable potentiometer

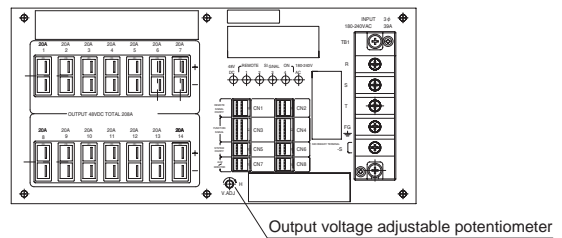

Fig.1.3 SCDA10000T Output voltage adjustable potentiometer

### 1.8 System ON/OFF

- System ON/OFF controls output voltage On/Off and Remote signal ON/OFF by open/short terminals (SCHA10000T : CN7,8 SCDA10000T : CN5,6).
- System ON/OFF specification is on Table1.1.
- A connection example is on Figure1.4. Connector locations and pin assignment are shown on the external view.
- System ON/OFF circuit is isolated from all of the others which are input, output, FG, Remote signal ON/OFF and Alarms.
- System ON/OFF sequence diagram is explained in 1.12.

Table1.1 Specifications of system ON/OFF

Output	System ON/OFF	Remote signal ON/OFF
ON	Short(Low) (Less than 1V, less than 5mA)	Low (0-0.5V, less than 1000mA)
OFF	Open(High) (Open voltage 2.5V-5.0V) (Absolute maximum rating 30V)	High or Open (Absolute maximum rating 30V)

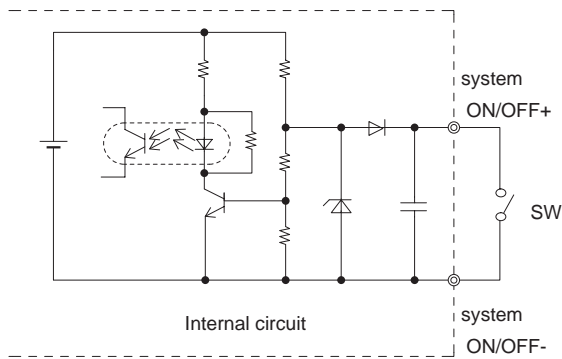

Fig.1.4 Example of System ON/OFF

### 1.9 Remote Signal ON/OFF

- Remote signal ON/OFF switches an external power supply ON/OFF such as DC/DC converter (SCHA10000T : CN1 - 4, SCDA10000T : CN1,2).
- The internal circuit is on Figure 1.5.
- Remote signal specification is on Table1.1.
- Connector locations and pin assignment are shown on the external view.
- The remote signal ON/OFF circuit is isolated from all of the others which are input, output, FG, System ON/OFF and Alarms.
- Remote signal ON/OFF sequence diagram is explained in 1.12.

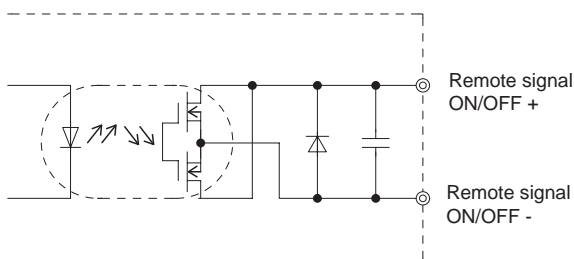

Fig.1.5 Internal circuit of Remote signal ON/OFF

### 1.10 Alarms

- The alarm signal detailed on Table1.2 is sent out from the alarm terminal (SCHA10000T : CN9,10 SCDA10000T : CN7,8). Pin assignment is shown on external view.
- Alarm specification is on Table1.3.
- The internal circuit is on Figure 1.6.
- Alarm diagram is explained in 1.12.

Table1.2 An alarm generated condition

An alarm generated condition
(1)Low input voltage (AC160V or less) or disconnection of one phase of three phase line.
(2)Thermal protection is activated and shuts down the output voltage.
(3)Decreased output voltage and the low-voltage protection is activated.
(4)Shut down output voltage and the low-voltage protection is activated.
(5)Overvoltage protection is activated and shuts down the output voltage.
(6)Over current protection is activated and decreases the output voltage.
(7)Turn off AC power source, then recycle AC within 3 seconds. This condition keeps off the output voltage with sending out the alarm.

Table1.3 Specifications of alarm

condition of power supply	Output of Alarm
good	Low (0-0.5V, less than 200mA)
bad	High or Open (Absolute maximum rating 30V)

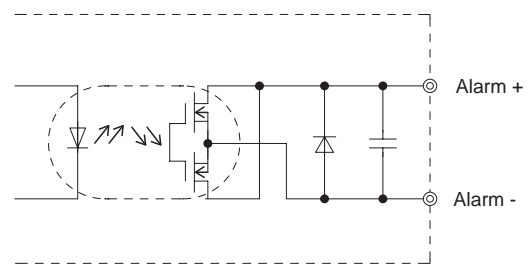

Fig.1.6 Internal circuit of Alarm

- Alarm circuit is isolated from input, output, FG, system ON/OFF and Remote signal ON/OFF.

SC

### 1.11 Parallel Control (Start in / out)

■By connecting PCNT pin, difference of start-up voltage and stop voltage can be prevented.

■Total number of units should be no more than 10 units.

### 1.12 Sequence Diagram

①System ON / OFF is Short (Low) before turning on AC.

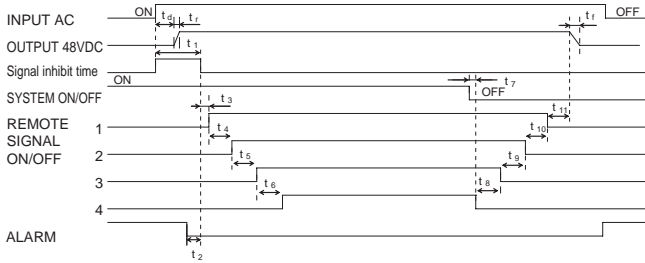

Fig.1.7 Timing diagram 1

②System ON / OFF is Short (Low) after turned on AC.

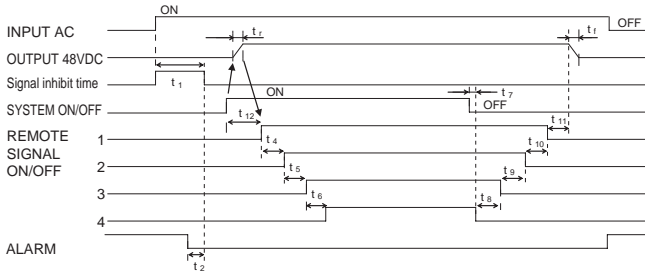

Fig.1.8 Timing diagram 2

③Abnormal condition

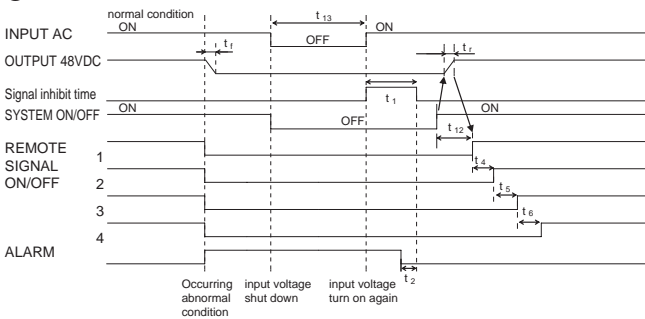

Fig.1.9 Timing diagram 3

$t_r$  : Rise time

30ms max (DC48V External Capacity is less than 50,000 $\mu$ F, at rated load)

70ms max (DC48V External Capacity is less than 150,000 $\mu$ F, at rated load)

$t_r+t_f$  : Start-up time 750ms max

$t_f$  : Fall time 500ms max (Load factor more than 10% )

$t_1$  Signal inhibit time : 0.75 - 1.15s

$t_2$  : 100ms min  $t_4-t_6, t_8-t_{11}$  : 0.6s $\pm$ 10%

$t_3, t_7, t_{12}$  : 100ms max  $t_{13}$  : 3s min

\* Remote signal ON/OFF sequence follows ① if System ON/OFF is turned Short (Low) during inhibit time.

\*  $t_{12}$  : 48V turns on within 100ms after turned Short (Low) System ON/OFF. Then the Remote signal ON/OFF 1 turns Low.

\* With shorted output condition, the output voltage will shut off and send out the alarm.

\* In parallel, both output are synchronized ON/OFF with PCNT connection between both.

## 2 Single / Parallel / Series Operation

### 2.1 Single Operation

#### ● SCHA1000T

■OUTPUT(A) and OUTPUT(B), both are able to draw output current up to 208 amps in total.

■Fuses are built-in, and connected to each connector as shown in Fig.2.2.

■OUTPUT(B) has 20 amps drawing capability per each connector.

■Internal output fuse may open with over current.

To repair the opened fuse, please return the unit to us with a Co-sel issued RMA.

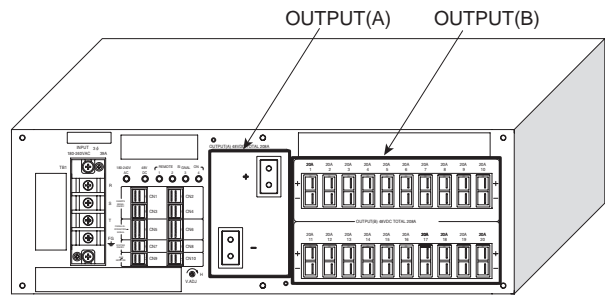

Fig.2.1 Output of SCHA1000T

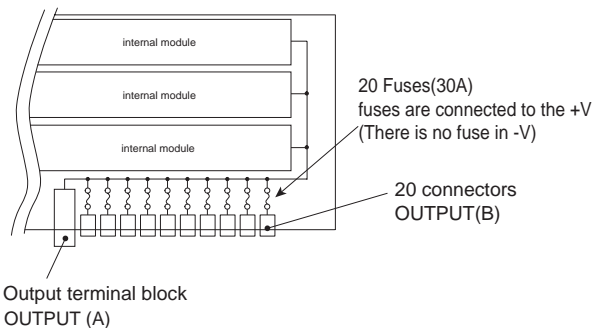

Fig.2.2 Output part block diagram

#### ● SCDA1000T

■Output connectors are able to draw output current up to 208 amps in total.

■Fuses are built-in, and connected to each connectors as shown in Fig.2.4.

■Output connectors has 20 amps drawing capability per each connector.

■Internal output fuse may open with over current.  
To repair the opened fuse, please return the unit to us with a Cosel issued RMA.

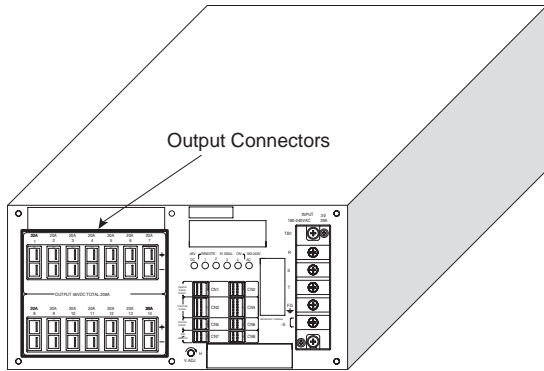

Fig.2.3 Output of SCDA10000T

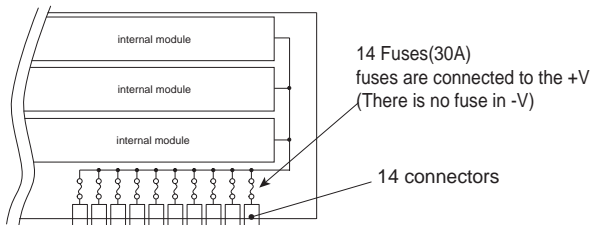

Fig.2.4 Output part block diagram

## 2.2 Parallel Operation

### ● SCDA10000T

- Parallel operation is up to 3 units as following Figure2.5.  
Each output terminal block [OUTPUT(A)] should be connected parallel and CTB/COM as well. MAS of the master unit and SLV of all slave units must be connected with H-PA-8, H-PA-7.
- Differences in the output current values among the power supplies in parallel connection are 5% at most. Please make sure that the sum of the output current values does not exceed a value obtained from the following equation.

(Output current in parallel operation)  

$$= (\text{Rated current per unit}) \times (\text{Number of units}) \times 0.95$$

- Each connector of OUTPUT(B) of each unit which is connected in parallel has 20 amps drawing capability.
- Internal output fuse may open with over current.  
To repair the opened fuse, please return the unit to us with Cosel issued RMA.
- Output voltage is adjustable by adjusting the master unit potentiometer (One control mode).
- Parallel connection with other products is not allowed.
- In case of use PCNT, all of power supplies will stop, if either of the power supply fail.

■In case of the parallel operated connection without the bus bar as shown in Fig.2.5, the difference of impedance of load wires of each unit and connectors causes difference of output current of each unit and connectors.  
Therefore, connection using the parallel bus bar as shown in Fig.2.5 is required to parallel operation.

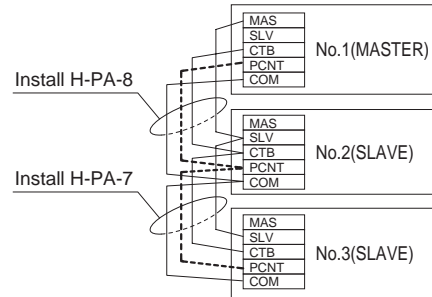

(a)Connection of signal

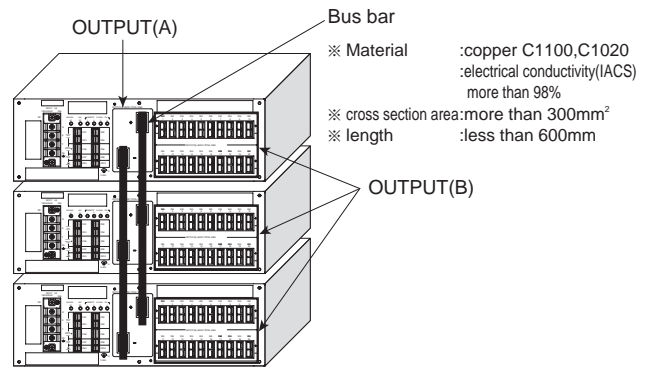

(b)Connection of bus bar

Fig.2.5 Example of parallel connection

### ● SCDA10000T

■Parallel operation is not possible.

## 2.3 N+1 Parallel Redundancy Operation

### ● SCHA10000T

■N+1 redundancy operation is possible by connecting units as shown in Fig.2.6. Each output voltage difference has to be adjusted within +/- 200mV before connecting both units. Output terminal block [OUTPUT(A)] has to be connected together, with bus bar. CTB and COM are also connected together between all units in parallel.

■Output current calculation is required based on following equation. The current has to be more over normal operation current even if one power supply fails.

$$\text{Maximum output current} \leq \text{Rated current per unit} \times \text{Numbers of normal operated units} \times 0.95$$

■Each connector of OUTPUT(B) of each unit which is connected in parallel has 20 amps drawing capability.

■Internal output fuse may open with over current.

To repair the opened fuse, please return the unit to us with Cosel issued RMA.

■Parallel with other products is not allowed.

■Please shut off the input voltage when you replace a failed power supply.

■Load disconnection and output voltage adjustment are required when a failed power supply is replaced. The voltage adjustment requirement is within +/-200mV between output voltage in parallel before connecting to the load.

■2 or more power supplies failures may cause the output voltage to decrease, lending the application system to shut down. Immediate replacement is recommended when a power supply has failed.

■Do not connect MAS/SLV and PCNT to any connector for N+1 redundancy operation.

■Master Slave operation is not available for N+1 redundancy operation (N/A one control mode operation), you have to adjust the output voltage before the output connection.

■In case of the parallel operated connection without the bus bar as shown in Fig.2.6, the difference of impedance of load wires of each unit and connectors causes difference of output current of each unit and connectors.

Therefore, connection using the parallel bus bar as shown in Fig.2.6 is required to parallel operation.

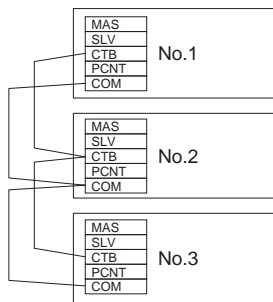

(a)Connection of signal

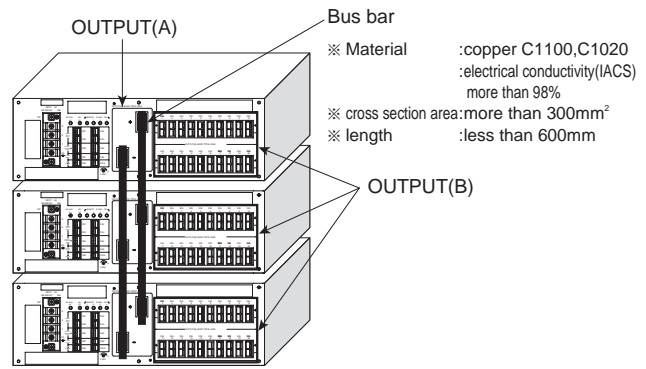

(b)Connection of bus bar

Fig.2.6 Example of N+1 redundancy operating connection

### ● SCDA10000T

■N+1 redundancy operation is not possible.

## 2.4 Series Operation

### ● SCHA10000T

■Series operation is available by connecting the outputs of two or more power supplies with the same output voltage, as shown below. Output current in series connection should be lower than the lowest rated current in each unit.

In case of series operation, it have to be connected OUTPUT(A)s each other.

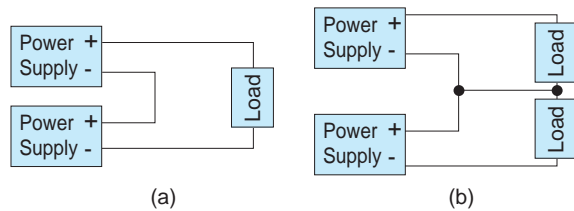

Fig.2.8 Examples of connecting in series operation

### ● SCDA10000T

■Series operation is not possible.

# 3 Assembling and Installation

## 3.1 Installation

- Screw mounting has to be consider the product weight for safety fixture.
- To keep enough insulation distance between screws and internal components, length of the mounting screw should not exceed recommendation as following Table3.1.

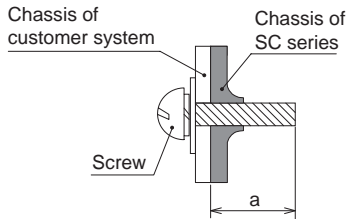

Table 3.1 Max penetration length

Mounting hole	Diameter	a (Max penetration length)
Chassis	M6	8mm max
	M5	7mm max
Output terminal block (SCHA10000T)	M5	10mm max
Safety cover (Bus bar) (SCHA10000T)	M3	7mm max

## 3.2 Cooling Method

This power supply unit is designed for assuming external cooling fans. Follow instruction of cooling condition as follows.

- Built into cooling air flow line in the system(Duct structure air cooling) for uniform cooling air flow.
- Number of stacked units is up to 3, as shown in Fig. 3.2 and Fig 3.3.
- Air flow direction is either Up or Down as shown in Fig. 3.2 and Fig 3.3.
- Clearance between stacked units is  $1.5\text{mm} \leq d \leq 6\text{mm}$ .
- Fig. 3.1 to Fig. 3.3 show the position of cooling fan units.
- Contact us for more information if your design utilizes other cooling methods.

### ① Cooling methods for use of single unit

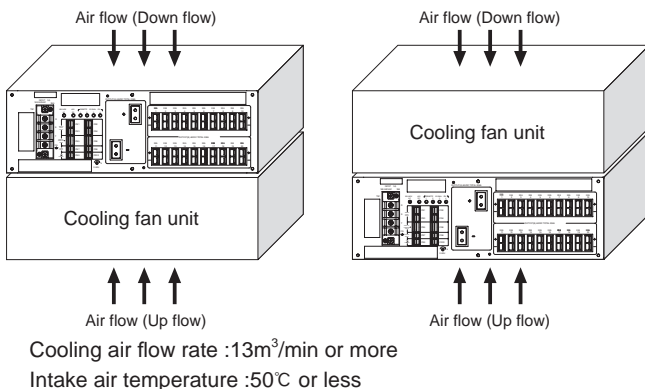
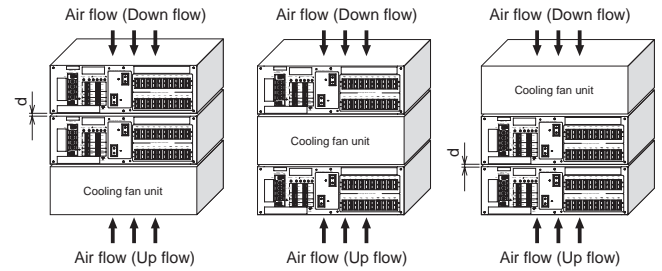

Fig.3.1 Cooling methods for use of single unit

### ② Cooling methods for use of 2 units



d :gap of power supply units. (1.5mm ≤ d ≤ 6mm)

Cooling air flow rate :13m<sup>3</sup>/min or more

Intake air temperature :35°C or less

Fig.3.2 Cooling methods for use of 2 units

### ③ Cooling methods for use of 3 units

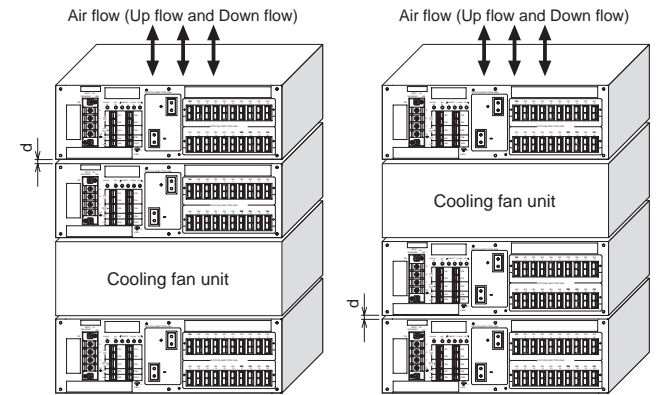

d :gap of power supply units. (1.5mm ≤ d ≤ 6mm)

Cooling air flow rate :13m<sup>3</sup>/min or more

Intake air temperature :35°C or less

Fig.3.3 Cooling methods for use of 3 units

- Stacking 4 or more units is not allowed.

## 3.3 Expected Life

- Expected Life is 10 years based on the cooling condition 3.2.

## 3.4 Warranty

- Warranty is 3 years.

# 4 Others

## 4.1 Output Voltage Monitor

- Output voltage monitor (+M, -M) is available for use (SCHA10000T : CN9,10, SCDA10000T : CN7,8) . Connector locations and pin assignment are shown on the external view.
- Fig.4.1 shows the internal circuit of monitor (+M, -M) terminal.
- Not allow to draw output current from +M, -M.

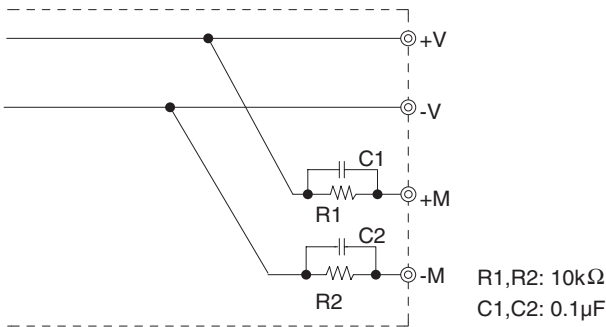

Fig.4.1 Internal circuit of output voltage monitor

## 4.2 Output Current Monitor

- You can monitor an output current by measuring a voltage between the terminal CTB (SCHA10000T : CN5,6, SCDA10000T : CN3,4) and -V (COM). Connector locations and pin assignment are shown on the external view.
- Fig.4.2 shows the relationship between the voltage of the terminal CTB and the load factor. The output current shown in Fig.4.2 should be used only as a guide.

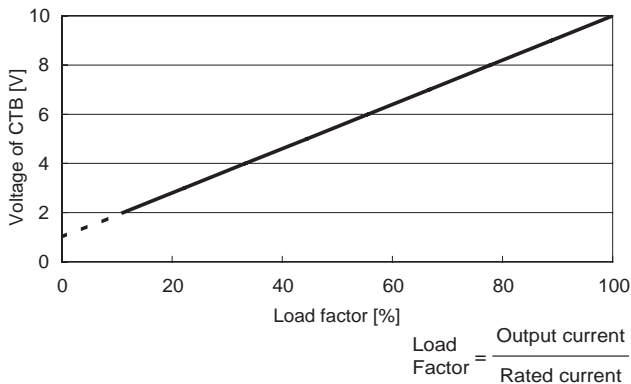

Fig.4.2 Load factor conversion graph

**Note :**

- Careful wire connection is needed to avoid a malfunction caused by noise.
- Use a measuring instrument which has 500kΩ input impedance or more.
- Do not short between CTB and -V (COM) because of possibility of failure.

## 4.3 External output voltage control function/ Constant current regulation

- The power supplies have an external output voltage control function. The output voltage can be adjusted by applying external voltage between the terminal SLV and COM. The calculation formula is ① as following.

$$\text{Output Voltage} = (\text{The voltage between SLV and COM}) \times 10 \text{ [V]} \dots\dots\dots \text{①}$$

Table 4.1 Outout voltage adjustment range

Model	Output voltage adjustment range [V]
W/O option "-Y1"	35.0 - 52.8
W/ option "-Y1"	approximately 0 - 58.8

- Negative voltage to SLV terminal may cause failure.
- There is more than one method to adjust the output voltage, including the methods to use external resistors and external power supplies. Since each method has different characteristic, please contact us for details.
- SC series can be used as a constant current power supply by using output current monitor function and external output voltage control function. To use the SC series as a constant current power supply, the external control circuit is necessary. Please contact us for details of external circuit. To use SC series as a constant current power supply, it is necessary to order Option-Y1 units.

## 4.4 Isolation

- When you run a Hi-Pot test as receiving inspection, gradually increase the voltage to start. When you shut down, decrease the voltage gradually by using a dial. Please avoid a Hi-Pot tester with a timer because, when the timer is turned ON or OFF, it may generate a voltage a few times higher than the applied voltage.
- When you test a unit for isolation between the input and output or between the output and the terminal FG, short-circuit between the output, System ON/OFF, Remote signal ON/OFF and Alarm.
- When you test a unit for isolation between the output and System ON/OFF or between the output and Remote signal ON/OFF or between the output and Alarm, short-circuit between the System ON/OFF, Remote signal ON/OFF and Alarm.

## 4.5 External Component (Noise Filter)

- You can have the power supplies comply with EN55011 Group1-B, EN55022-B, CISPR22-B, and FCC-B by connecting an external noise filter.

Recommended noise filter : TAC-50-223 (COSEL)

# 5 Options

## 5.1 Outline of Options

\*Please inquire us for details of specifications and delivery timing.  
 \*You can combine multiple options. Some options, however, cannot be combined with other options. Please contact us for details.

**-R**

■Specification with reversed logic for System ON/OFF operation.  
 System ON/OFF specification of Option-R is on Table5.1.  
 The internal circuit is on Fig.1.4.

Table 5.1 System ON/OFF specification of Option-R

Output	System ON/OFF	Remote signal ON/OFF
ON	Open (High) (Open voltage 2.5V - 5.0V) (Absolute maximum rating 30V)	Low (0 - 0.5V, less than 1000mA)
OFF	Short (Low) (Less than 1V, less than 5mA)	High or Open (Absolute maximum rating 30V)

**-Y1**

■The output voltage can be adjusted up to 58.8V from approximately 0V by applying external voltage between the terminal SLV and COM.  
 ■Output voltage is accordance with Fig.5.1 against the external voltage.  
 The calculation formula is ① as following.

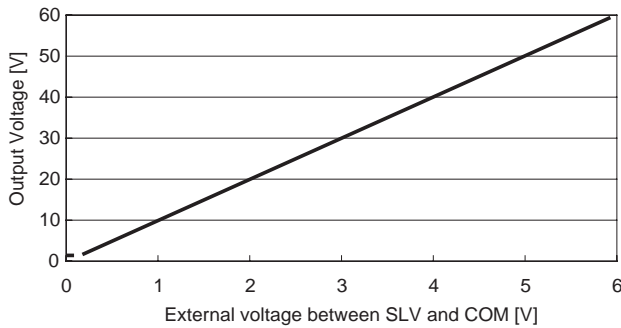

Fig.5.1 Relationship between the voltage of the terminal SLV and the output

Output Voltage = (The voltage between SLV and COM) × 10 [V]  
 ..... ①

■In case of using external resistor, the upper output voltage adjustment range is limited up to the voltage adjusted by output voltage adjustable potentiometer.  
 In advance, Maximum output voltage should be adjusted by output voltage adjustable potentiometer.

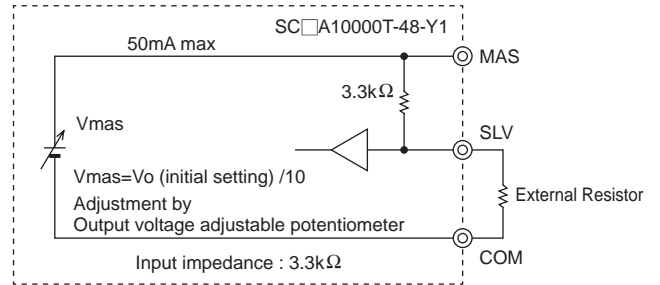

Fig.5.2 The internal circuit of SLV

■Output voltage factory setting is 47.0 - 49.0V.  
 ■Normal output voltage adjustment range is with in 45.0 - 58.8V by output voltage adjustable potentiometer.  
 ■Low-voltage protection function is disabled.  
 ■Negative voltage to SLV terminal may cause failure.  
 ■If you need any further detail, please contact us for the assistance.