

Basic Characteristics Data

Model	Circuit method	Switching frequency [kHz]	Input current [A]	Rated input fuse	Inrush current protection	PCB/Pattern			Series/Parallel operation availability	
						Material	Single sided	Double sided	Series operation	Parallel operation
CDS4004802	Forward converter	360	6 *1	-	-	Aluminum	Yes		Yes	Yes
CDS4004803	Forward converter	360	9 *1	-	-	Aluminum	Yes		Yes	Yes
CDS4004805	Forward converter	360	10 *1	-	-	Aluminum	Yes		Yes	Yes
CDS4004807	Forward converter	360	10 *1	-	-	Aluminum	Yes		Yes	Yes
CDS4004812	Forward converter	360	12 *1	-	-	Aluminum	Yes		Yes	Yes
CDS4004815	Forward converter	360	12 *1	-	-	Aluminum	Yes		Yes	Yes
CDS4004824	Forward converter	360	12 *1	-	-	Aluminum	Yes		Yes	Yes
CDS4004828	Forward converter	360	12 *1	-	-	Aluminum	Yes		Yes	Yes
CDS5002428H	Forward converter	360	24 *2	-	-	Aluminum	Yes		Yes	Yes
CDS6002412	Forward converter	360	30 *2	-	-	Aluminum	Yes		Yes	Yes
CDS6002412H	Forward converter	360	29 *2	-	-	Aluminum	Yes		Yes	Yes
CDS6002428	Forward converter	360	30 *2	-	-	Aluminum	Yes		Yes	Yes
CDS6002428H	Forward converter	360	29 *2	-	-	Aluminum	Yes		Yes	Yes
CDS6004812	Forward converter	360	17 *1	-	-	Aluminum	Yes		Yes	Yes
CDS6004828	Forward converter	360	17 *1	-	-	Aluminum	Yes		Yes	Yes

*1 The value of input current is at DCIN48V and rated load.

*2 The value of input current is at DCIN24V and rated load.

1	Pin Connection	H-48
2	Connection for Standard Use	H-48
3	Wiring Input/Output Pin	H-49
3.1	Wiring input pin	H-49
3.2	Wiring output pin	H-50
4	Function	H-50
4.1	Overcurrent protection	H-50
4.2	Overvoltage protection	H-50
4.3	Thermal detection/Thermal protection	H-50
4.4	Inverter operation monitor	H-50
4.5	Remote ON/OFF	H-51
4.6	Remote sensing	H-51
4.7	Adjustable voltage range	H-52
4.8	Isolation	H-52
5	Series and Parallel Operation	H-52
5.1	Series operation	H-52
5.2	Parallel operation/Master-slave operation	H-52
5.3	N+1 redundant operation	H-53
6	Implementation · Mounting Method	H-53
6.1	Mounting method	H-53
6.2	Stress onto the pins	H-54
6.3	Cleaning	H-54
6.4	Soldering	H-54
6.5	Derating	H-54
7	Safety Considerations	H-54

1 Pin Connection

●CDS400

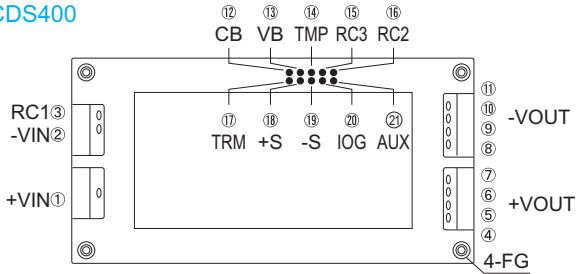

●CDS500/600

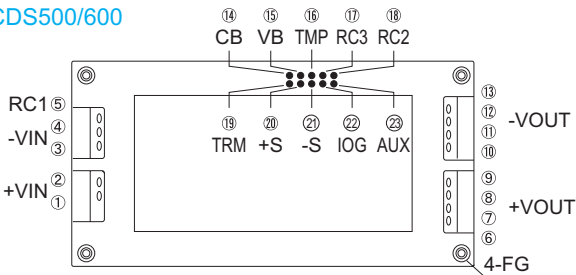

Fig.1.1 Pin Connection(bottom view)

●CDS400 Table 1.1 Pin Connection and function

No.	Pin Connection	Function
①	+VIN	+DC input
②	-VIN	-DC input
③	RC1	Remote ON/OFF(Input side)
④ ⑤ ⑥ ⑦	+VOUT	+DC output
⑧ ⑨ ⑩ ⑪	-VOUT	-DC output
⑫	CB	Current balance
⑬	VB	Voltage balance
⑭	TMP	Thermal detection signal
⑮	RC3	Remote ON/OFF(output side)
⑯	RC2	
⑰	TRM	Adjustment of output voltage
⑱	+S	+Remote sensing
⑲	-S	-Remote sensing
⑳	IOG	Inverter operation monitor
㉑	AUX	Auxiliary power supply
—	FG	Mounting hole(FG)

No.	Pin Connection	Reference
①	+VIN	3.1 "Wiring input pin"
②	-VIN	
③	RC1	4.5 "Remote ON/OFF"
④ ⑤ ⑥ ⑦	+VOUT	3.2 "Wiring output pin"
⑧ ⑨ ⑩ ⑪	-VOUT	
⑫	CB	5.2 "Parallel operation/Master-slave operation"
⑬	VB	
⑭	TMP	4.3 "Thermal detection/Thermal protection"
⑮	RC3	4.5 "Remote ON/OFF"
⑯	RC2	
⑰	TRM	4.7 "Adjustable voltage range"
⑱	+S	4.6 "Remote sensing"
⑲	-S	
⑳	IOG	4.4 "Inverter operation monitor"
㉑	AUX	4.5 "Remote ON/OFF"
—	FG	3.1 "Wiring input pin"

●CDS500/600 Table 1.2 Pin Connection and function

No.	Pin Connection	Function
① ②	+VIN	+DC input
③ ④	-VIN	-DC input
⑤	RC1	Remote ON/OFF(Input side)
⑥ ⑦ ⑧ ⑨	+VOUT	+DC output
⑩ ⑪ ⑫ ⑬	-VOUT	-DC output
⑭	CB	Current balance
⑮	VB	Voltage balance
⑯	TMP	Thermal detection signal
⑰	RC3	Remote ON/OFF(output side)
⑱	RC2	
⑲	TRM	Adjustment of output voltage
⑳	+S	+Remote sensing
㉑	-S	-Remote sensing
㉒	IOG	Inverter operation monitor
㉓	AUX	Auxiliary power supply
—	FG	Mounting hole(FG)

No.	Pin Connection	Reference
① ②	+VIN	3.1 "Wiring input pin"
③ ④	-VIN	
⑤	RC1	4.5 "Remote ON/OFF"
⑥ ⑦ ⑧ ⑨	+VOUT	3.2 "Wiring output pin"
⑩ ⑪ ⑫ ⑬	-VOUT	
⑭	CB	5.2 "Parallel operation/Master-slave operation"
⑮	VB	
⑯	TMP	4.3 "Thermal detection/Thermal protection"
⑰	RC3	4.5 "Remote ON/OFF"
⑱	RC2	
⑲	TRM	4.7 "Adjustable voltage range"
⑳	+S	4.6 "Remote sensing"
㉑	-S	
㉒	IOG	4.4 "Inverter operation monitor"
㉓	AUX	4.5 "Remote ON/OFF"
—	FG	3.1 "Wiring input pin"

2 Connection for Standard Use

■In order to use the power supply, it is necessary to wire as shown in Fig.2.1.

{ Reference: 3 "Wiring Input/Output Pin"
6.5 "Derating" }

■Short the following pins to turn on the power supply.

-VIN↔RC1, +VOUT↔+S, -VOUT↔-S

{ Reference: 4.5 "Remote ON/OFF"
4.6 "Remote sensing" }

■The CDS Series handles only the DC input.

Avoid applying AC input directly.
It will damage the power supply.

■Operate with the conduction cooling(e.g. heat radiation from the aluminum base plate to the attached heat sink).

{ Reference: 6.5 "Derating" }

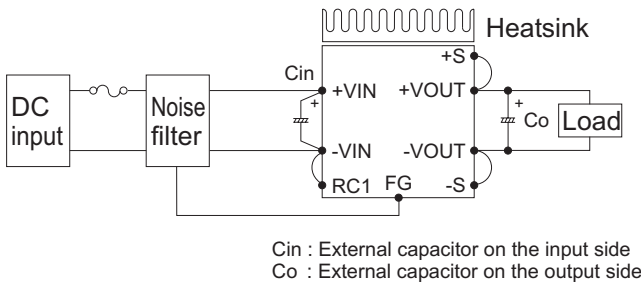

Fig.2.1 Connection for standard use

3 Wiring Input/Output Pin

3.1 Wiring input pin

(1) External fuse

- Fuse is not built-in on input side. In order to protect the unit, install the normal blow type fuse on input side.
- When the input voltage from a front end unit is supplied to multiple units, install a regular type fuse in each unit.

Table 3.1 Recommended fuse(Normal-blow type, maximum value)

Model	CDS40048	CDS50024/CDS60024	CDS60048
Rated current	30A	75A	30A

(2) Noise filter/Decoupling capacitor

- Install an external noise filter for low line-noise and for stable operation of the power supply.
- Install a correspondence filter, if a noise standard meeting is required or if the surge voltage may be applied to the unit.

(3) External capacitor on the input side

- Install an external capacitor Cin between +VIN and -VIN input pins for low line-noise and for stable operation of the power supply.

CDS40048: more than 100 μ F
CDS50024/CDS60024: more than 1000 μ F
CDS60048: more than 470 μ F

- When the line impedance is high or the input voltage rise quickly at start-up(less than 10 μ s), install a capacitor Cin between +VIN and -VIN input pins(within 50mm from pins).

(4) Input voltage range/Input current range

- Input voltage ripple should be less than 2Vp-p.
- Make sure that the voltage fluctuation, including the ripple voltage, will not exceed the input voltage range.
- Use a front end unit with enough power, considering the start-up current Ip of this unit.

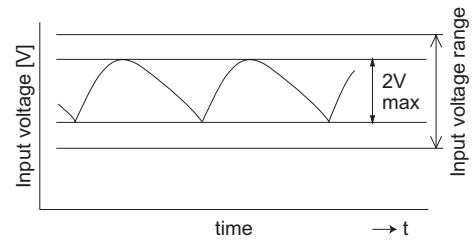

Fig.3.1 Input voltage ripple

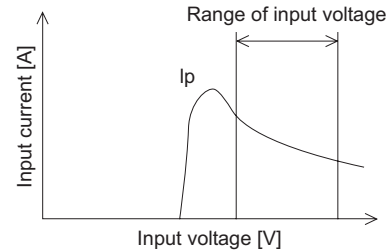

Fig.3.2 Input current characteristics

(5) Operation with AC input

- The CDS series handles only for the DC input. A front end unit(AC/DC converter) is required when the CDS series is operated with AC input.

(6) Reverse input voltage protection

- Avoid the reverse polarity input voltage. It will break the power supply. It is possible to protect the unit from the reverse input voltage by installing an external diode.

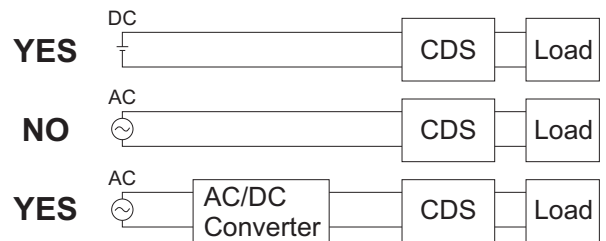

Fig.3.3 Use with AC input

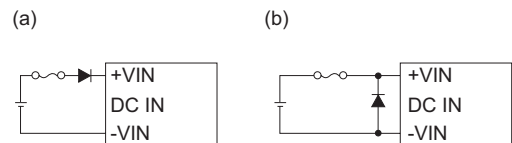

Fig.3.4 Reverse input voltage protection

3.2 Wiring output pin

- Install an external capacitor C_o between +VOUT and -VOUT pins for stable operation of the power supply.
Recommended capacitance of C_o is shown in Table 3.2.

Table 3.2 Recommended capacitance C_o [μ F]

Model	Capacitance
CDS4004802	6800
CDS4004803	6800
CDS4004805	4700
CDS4004807	4700
CDS4004812	470
CDS4004815	330
CDS4004824	220
CDS4004828	220
CDS5002428H	470
CDS6002412	1000
CDS6002412H	1000
CDS6002428	470
CDS6002428H	470
CDS6004812	1000
CDS6004828	470

- Select the high frequency type capacitor. Output ripple and start-up waveform may be influenced by ESR · ESL of the capacitor and the wiring impedance.
- Install a capacitor C_o near the output pins(within 100mm from the pins).

4 Function

4.1 Overcurrent protection

- Overcurrent protection is built-in and comes into effect at over 105% of the rated current.
Overcurrent protection prevents the unit from short circuit and overcurrent condition. The unit automatically recovers when the fault condition is cleared.
- When the output voltage drops at overcurrent, the average output current is reduced by intermittent operation of power supply.

4.2 Overvoltage protection

- The overvoltage protection circuit is built-in. The DC input should be shut down if overvoltage protection is in operation. The minimum interval of DC recycling for recovery is for 2 to 3 minutes (*) or input terminal voltage is decreased less than 1V.
* The recovery time varies depending on input voltage and input capacity.

Remarks:

Please note that devices inside the power supply might fail when voltage more than rated output voltage is applied to output terminal of the power supply. This could happen when the customer tests the overvoltage performance of the unit.

4.3 Thermal detection/Thermal protection

- Thermal detection(TMP) and protection circuit are built-in.
- When overheat is detected, thermal detection signal(TMP) turns "L" from "H".
TMP circuit is designed as shown in Fig.4.1, and specification is shown as in Table 4.1.
- When overheating continues after detecting the TMP signal, the output will be shut down by the thermal protection circuit.
When this function comes into effect, input voltage should be shut off, and eliminate all possible causes of overheat condition and lower the temperature of the unit to the normal level.

4.4 Inverter operation monitor

- By using the inverter operation monitor(IOG), malfunction of the inverter can be monitored.
When inverter operation is in following mode ①, ② or ③, IOG signal turns "H" from "L" within 1 second.
- IOG circuit is designed as shown in Fig.4.1 and specification is shown in Table 4.1.
- ① Malfunction of inverter.
- ② The output voltage drops by 60% or less of the rated voltage.
- ③ When output wattage is decreased radically to less than 10% of rated wattage.

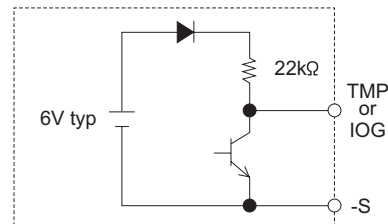

Fig.4.1 TMP, IOG circuit

Table 4.1 Specification of TMP, IOG

No.	Item	TMP	IOG
1	Function	Normal operation "H"	Normal operation "L"
		Overheat detection "L"	Malfunction of inverter "H"
2	Base pin	-S	
3	Level voltage "L"	0.5Vmax at 5mA	
4	Level voltage "H"	5V typ	
5	Maximum sink current	10mA max	
6	Maximum applicable voltage	35V max	

4.5 Remote ON/OFF

Remote ON/OFF circuit is built-in on both side of input(RC1) and output(RC2 · RC3).
Output can be controlled by either circuit.

(1) Input side remote ON/OFF(RC1)

The ground pin of input side remote ON/OFF circuit is "-VIN" pin.
Between RC1 and -VIN: Output voltage is ON at "Low" level or short circuit(0 - 1.0V).
Between RC1 and -VIN: Output voltage is OFF at "High" level or short circuit(3.5 - 7.0V).

When RC1 is "Low" level, fan out current is 0.3mA typ. When Vcc is applied, use $3.5 \leq V_{cc} \leq 7V$.

When remote ON/OFF function is not used, please short between RC1 and -VIN.

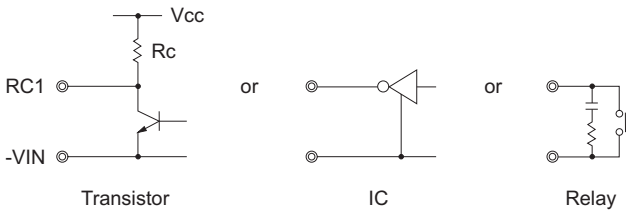

Fig.4.2 RC1 connection example

(2)Output side remote ON/OFF(RC2 · RC3)

Table 4.2 Specification of output side remote ON/OFF(RC2 · RC3)

No.	Item	RC2 · RC3		
		Fig.4.3 (a)	Fig.4.3 (b)	Fig.4.3 (c)
1	Wiring method	Power ON "H"	Power ON "H"	Power ON "L"
2	Function	Power ON "H"	Power ON "H"	Power ON "L"
3	Base pin	RC2	-S	-S and RC2
4	Power ON	Open (0.1mA max)	Short (0.5V max)	Short (0.5V max)
5	Power OFF	Short (3mA min)	Short (0.1mA max)	Open (0.1mA max)

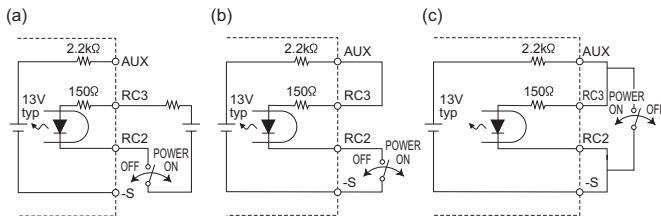

Fig.4.3 RC2 · RC3 connection example

- When output side remote ON/OFF function is used, please short between RC1 and -VIN.
- Do not connect RC2 and RC3 with anywhere if remote ON/OFF is not used.

- Make sure that sink current of output side remote ON/OFF circuit should be less than 12mA.

(3) Auxiliary power supply for remote ON/OFF(AUX)

- AUX is built in for operating the output side remote ON/OFF(RC2 · RC3).
If AUX is not used for RC2 · RC3, AUX can be used for IOG or TMP signal output by opto coupler.
- Short protection resistance(2.2kΩ) is built in.
Output voltage decreases as the output current increases.
(AUX voltage at open circuit: 16V max)

4.6 Remote sensing

(1) When the remote sensing function is not in use

- When the remote sensing function is not in use, it is necessary to confirm that pins are shorted between +S & +VOUT and between -S & -VOUT.
Wire between +S & +VOUT and between -S & -VOUT as short as possible.
Loop wiring should be avoided.
This power supply might become unstable by the noise coming from poor wiring.

(2) When the remote sensing function is in use

- Twisted-pair wire or shield wire should be used for sensing wire.
- Thick wire should be used for wiring between the power supply and a load.
Line drop should be less than 0.5V.
Voltage between +VOUT and -VOUT should remain within the output voltage adjustment range.
- If the sensing patterns are short, heavy-current is drawn and the pattern may be damaged.
The pattern disconnection can be prevented by installing the protection parts as close as a load.

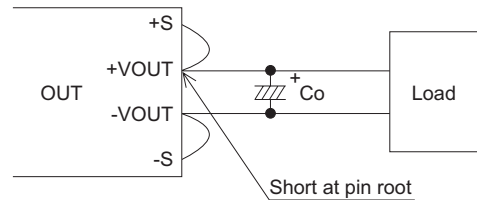

Fig.4.4 Connection when the remote sensing is not in use

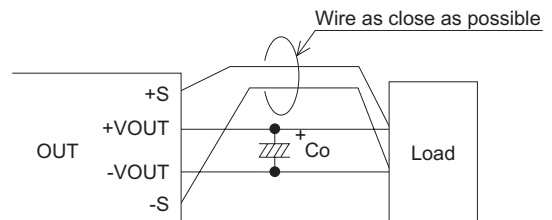

Fig.4.5 Connection when the remote sensing is in use

4.7 Adjustable voltage range

- Output voltage is adjustable by the external potentiometer or by applied voltage externally.
CDS5002428H, CDS6002412H, CDS6002428H : When the output voltage adjustment range is 101% or more, the input voltage range is limited (Fig.4.6).
- When the output voltage is raised, decrease the output current so as not to exceed the maximum output wattage.
- When the output voltage adjustment is used, note that the overvoltage protection circuit operates when the output voltage sets too high.

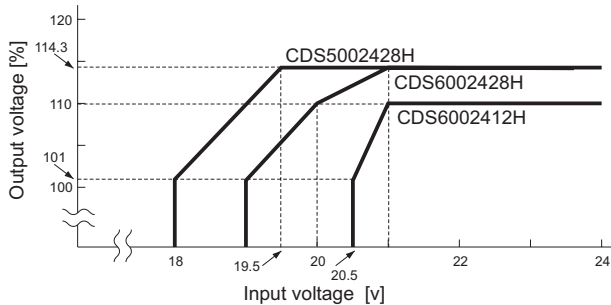

Fig.4.6 Input voltage derating curve

(1) Adjusting method by external resistor

- By connecting the external potentiometer (VR1) and resistors (R1, R2), output voltage becomes adjustable, as shown in Fig.4.6, recommended external parts are shown in Table 4.3.
- The wiring to the potentiometer should be as short as possible. The temperature coefficient becomes worse, depending on the type of a resistor and potentiometer. Following parts are recommended for the power supply.
Resistor-----Metal film type, coefficient of less than ±100ppm/°C
Potentiometer-- Cermet type, coefficient of less than ±300ppm/°C
- When the output voltage adjustment is not used, open the TRM pin and VB pin respectively.

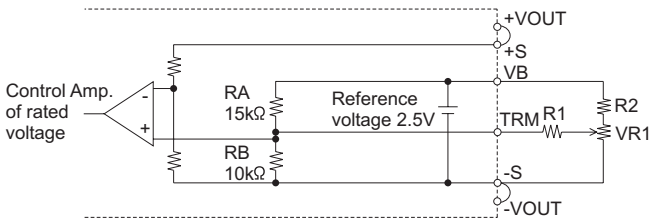

Fig.4.7 Output voltage control circuit

Table 4.3 Recommended value of external potentiometer & resistor

No.	Adjustable range [%]	Number of unit	External parts value [Ω]		
			VR1	R1	R2
1	±5	Single	5k	75k	1k
2		2sets		36k	
3		3sets		24k	
4	±10	Single	5k	36k	910
5		2sets		18k	
6		3sets		12k	

(2) Adjusting method by applying external voltage

- By applying the voltage externally at TRM, output voltage become adjustable.
- Output voltage is calculated by the following equation.
(Output voltage)
= (Applied voltage externally) × (Rated output voltage)

4.8 Isolation

- For a receiving inspection, such as Hi-Pot test, gradually increase (decrease) the voltage for a start(shut down). Avoid using Hi-Pot tester with the timer because it may generate voltage a few times higher than the applied voltage, at ON/OFF of a timer.
- Be sure to apply DC voltage when Hi-pot test is performed to the part which is specified as DC voltage. And also set the current limit of Hi-pot tester at 10mA. Don't apply AC voltage, otherwise this may damage the power supply.
(CDS40048 series : INPUT-OUTPUT, INPUT-FG)

5 Series and Parallel Operation

5.1 Series operation

- Series operation is available by connecting the outputs of two or more power supplies, as shown below. Output current in series connection should be lower than the lowest rated current in each unit.

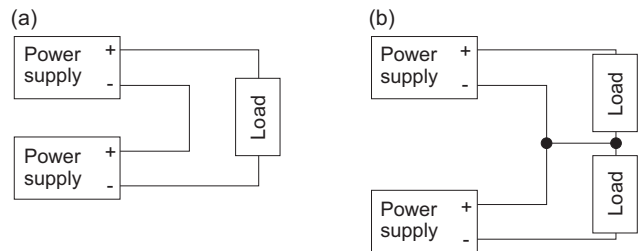

Fig.5.1 Examples of series operation

5.2 Parallel operation/Master-slave operation

- Parallel operation is available by connecting the units as shown in Fig.5.2.
- As variance of output current drew from each power supply is maximum 10%, the total output current must not exceed the value determined by the following equation.

(Output current in parallel operation)
= (the rated current per unit) × (number of unit) × 0.9

When the number of units in parallel operation increases, input current increase at the same time. Adequate wiring design for input circuitry is required, such as circuit pattern, wiring and current capacity for equipment.

In parallel operation, the maximum operative number of units is 11.

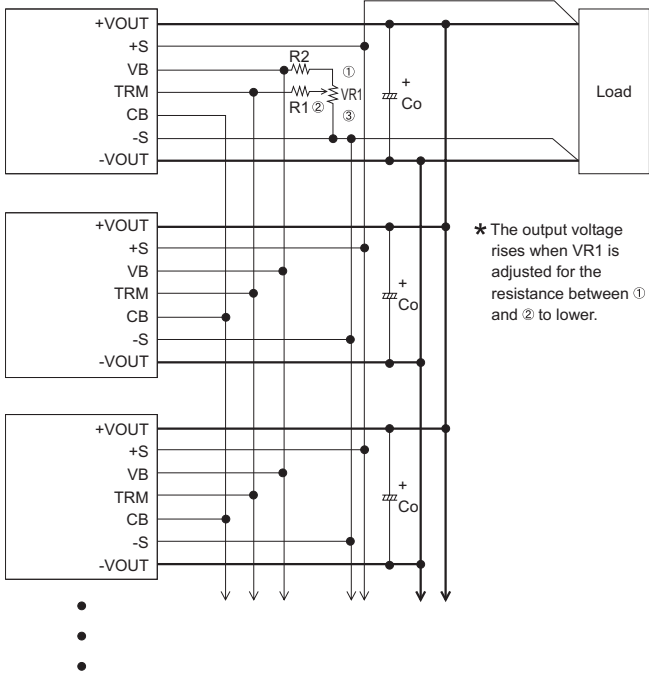

Fig.5.2 Examples of parallel operation

- When output voltage adjustment is not in use. TRM wiring, R1, R2 and VR are not necessary.
- Thick wire should be used for wiring between the power supply and load, and line drop should be less than 0.3V.
- When the output-line impedance is high, the power supply is become unstable.
Use same length and thickness(width) wire(pattern) for the current balance improvement.
- Connect each input pin for the lowest possible impedance.
- When the number of the units in parallel operation increases, input current increases. Adequate wiring design for input circuitry such as circuit pattern, wiring and current for equipment is required.
- Connect the sensing line and the power line by one point after connecting each power supply's sensing pins(+S, -S). In multiple operation, sensing wires should be connected between each units for the muster connection to a load.
- Output current should be 10% or more of the total of the rated output current in parallel operation.
If less than 10%, the IOG signal might become unstable, and output voltage slightly increasing(max5%).

- IOG signal might be unstable for one second when the units are turned on in parallel operation.
- A sound may occur from power supply at parallel operating.

5.3 N+1 redundant operation

- It is possible to set N+1 redundant operation for improving reliability of power supply system.
- Purpose of redundant operation is to ensure stable operation in the event of single power supply failure.
Since extra power supply is reserved for the failure condition, so total power of redundant operation is equal to N-1.

6 Implementation - Mounting Method

6.1 Mounting method

- The unit can be mounted in any direction. When two or more power supplies are used side by side, position them with proper intervals to allow enough air ventilation. Aluminum base plate temperature around each power supply should not exceed the temperature range shown in derating curve.
- Avoid placing the DC input line pattern lay out underneath the unit, it will increase the line conducted noise. Make sure to leave an ample distance between the line pattern lay out and the unit. Also avoid placing the DC output line pattern underneath the unit because it may increase the output noise. Lay out the pattern away from the unit.
- High-frequency noise radiates directly from the unit to the atmosphere. Therefore, design the shield pattern on the printed circuit board and connect its one to FG.
The shield pattern prevents noise radiation.
- The maximum current is 25A per input pin and output pin.

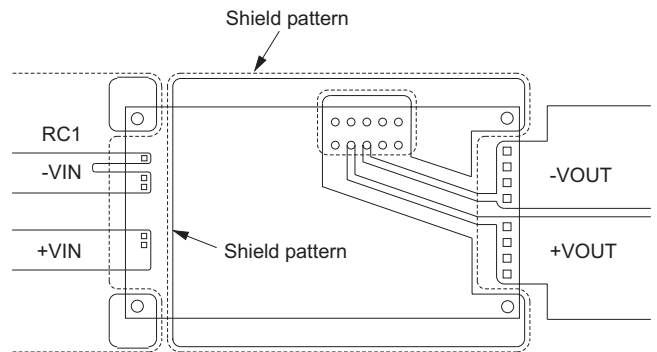

Fig.6.1 Shield pattern lay out(bottom view)

■Option“-M” is available, as shown in Table 6.1.

Table 6.1 Mounting hole

	Mounting hole
Standard	φ3.4 thru
Optional : -M	M3 tapped

6.2 Stress onto the pins

- When too much stress is applied to the pins of the power supply, the internal connection may be weakened.
As shown in Fig.6.2 avoid applying stress of more than 29.4N(3kgf) on the input pins/output pins(A part) and more than 9.8N(1kgf) to the signal pins(B part).
- The pins are soldered on PCB internally, therefore, do not pull or bend them with abnormal forces.
- Mounting hole diameter of PCB should be 3.5mm to reduce the stress onto the pins.
- Fix the unit on PCB(fixing fittings) by screws to reduce the stress onto the pins. Be sure to mount the unit first, then solder the unit.

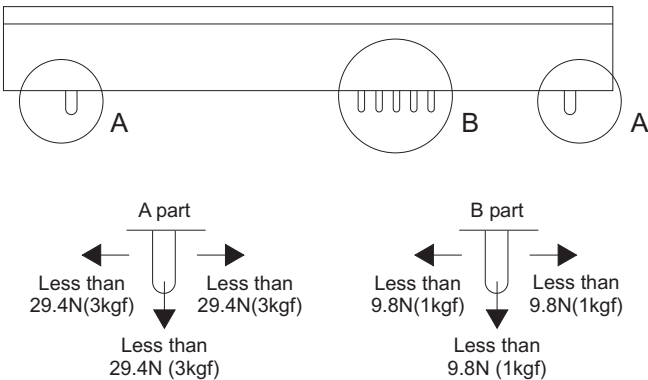

Fig.6.2 Stress onto the pins

6.3 Cleaning

- Clean the product with a brush. Prevent liquid from getting into the product.
Do not soak the product into liquid.
- Do not stick solvent to a name plate or a resin case.
(If solvent sticks to a name plate or a resin case, it will cause to change the color of the case or to fade letters on name plate away.)
- After cleaning, dry them enough.

6.4 Soldering

- Flow soldering :260°C less than 15 seconds.
- Soldering iron
DC IN/DC OUT/RC1 :450°C less than 5 seconds.
Signal pins :350°C less than 3 seconds(less than 20w).

6.5 Derating

■Use with the conduction cooling(e.g. heat radiation by conduction from the aluminum base plate to the attached heat sink).

Fig.6.3 shows the derating curve based on the aluminum base plate temperature. In the hatched area, the specification of Ripple and Ripple Noise is different from other areas.

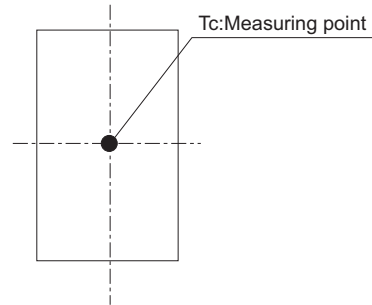
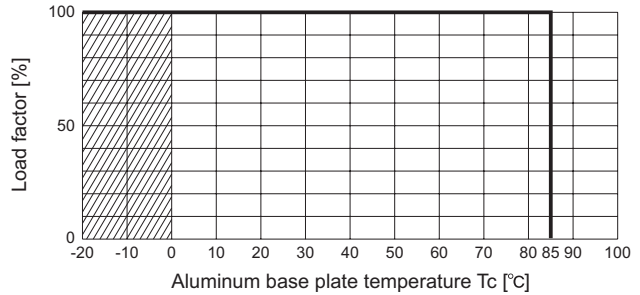

Fig.6.3 Derating curve

7 Safety Considerations

- To apply for safety standard approval using this power supply, the following conditions must be met.
 - This unit must be used as a component of the end-use equipment.
 - The equipment does neither contain any basic nor double/reinforced insulation between input and output, and base plate.
If the input voltage is greater than 60VDC, this has to be provided by the end-use equipment according to the final build in condition.
 - Safety approved fuse must be externally installed on input side.