

- Constant current circuit -

PBA and ACE series are available as a current source power supply by adding external circuit. The main feature of each series is shown below.

PBA series [PBA300F ~ 1500F and 1500T]

*PBA series is suitable for general application which requires a current source power supply.

- 1.Constant current circuit by using a shunt resistor
- 2.Constant current circuit by using a current sensor
- 3.Constant current circuit by using a shunt resistor in parallel operation

ACE series [module code:A-K,2A-2K]

*ACE series is suitable for the application which requires a current source power supply and multi output.

*ACE series -H option is for medical application.

- 4.Constant current circuit by using a shunt resistor

1. Constant current circuit by using a shunt resistor

■ Circuit

In PBA300F ~ 1500F and 1500T, example circuit for constant current by signal voltage is shown below.

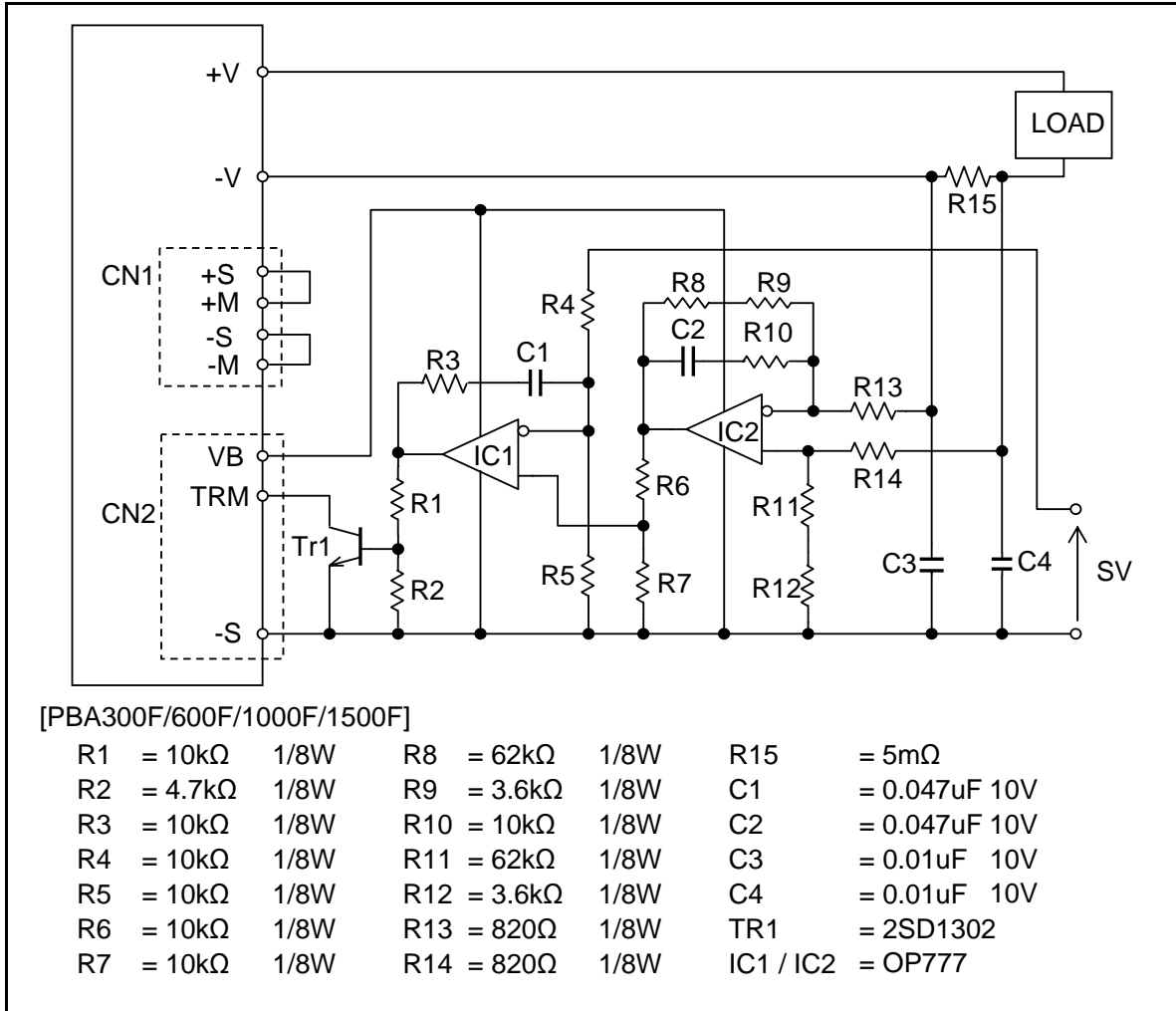

Fig.1-1 constant current circuit by using a shunt resistor

■ Explanation of Operation

In the circuit shown in Fig.1-1, the output current can be adjusted by the signal voltage (SV). For example, in case signal voltage is 4V, the output current should be 10A. And if the voltage (SV) doesn't change, the output current could be kept constantly.

Next, the operation of constant current control is shown as follows.

In this power supply, the output voltage can be adjusted by the voltage of TRM terminal. For example, in case the output current increases,

the voltage generated in R15 gets high. At this time, the noise on this voltage would reduce by IC2 (differential amplifier) and also this voltage could be amplified. Next, the output voltage of IC1 gets high by rising of the input voltage (the output voltage of IC2) and Tr1 turns ON. Because the voltage of TRM terminal gets low, the output voltage also gets low and the output current decreases.

In this way the output current could be kept constantly even if impedance in the load is changed.

■ **Note**

Please note the rating wattage of shunt resistor (R15).

Please confirm CN1 and CN2 are connected correctly. And if CN2 is unconnected, the output voltage gets the rated voltage and the power supply can not work as current source.

CN1 and CN2 are connected each other internally. Therefore, it is also possible to connect external circuit on CN1.

Please note that PG alarm will output, if the output voltage reaches less than 10% of rated voltage.

■ **Characteristic**

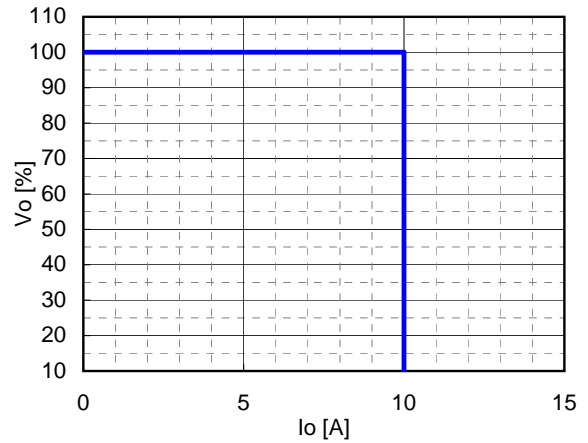

Fig.1-2 Vo - Io

*Vo : Rated output voltage

*Io : output current

2.Constant current circuit by using a current sensor

■ Circuit

In PBA300F ~ 1500F and 1500T, example circuit for constant current by signal voltage is shown below.

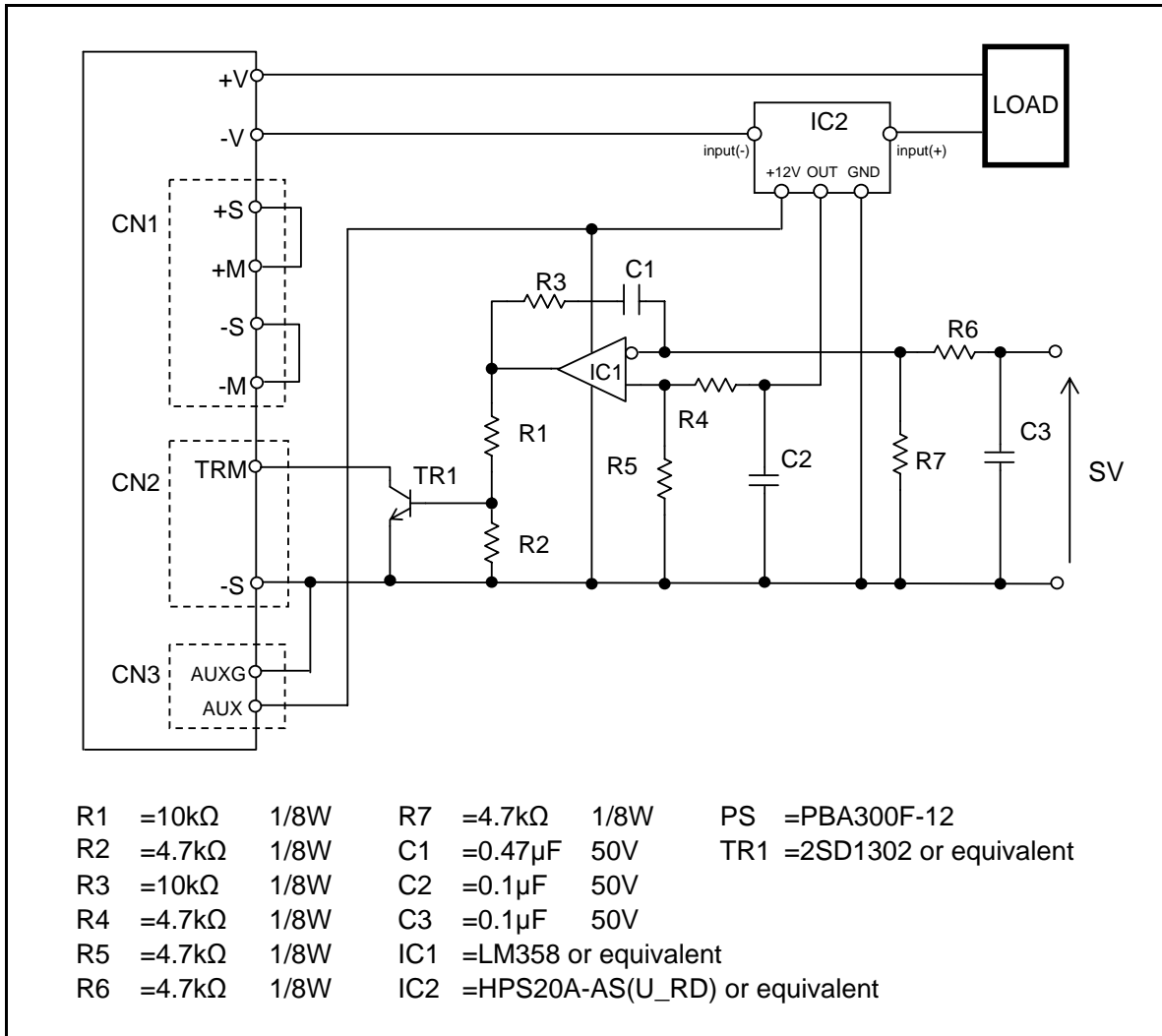

Fig.2-1 constant current circuit by using a current sensor

■ Explanation of Operation

In the circuit shown in Fig.2-1, the output current can be adjusted by the signal voltage (SV). For example, in case signal voltage is 5V, the output current should be 20A. And if the voltage (SV) doesn't change, the output current could be kept constantly.

In case that the output current is too big and the suitable shunt resistor can't be selected, the current sensor (IC2) is available to the circuit as shown in Fig.2-1.

The current sensor converts the output current to the signal of voltage like the shunt resistor.

■ Note

Please confirm CN1 and CN2,3 are connected correctly. And if CN2 or CN3 is unconnected, the output voltage gets the rated voltage and the power supply can not work as current source.

CN1 and CN2 are connected each other internally. Therefore, it is also possible to connect external circuit on CN1.

Please note that PG alarm will output, if the output voltage reaches less than 10% of rated voltage.

There is a possibility that the output voltage becomes unstable when the power supply is set in your system. If this is the case, please try to change value of R3 or C1 bigger.

■ Characteristic

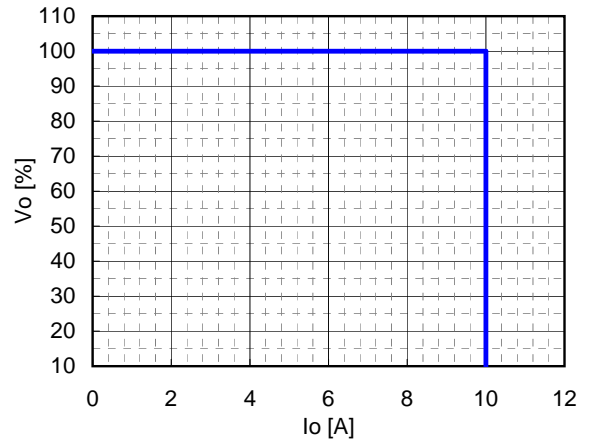

Fig.2-2 Vo - Io
 *Vo : Rated output voltage
 *Io : output current

3. Constant current circuit by using a shunt resistor

in parallel operation

■ Circuit

In PBA300F ~ 1500F and 1500T, example circuit for constant current in parallel operation is shown below.

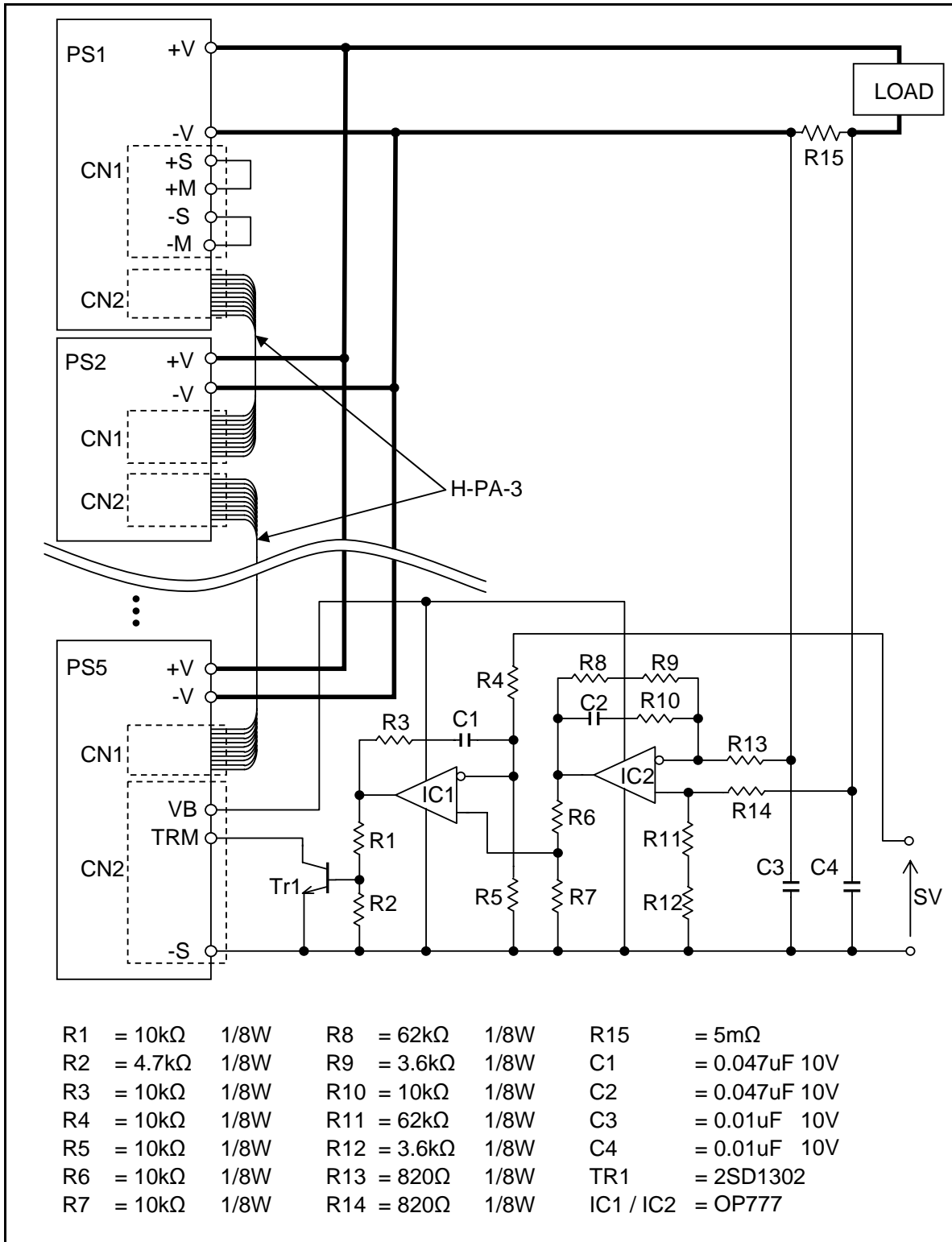

Fig.3-1 constant current circuit by using a shunt resistor in parallel operation

■ Explanation of Operation

In the circuit shown in Fig.3-1, the output current can be adjusted by the signal voltage (SV). For example, in case signal voltage is 4V, the output current should be 10A. And if the voltage (SV) doesn't change, the output current could be kept constantly.

Please connect each power supplies by harness (H-PA-3).

■ Note

Please note the rating wattage of shunt resistor (R15).

Please confirm CN1 and CN2 are connected correctly. And if CN2 is unconnected, the output voltage gets the rated voltage and the power supply can not work as current source.

Please note that PG alarm will output, if the output voltage reaches less than 10% of rated voltage.

■ Characteristic

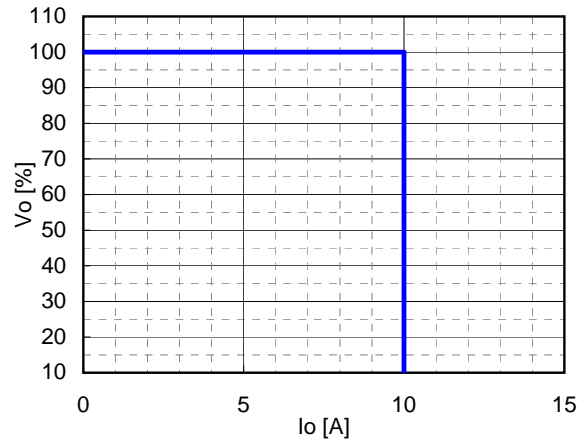

Fig.3-2 Vo - Io

*Vo : Rated output voltage

*Io : output current

4. Constant current circuit by using a shunt resistor

■ Circuit

ACE series [module code:A-K,2A-2K], example circuit for constant current is shown below.

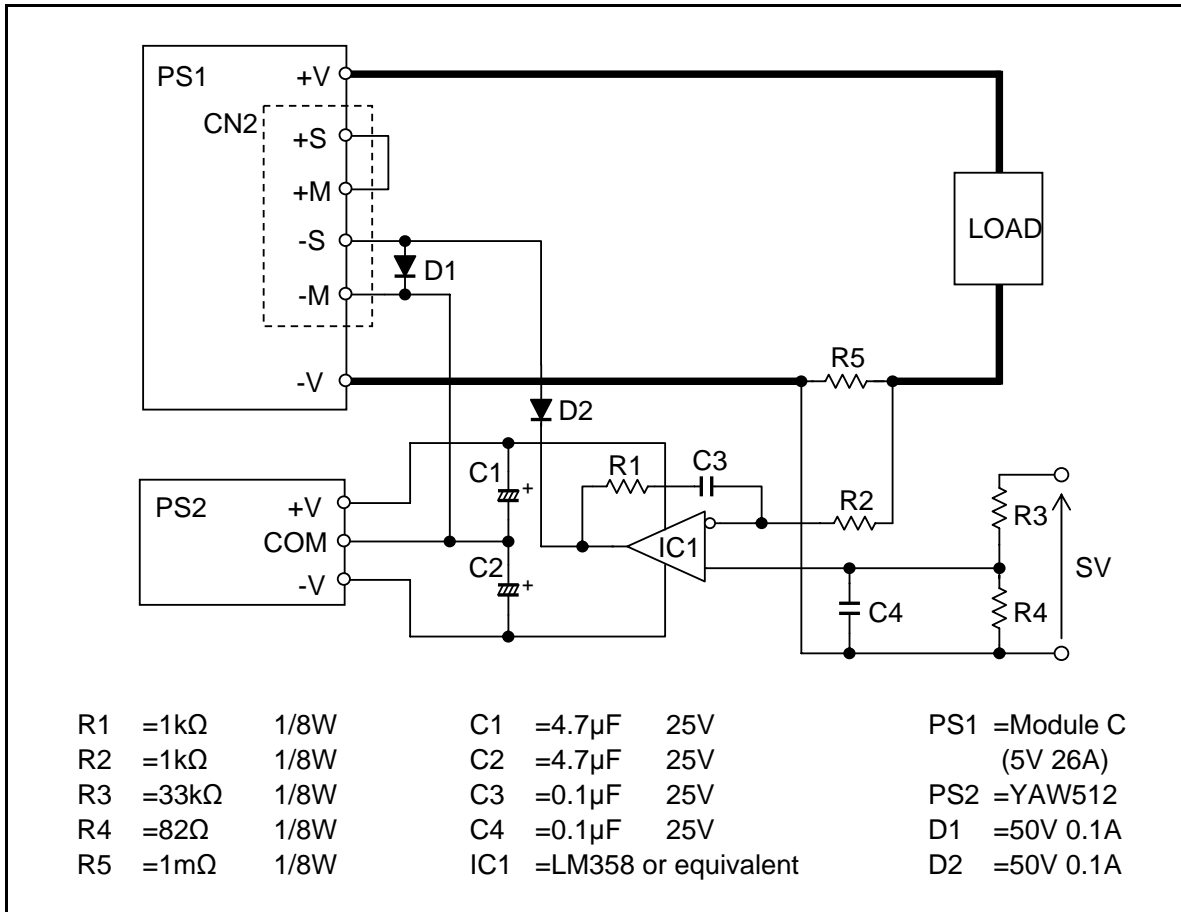

Fig.4-1 constant current circuit by using a shunt resistor

■ Explanation of Operation

In the circuit shown in Fig.4-1, the output current can be adjusted by the signal voltage (SV). For example, in case signal voltage is 10V, the output current should be 25A. And if the voltage (SV) doesn't change, the output current could be kept constantly.

Next, the operation of constant current control is shown as follows.

In this power supply, the output voltage can be adjusted by the voltage between -S and -M terminal, and if the voltage gets big, the output voltage should get small.

For example, in case the output current increases, the voltage generated in R5 gets big. Next, the output voltage of IC1 gets small by rising the input negative voltage. Therefore, because the voltage between -S and -M terminal gets big, the output voltage gets small and the output current decreases.

In this way the output current could be kept constantly even if impedance in the load is changed.

■ **Note**

In case that the output voltage is smaller than 8V approximately, AUX terminal could substitute for the external power supply.

The setting value of constant current must be the rated current or less.

■ **Characteristic**

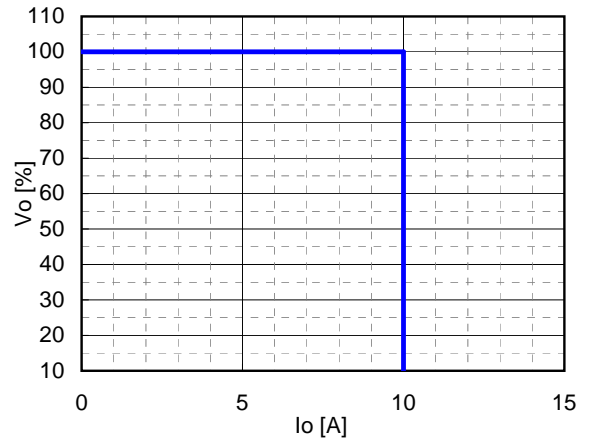

Fig.4-2 Vo - Io

*Vo : Rated output voltage

*Io : output current