



Applications Manual of DPG series



Contents

	Page
1 Overview	A-1
2 Connection for standard use	A-4
3 Wiring input / output pin	A-4
3.1 Wiring input pin	A-4
3.2 Wiring output pin	A-5
4 Function	A-7
4.1 Protection circuit	A-7
4.2 Control signals	A-8
4.3 Others	A-8
5 Series and parallel operation	A-9
5.1 Series operation	A-9
5.2 Parallel operation	A-9
6 EMI	A-9

1 Overview

- DPG series is AC-DC front-end modules for DHS or DBS series. These modules have the power factor correction and the harmonic current reduction function.
- DPG500 is able to output 300W (AC100V) /750W (AC200V), and DPG750 is able to output 500W (AC100V) /750W (AC200V). When DBS module's efficiency is 80%, 400W (AC100V) /600W (AC200V) power supply system can be configured by using DPG750.
- The power factor correction circuit of DPG consist of boost converter.
The output voltage is higher than the input voltage. When power factor correction function is disabled, rectified input voltage can still be present at the module output.
- DPF series provides control signals for system design, these signals control the DHS or DBS operation as shown in Fig.2.1

Fig. 1.1
Input current waveform
(DPG750 AC100V)

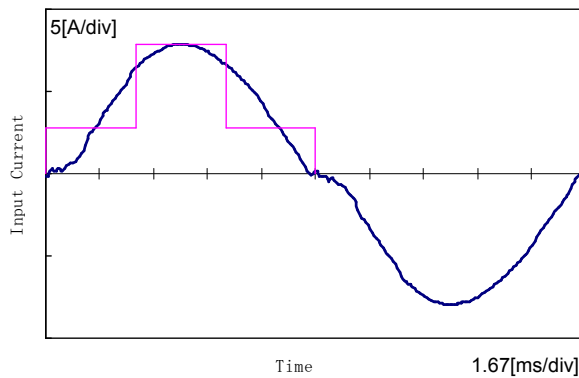

Fig. 1.2
Harmonic current
(DP750 AC100V)

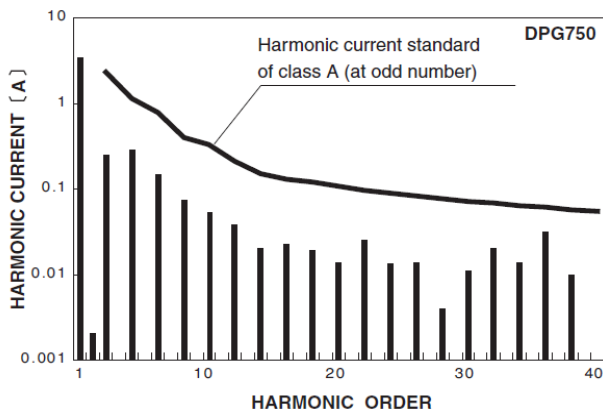

Fig. 1.3
Maximum output power
by input voltage

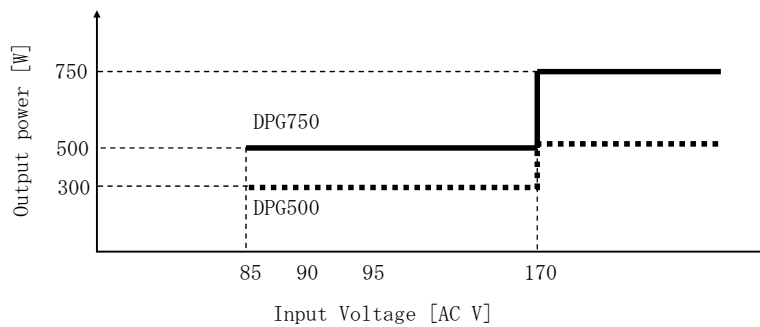

Fig. 1.4
Output voltage

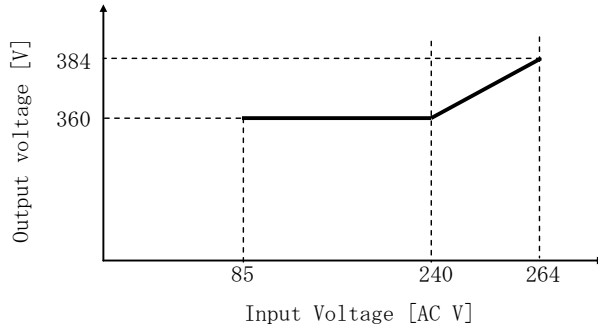

Fig. 1.5
Sequence chart

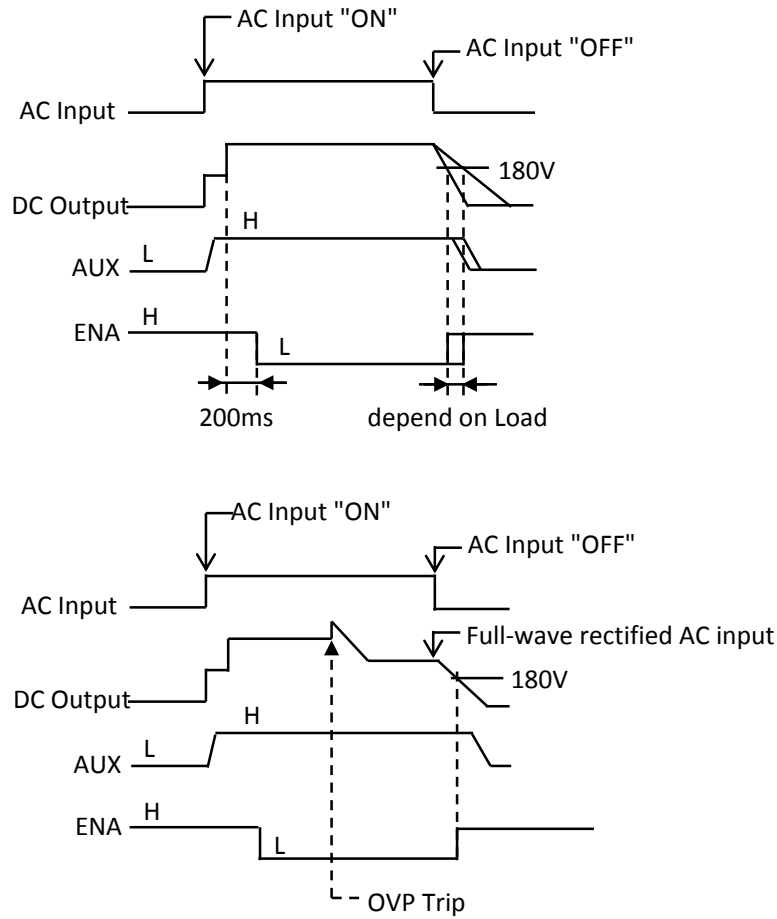
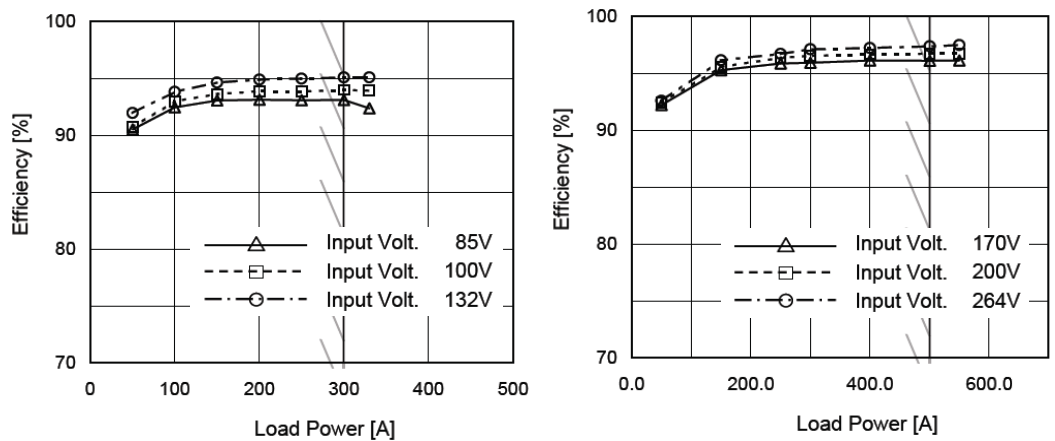

Fig. 1.6
Efficiency
(DPG500 AC85-264V)



DPG series

Fig. 1.7
Efficiency
(DPG750 AC85-264V)

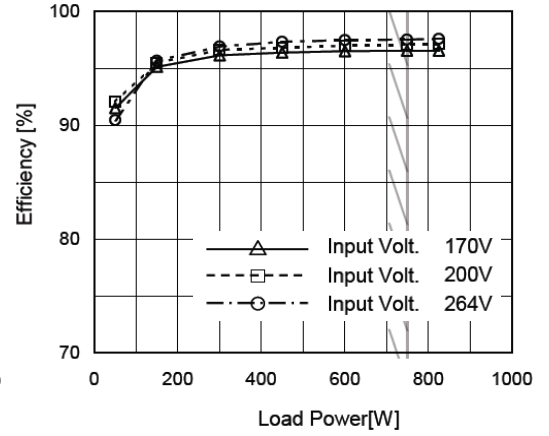
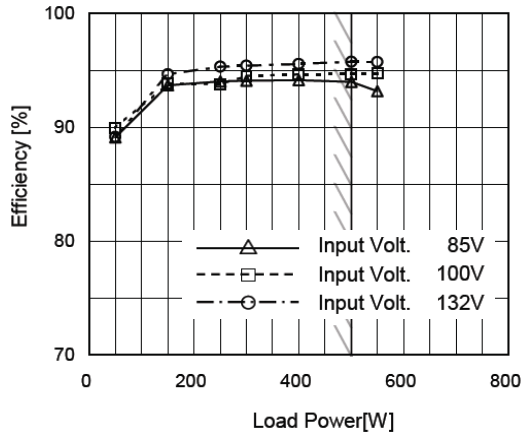

Fig. 1.8
Pin configuration
(bottom view)

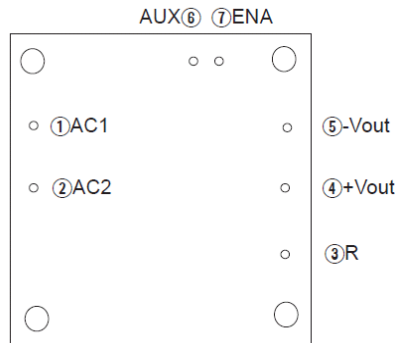
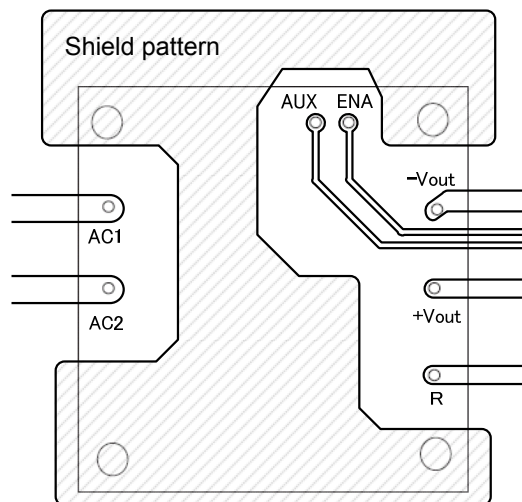

Table. 1.1
Pin configuration and
function

No.	Pin Connection	Function
①	AC1	AC Input
②	AC2	
③	R	External resistor for inrush current protection
④	+VOUT	+DC output
⑤	-VOUT	-DC output
⑥	AUX	Auxiliary power supply for external signal
⑦	ENA	Enable signal

Fig.1.9
Example of
shield pattern
(bottom view)



***CAUTION**
In UL60950, Shield patterns(FG) have to separate with other patterns.

- AC-FG : 3.2mm(min)
- Vout-FG : 4mm(min)

■ High-frequency noise radiates directly from the unit to the atmosphere. Therefore, design the shield pattern on the printed circuit board and connect its one to FG. The shield pattern prevents noise radiation.

2 Connection for standard use

- DPG must be used with some external components (fuse, noise filter, inrush current limiting resistor and heat sink).
- Use the DPG as shown in Fig.2.1 for applications.
- DPG is non-isolated between input and output.
- The power supply adopts the conduction cooling system. Attach a heat sink onto the aluminum base plate to cool the power module for use.

Fig.2.1
Example of connection
circuit, DPG

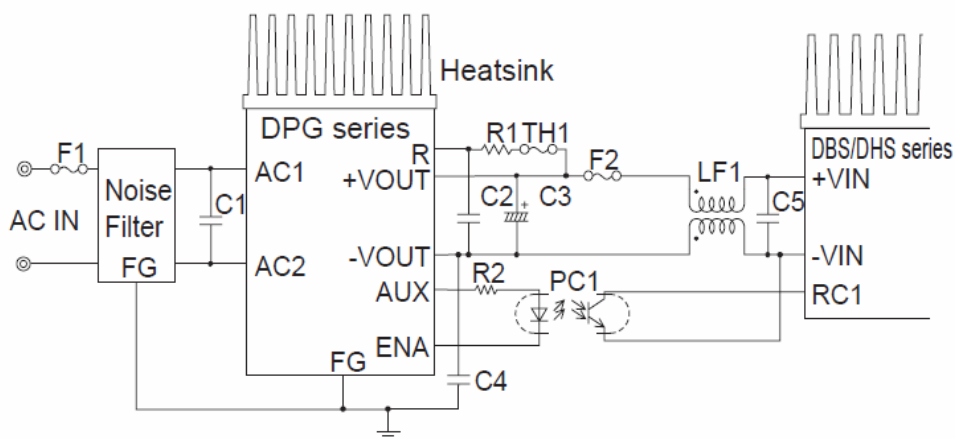

3 Wiring input / output pin

3.1 Wiring input pin

(1) Input fuse F1

- Fuse is not built-in at input side. In order to secure the safety of the unit, use the slow-blow type fuse as shown in Table 3.1 on the input line.
- When two or more units are used, such as a parallel operation, install a fuse for each unit.

Table.3.1
Input fuse
for DPG

No.	Symbol	Component	Required characteristics
①	F1	Input fuse	15A or less Slow-blow type
②	F2	Output fuse	10A or less Normal-blow type

(2) Noise filter NF1

- Noise filter is not built-in at input side. Install an external noise filter to reduce the line-noise and to keep stable operation of the module.
- Install a correspondence filter as shown in Fig.3.1, if a EMI standard is required.

Fig.3.1
Recommended filter
for DPG

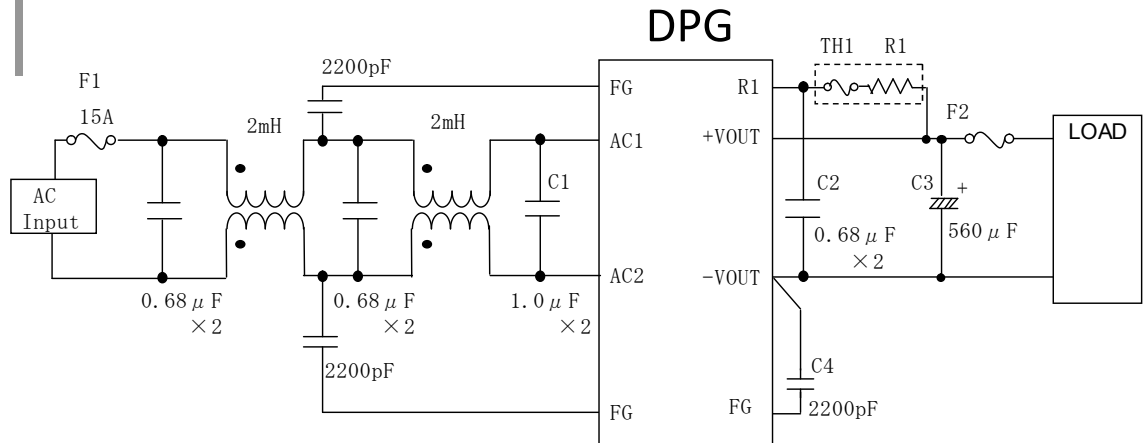

(3) External capacitor on the input side C1

- Install an external capacitor C1 to reduce the line-noise and to keep stable operation of the module. Use a film capacitor with rated AC250V to meet the safety standards. Recommended capacitance of C1 is 2μF or more, Rated ripple current : 5A or more, Film capacitor

3.2 Wiring output pin

(1) External capacitor on the output side C2

- Install an external capacitor C2 as close as possible to the output pins for stable operation of the module. Use a film capacitor with rated over DC400V. Recommended capacitance of C2 is 1μF or more, Rated ripple current : 4A or more, Film capacitor

(2) Decoupling capacitor C4

- Install a decoupling capacitor C4 more than 2200pF, as close as possible to the output pins for stable operation of the module. Use the Y capacitor with rated AC250V to meet the safety standards.

(3) Holdup capacitor C3

- DPG do not provide holdup capacitor. Connect the electrolytic capacitor near the output pins. Follow the guidelines below to select an electrolytic capacitor with an appropriate capacitance and ripple current rating considering the output ripple voltage, holdup time and life.

- The capacity should be with in 220-2200 μ F.

i Design procedure of holdup capacitor

1) Output ripple voltage

Obtain the required capacity from the output ripple voltage.

Make sure that the output ripple voltage is less than 15Vp-p.

$$C_o \geq \frac{P_o}{2 \pi f \times V_{rpl} \times V_o} \quad \cdot \cdot \cdot \cdot \cdot \quad (1)$$

C_o : Capacitance of the holdup capacitor [F]

V_{rpl} : Output ripple voltage [Vp-p]

P_o : output power [W]

f : Input frequency (50Hz/60Hz) [Hz]

V_o : Output voltage [V]

2) Holdup time

Obtain the required capacity from the holdup time required for the system.

$$C_o \geq \frac{2 \times P_o \times T_h}{(V_o - V_{rpl}/2)^2 - V_{min}^2} \quad \cdot \cdot \cdot \quad (2)$$

C_o : Capacitance of the holdup capacitor [F]

T_h : Holdup time [S]

P_o : output power [W]

V_o : Output voltage [V]

V_{rpl} : Output ripple voltage [Vp-p]

V_{min} : Minimum input voltage of DC-DC converter [V]

3) Ripple current

Obtain the required capacity from the holdup time required for the system.

(3) to calculate the total ripple current. Use a capacitor with the ripple current rating above the resulting value. Since the correction factor of allowable ripple current frequency (K) varies depending on the capacitor, check the exact value in the catalog of the capacitor.

$$I_r = \sqrt{I_L^2 + (I_H / K)^2} \quad \cdot \cdot \cdot \cdot \cdot \quad (3)$$

I_r : Ripple current flowing into the holdup capacitor [Arms]

I_L : Low frequency ripple current [Arms]

I_H : High frequency ripple current [Arms]

K : Correction factor of the allowable ripple current frequency

4) Selection of electrolytic capacitor

Use the electrolytic capacitor which meets the capacitance calculated in (1) and (2) above and the ripple current rating obtained in (3). When selecting the electrolytic capacitor, take into consideration the tolerance of the capacitor. Note that an electrolytic capacitor has a limited lifetime. The lifetime of the electrolytic capacitor is determined by the capacitor temperature, which can be estimated by the formula (4) below. To improve the reliability of the system, select an electrolytic capacitor which has a long enough lifetime (Lo).

$$(T_o - T_x) / 10$$

$$L_x = L_o \times 2 \quad \cdot \cdot \cdot \cdot \cdot \cdot \cdot \cdot \quad (4)$$

L_x : Expected life time [H]

L_o : Guaranteed lifetime of the electrolytic capacitor [H]

T_o : Maximum rated operating temperature Lo [°C]

T_x : Electrolytic capacitor temperature for use [°C]

4 Function

4.1 Protection circuit

(1) Overcurrent protection

- The overcurrent protection circuit is not built-in.

(2) Overvoltage protection

- The overvoltage protection circuit is built-in.

The AC input should be shut down if overvoltage protection is in operation.

When this function operates, the power factor corrector function does not operate, and output voltage becomes the full-wave rectified AC input voltage.

● Remarks :

Please note that the unit's internal components may be damaged if excessive voltage (over rated voltage) is applied to output terminal of power supply. This could happen when the customer tests the overvoltage protection of the unit.

(3) Thermal protection

- Thermal protection circuit is built-in and it works about 115°C. at base plate.

When this function operates, the power factor corrector function does not operate, and output voltage becomes the full-wave rectified AC input voltage.

- When this function is activated, input voltage should be turned and remove all possible causes of overheating, and cool down the temperature to normal level. To prevent the unit from overheating, avoid using the unit in a dusty, poorly ventilated environment.

4.2 Control signals

(1) Enable signal (ENA)

- Use ENA to control starting of the loaded power supply.
- When inrush current protection circuit is released, ENA outputs "LOW" .
- If load current flows without releasing of the circuit, the resistor may be burnt.
- If load current flows without releasing of the circuit, the resistor may be burnt.

Table.4.1
Specification of
ENA pin

No.	Item	ENA
1	Function	Output passible "L"
		Output prohibited "H"
2	Base pin	-Vout
3	Level voltage "L"	0.6V max at 10mA
4	Level voltage "H"	Open drain
5	Maximum sink current	10mA max
6	Maximum applied voltage	35V max

(2) Auxiliary power supply circuit for external signal (AUX)

- The AUX pin can be used as the power source with the open collector output for ENA.
- Shortprotection resistance ($2.2k\Omega$) is built in.
Outout voltage decreases as the output current increases.
- Never let a short circuit occur between the AUX pin and other pins. It may damage the unit.

Fig.4.1
AUX circuit

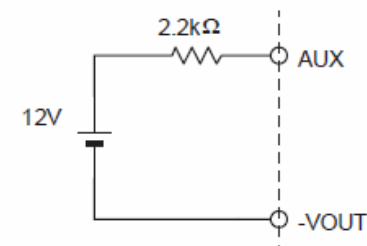

4.3 Others

(1) Isolation

- For a receiving inspection, such as Hi-Pot test, gradually increase (decrease) the voltage for a start (shut down). Avoid using Hi-Pot tester with the timer because it may generate voltage a few times higher than the applied voltage, at ON/OFF of a timer.

5 Series and parallel operation

5.1 Series operation

- As input and output are not isolated, series operation is not possible.

5.2 Parallel operation

- Parallel operation is not possible.

6 EMI

- The recommended circuit to meet noise standard EN55022/87.
- The noise may vary greatly, depending on the implementation, being affected by the stray capacity, wiring inductance and leakage flux. Check if the noise filter is appropriate on the final product.

Fig.6.1
Recommended filter

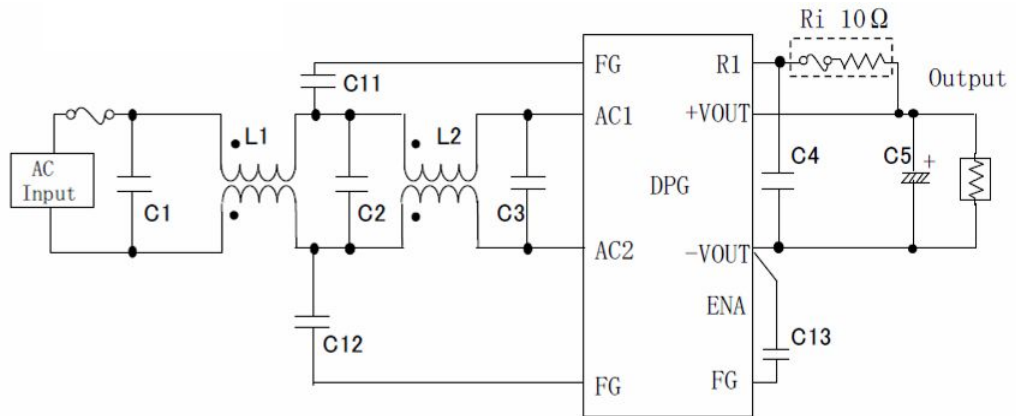

- C1,C2 : 0.68uF 250V Film Capacitor ×2
- C3 : 1.0uF 250V Film Capacitor ×2
- C4 : 0.68uF 400V Film Capacitor ×2
- C5 : 560uF 450V Electrolytic Capacitor ×2
- C11,C12,C13 : 2200pF Ceramic Capacitor
- L1,L2 : SC-15-200(NEC TOKIN)

Fig.6.2
Noise level (DPG750)

