

---

# COSEL

## Applications Manual of DHS series



# Contents

	Page
<b>1. Pin configuration</b>	A-1
<b>2. Do's and Don'ts for module</b>	A-2
2.1 Isolation	A-2
2.2 Mounting method	A-2
2.3 External input capacitor	A-3
2.4 Stress onto the pins	A-3
2.5 Cleaning	A-4
2.6 Soldering	A-4
2.7 Safety standard	A-4
<b>3. Connection method for use</b>	A-4
3.1 Connection for standard for use	A-4
3.2 Input power source	A-5
3.3 External fuse	A-6
3.4 Primary Y capacitor CY	A-6
3.5 External capacitor on the input side Cin	A-6
3.6 External capacitor on the output side Co	A-6
3.7 Thermal considerations	A-7
<b>4. Protect circuit</b>	A-7
4.1 Overvoltage protection	A-7
4.2 Overcurrent protection	A-7
4.3 Thermal protection	A-7
<b>5. Adjustable voltage range</b>	A-8
5.1 Output voltage adjusting method by external potentiometer(DHS50/100)	A-8
5.2 Output voltage adjusting method by external potentiometer(DHS200/250)	A-9
5.3 Output voltage decreasing by external resistor(DHS200/250)	A-9
5.4 Output voltage increasing by external resistor(DHS200/250)	A-10
5.5 Adjusting method by external voltage(DHS200/250)	A-10
<b>6. Remote ON/OFF</b>	A-11
<b>7. Remote sensing</b>	A-11
7.1 When the remote sensing function is in use	A-11
7.2 When the remote sensing function is not in use	A-12
<b>8. Series operation</b>	A-12
<b>9. Redundant operation</b>	A-12
<b>10. EMC consideration</b>	A-13
10.1 Line conducted noise	A-13
10.2 Radiated noise	A-17
10.3 Output noise	A-17
<b>11. Derating</b>	A-20
11.1 Cooling	A-20
<b>12. Thermal curve</b>	A-20
12.1 Measuring environment	A-21
12.2 Thermal curve	A-21
<b>13. Heat sink size and Thermal resistance</b>	A-24

## 1. Pin configuration

Fig. 1.1  
Pin configuration  
(bottom view)

### ● DHS50/100

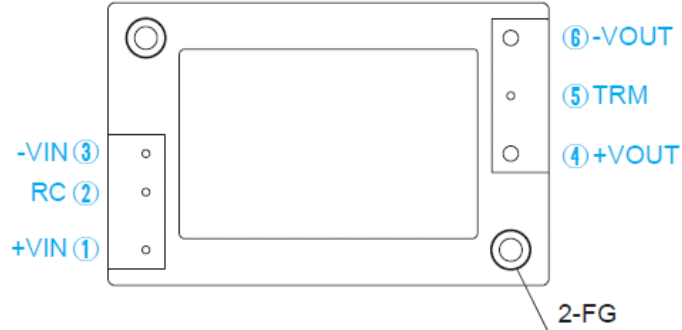

### ● DHS200/250

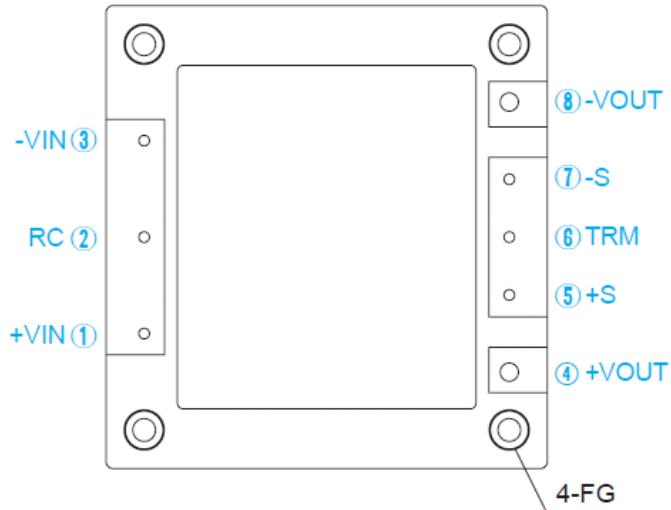

Table 1.2  
Pin configuration and  
function

Pin No.		Pin name	Function	Reference
DHS50 DHS100	DHS200 DHS250			
①	①	+VIN	+DC input	3.1 "Wiring input pin"
②	②	RC	Remote ON/OFF	4.4 "Remote ON/OFF"
③	③	-VIN	-DC input	3.1 "Wiring input pin"
④	④	+VOUT	+DC output	3.2 "Wiring output pin"
-	⑤	+S	+Remote sensing	4.5 "Remote sensing"
⑤	⑥	TRM	Adjustment of output voltage	4.6 "Adjustable voltage range"
-	⑦	-S	-Remote sensing	4.5 "Remote sensing"
⑥	⑧	-VOUT	-DC output	3.2 "Wiring output pin"
-	-	FG	Mounting hole	6.1 "Mounting method"

## 2 Do's and Don'ts for module

### 2.1 Isolation

- For receiving inspection, such as Hi-Pot test, gradually increase (decrease) the voltage for start (shut down). Avoid using Hi-Pot tester with the time because it may generate voltage a few times higher than the applied voltage, at ON/OFF of a timer.

### 2.2 Mounting method

- The unit can be mounted in any direction. When two or more power supplies are used side by side, position them with proper intervals to allow enough air ventilation. Aluminum base plate temperature around each power supply should not exceed the temperature range shown in derating curve.
- Avoid placing the DC input line pattern lay out underneath the unit, it will increase the line conducted noise. Make sure to leave an ample distance between the line pattern lay out and the unit. Also avoid placing the DC output line pattern underneath the unit because it may increase the output noise. Lay out the pattern away from the unit.
- High-frequency noise radiates directly from the unit to the atmosphere. Therefore, design the shield pattern on the printed circuit board and connect its one to FG. The shield pattern prevents noise radiation. Fig. 2.1 Examples of parallel operation when output voltage adjustment is not in use. TRM wiring, R1, R2 and VR are not necessary.

Fig. 2.1  
Shield pattern lay out  
(bottom view)

●DHS50/100

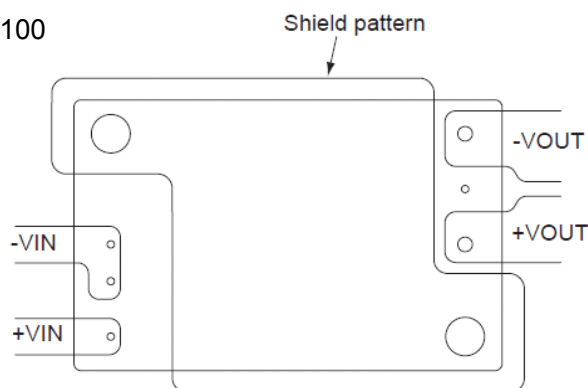

●DHS200/250

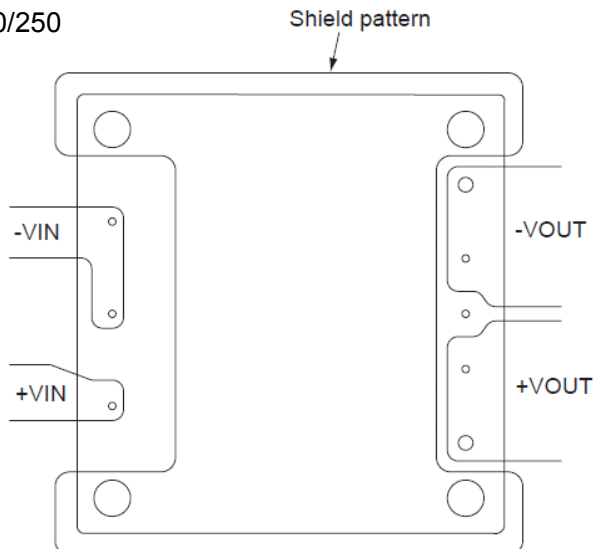

## 2.3 External input capacitor

- When the line impedance is high or the input voltage rise quickly at start-up (less than 10 $\mu$ s), install capacitor  $C_{in}$  between +VIN and -VIN input pins (within 50mm from pins).

Fig. 2.2  
External input capacitor

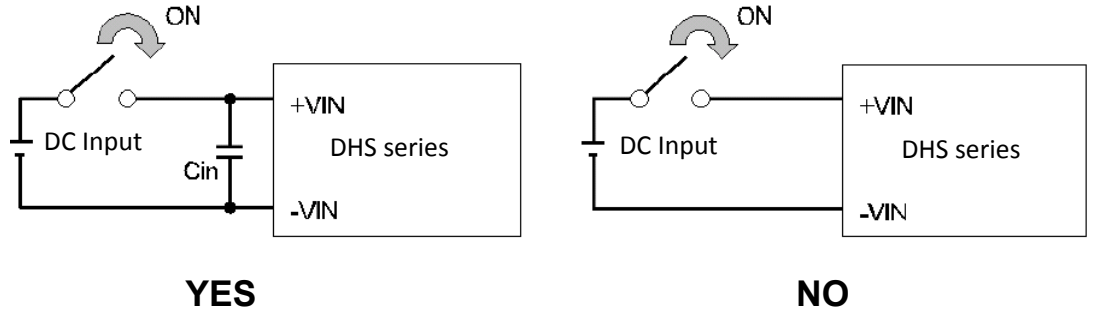

DHS50A/100A	: 22 $\mu$ F
DHS200A	: 47 $\mu$ F
DHS50B/100B	: 10 $\mu$ F
DHS250B	: 22 $\mu$ F

## 2.4 Stress onto the pins

- When too much stress is applied to the pins of the power supply, the internal connection may be weakened. As shown in Fig. 2.3 avoid applying stress of more than 29.4N (3kgf) on the +VOUT pin/-VOUT pins and more than 9.8N (1kgf) to the signal pins.
- The pins are soldered on PCB internally, therefore, do not pull or bend them with abnormal forces.
- Fix the unit on PCB (fixing fittings) to reduce the stress onto the pins.

Fig. 2.3  
Stress onto the pin

•DHS50/100

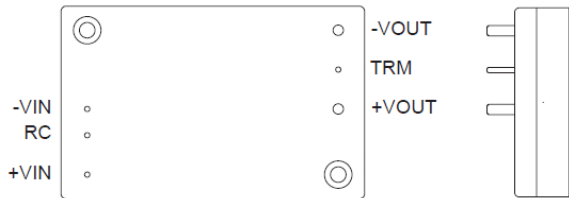

•DHS200/250

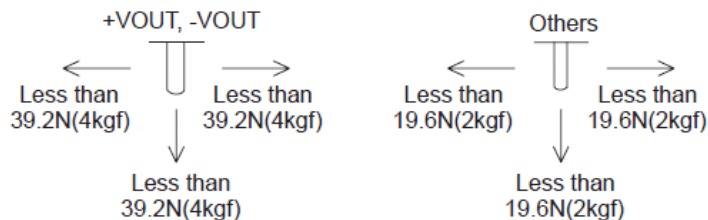
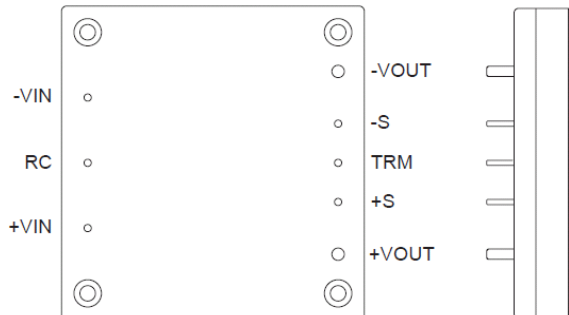

## 2.5 Cleaning

- Clean it with a brush. Prevent fluid from getting inside the unit.
- Do not apply pressure to the lead and name plate with a brush or scratch it during the cleaning.
- After cleaning, dry them enough.

## 2.6 Soldering

- Flow soldering: 260C for up to 15 seconds.
- Soldering iron (26W): 450C for up to 5 seconds.

## 2.7 Safety standard

- This unit must be used as a component of the end-use equipment.
- This unit must be provided with overall enclosure.
- Mounting holes must be connected to safety ground of the end-use equipment, as required for class I equipment.
- Input must be filtered and rectified.
- Safety approved fuse must be externally installed on input side.

# 3 Connection method for use

## 3.1 Connection for standard for use

- In order to use the power supply, it is necessary to wire as shown in Fig. 3.1.
  - Short the following pins to turn on the power supply.
    - VIN ⇔ RC1
    - +VOUT ⇔ +S, -VOUT ⇔ -S (DHS200/250)
- Reference : 6. Remote ON/OFF  
 7. Remote sensing

Fig. 3.1  
 Connection for  
 standard use

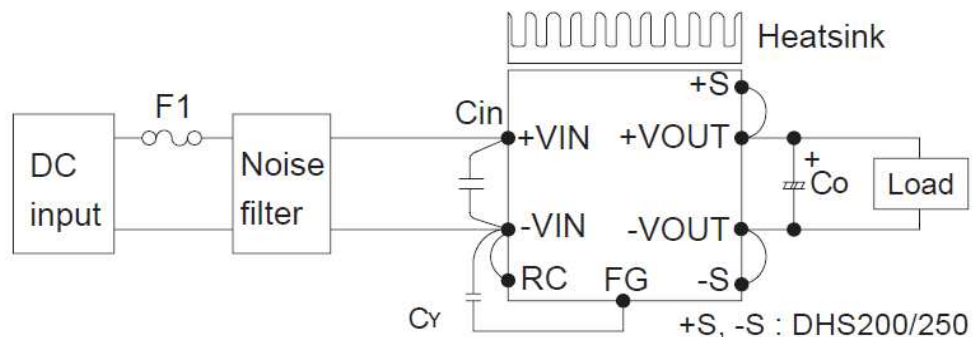

- Cin : External capacitor on the input side
- Co : External capacitor on the output side
- Cy : Primary decoupling capacitor

### 3.2 Input power source

#### (1) Operation with DC input

■ The specification of input ripple voltage is shown as below.

Ripple voltage	DHS50A/100A/200A : less than 10Vp-p
	DHS50B/100B/250B : less than 20Vp-p

■ Make sure that the voltage fluctuation, including the ripple voltage, will not exceed the input voltage range.

■ Use a front-end unit with enough power, considering the start-up current  $I_p$  of this unit.

Fig. 3.2  
Input voltage ripple

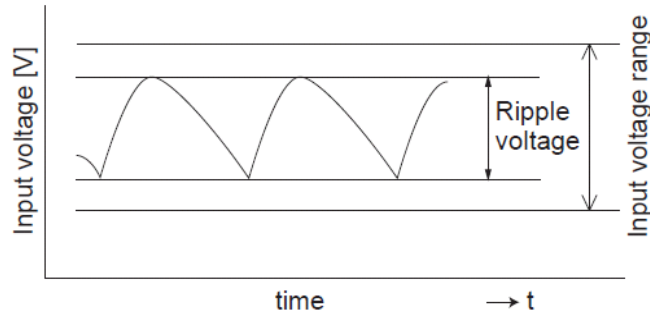
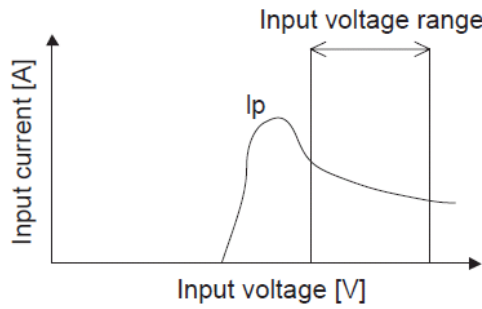

Fig. 3.3  
Input current characteristics



#### (2) Operation with AC input

■ The DHS series handles only for the DC input. A front-end unit (AC/DC unit) is required when the DHS series is operated with AC input. In detail, Refer to 5. Input circuit.

Fig. 3.4  
Operation with AC input

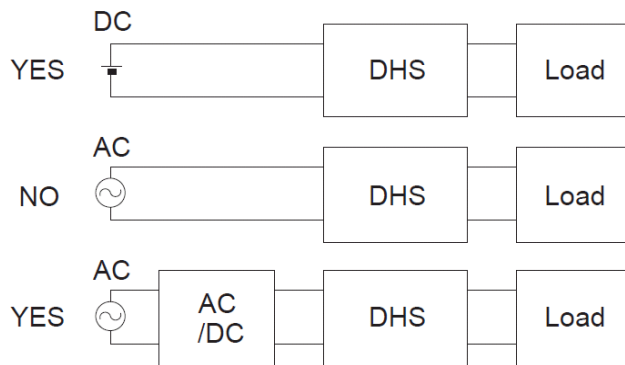

#### (3) Reverse input voltage protection

Avoid the reverse polarity input voltage. It will break the power supply. It is possible to protect the unit from the reverse input voltage by installing an external diode.

Fig. 3.5  
Reverse input voltage protection

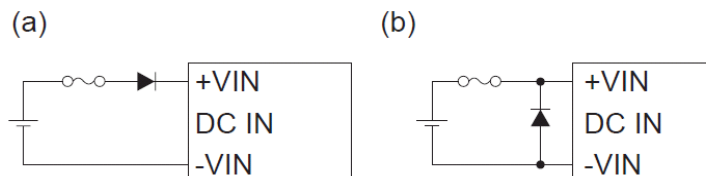

### 3.3 External fuse

- Fuse is not built-in on input side. In order to protect the unit, install the normal-blow type fuse on input side.
- When the input voltage from a front end unit is supplied to multiple units, install a normal-blow type fuse in each unit.

Table 3.6  
Recommended fuse  
(normal-below type)

MODEL	DHS50A DHS100A	DHS200A	DHS50B DHS100B	DHS250B
Rated current	3.15A	5A	1.6A	3.15A

### 3.4 Primary Y capacitor $C_Y$

- Install an external noise filter and a Y capacitor for low line-noise and for stable operation of the power supply.
- Install a correspondence filter, if a noise standard meeting is required or if the surge voltage may be applied to the unit.
- Install a primary Y capacitor, with more than 470pF, near the input pins (within 50mm from the pins).
- When the total capacitance of the primary Y capacitor is more than 8800pF, the nominal value in the specification may not be met by the Hi-Pot test between input and output. In this case, a capacitor should be installed between output and FG.

### 3.5 External capacitor on the input side $C_{in}$

- Install an external capacitor in between +VIN and -VIN input pins for low line-noise and for stable operation of the power supply.

(	$C_{in}$ DHS50A/100A	: more than 22 $\mu$ F
	DHS200A	: more than 47 $\mu$ F
	DHS50B/100B/250B	: more than 0.1 $\mu$ F

- $C_{in}$  is within 50mm from pins. Make sure that ripple current of  $C_{in}$  should be less than rate.

### 3.6 External capacitor on the output side $C_o$

- Install an external capacitor  $C_o$  between +VOUT and -VOUT pins for stable operation of the power supply.  
Recommended capacitance of  $C_o$  is shown in Table 3.7.
- Select the high frequency type capacitor. Output ripple and start-up waveform may be influenced by ESR/ ESL of the capacitor and the wiring impedance.
- When output current change sharply, make sure that ripple current of  $C_o$  should be less than rating.
- Install a capacitor  $C_o$  near the output pins (within 100mm from the pins).

Table 3.7  
Recommended fuse  
(normal-below type)

Model  Output voltage (v)	Temperature of Base plate			
	Tbp = 0 ~ +100°C		Tbp = -40 ~ +100°C	
	DHS50/100	DHS200/250	DHS50/100	DHS200/250
3.3V	2200 $\mu$ F	2200 $\mu$ F	2200 $\mu$ FX3	2200 $\mu$ FX3
5V	2200 $\mu$ F	2200 $\mu$ F	2200 $\mu$ FX3	2200 $\mu$ FX3
7.5V	-	2200 $\mu$ F	-	2200 $\mu$ FX3
12V	470 $\mu$ F	1000 $\mu$ F	470 $\mu$ FX3	1000 $\mu$ FX3
15V	470 $\mu$ F	1000 $\mu$ F	470 $\mu$ FX3	1000 $\mu$ FX3
24V	220 $\mu$ F	470 $\mu$ F	220 $\mu$ FX3	470 $\mu$ FX3
28V	220 $\mu$ F	470 $\mu$ F	220 $\mu$ FX3	470 $\mu$ FX3
48V	-	330 $\mu$ F	-	330 $\mu$ FX3

### 3.7 Thermal considerations

---

- Operate with the conduction cooling (e.g. heat radiation from the aluminum base plate to the attached heat sink).
- Reference : 8. Thermal considerations

## 4 Protect circuit

### 4.1 Overvoltage protection

---

- The overvoltage protection circuit is built-in. The DC output should be shut down if overvoltage protection is activated. The minimum interval of DC ON/OFF for recovery is for 2 to 3 minutes.

\* The recovery time depends on input voltage and input capacity.

◆Remarks :

Please note that devices inside the power supply might fail when voltage more than rated output voltage is applied to output terminal of the power supply. This could happen when the customer tests the overvoltage protection of the unit.

### 4.2 Overcurrent protection

---

- Overcurrent protection is built-in and activated at over 105% of the rated current. The unit automatically recovers when the fault condition is removed.

- Intermittent operation

When the overcurrent protection is activated, the average output current is reduced by intermittent operation of power supply to reduce heat of load and wiring.

### 4.3 Thermal protection

---

- Thermal protection circuit are built-in.
- When this function is activated, input voltage should be turned off, and remove all possible causes of overheat condition and cool down the unit to the normal level temperature.
- Overheat protection works around 110°C at the base plate.

## 5 Adjustable voltage range

- Output voltage is adjustable by the external potentiometer or the external signal.
- When the output voltage adjustment is not used, leave the TRM pin open.
- Do not set output voltage over regulated, overvoltage protection might be activated.

### 5.1 Output voltage adjusting method by external potentiometer (DHS50/100)

- By connecting the external potentiometer (VR1) and resistors (R1, R2) more than 1/10W, output voltage becomes adjustable, as shown in Fig.1.6.5, recommended external parts are shown in Table 1.6.1.
- The wiring to the potentiometer should be as short as possible. The temperature coefficient becomes worse, depending on the type of a resistor and potentiometer. Following parts are recommended for the power supply.

Fig. 5.1  
Output voltage  
control circuit

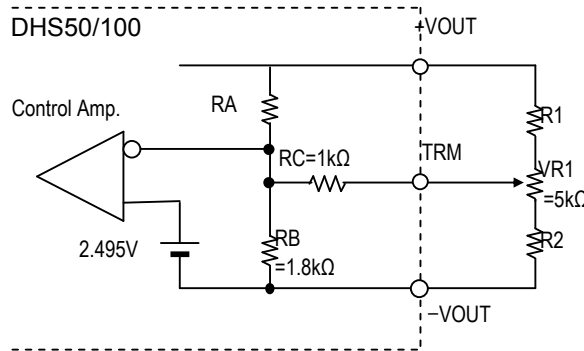

Table 5.2  
Recommended value  
of external  
potentiometer and  
resistors  
(more than 1/10W)

No.	Output Voltage	Adjustable Range			
		VOUT ±5%		VOUT ±10%	
		R1	R2	R1	R2
1	3.3V	5.1kΩ	3.3kΩ	3.3kΩ	2.2kΩ
2	5V	12kΩ		8.2kΩ	
3	12V	15kΩ		10kΩ	
4	15V	22kΩ		15kΩ	
5	24V	39kΩ		27kΩ	
6	28V	47kΩ		33kΩ	

## 5.2 Output voltage adjusting method by external potentiometer (DHS200/250)

- By connecting the external potentiometer (VR1) and resistors (R1, R2) more than 1/10W, output voltage becomes adjustable, as shown in Fig. 5.3, recommended external parts are shown in Table 5.4.
- The wiring to the potentiometer should be as short as possible. The temperature coefficient becomes worse, depending on the type of a resistor and potentiometer. Following parts are recommended for the power supply.

Fig. 5.3  
Output voltage  
control circuit

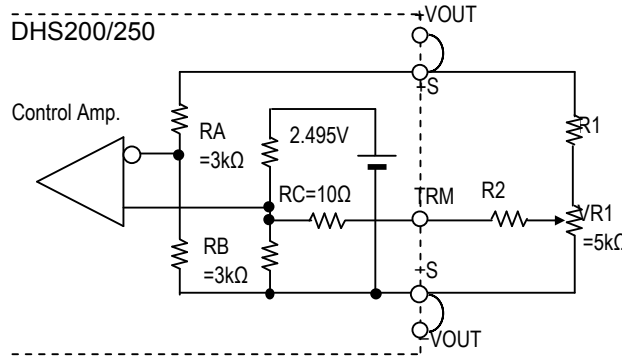

Table 5.4  
Recommended value  
of external  
potentiometer and  
resistors  
(more than 1/10W)

No.	Output Voltage	Adjustable Range			
		VOUT ± 5%		VOUT ± 10%	
		R1	R2	R1	R2
1	3.3V	2.4kΩ	12kΩ	2.4kΩ	8.2kΩ
2	5V	5.6kΩ		5.6kΩ	
3	7.5V	10kΩ		10kΩ	
4	12V	18kΩ		18kΩ	
5	15V	24kΩ		24kΩ	
6	24V	43kΩ		43kΩ	
7	28V	47kΩ		47kΩ	
8	48V	91kΩ		91kΩ	

## 5.3 Output voltage decreasing by external resistor (DHS200/250)

- By connecting the external resistor (R1) more than 1/10W, output voltage becomes adjustable to decrease as shown in Fig. 5.5.

Fig. 5.5  
Output voltage  
control circuit

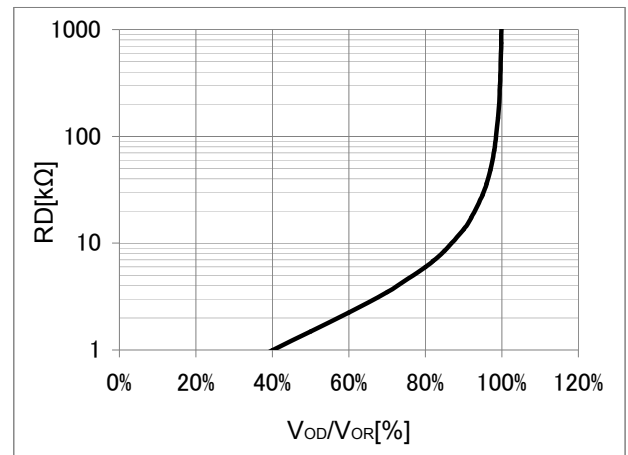
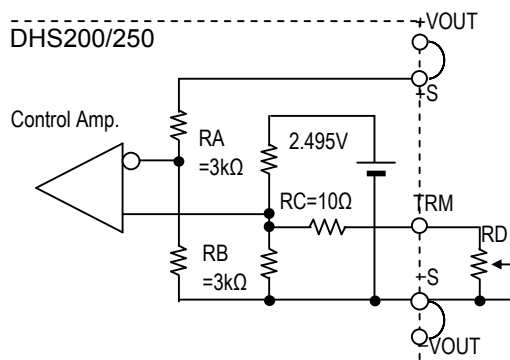

$$RD = \frac{1.51 \times \frac{V_{OD}}{V_{OR}} - 0.01}{1.0 - \frac{V_{OD}}{V_{OR}}} [k\Omega]$$

Output voltage is calculated by the following equation

V<sub>OR</sub> : Rated output voltage

V<sub>OD</sub> : Desire output voltage

## 5.4 Output voltage increasing by external resistor (DHS200/250)

- By connecting the external resistor (R1) more than 1/10W, output voltage becomes adjustable to increase as shown in Fig. 5.6.

Fig. 5.6  
Output voltage  
control circuit

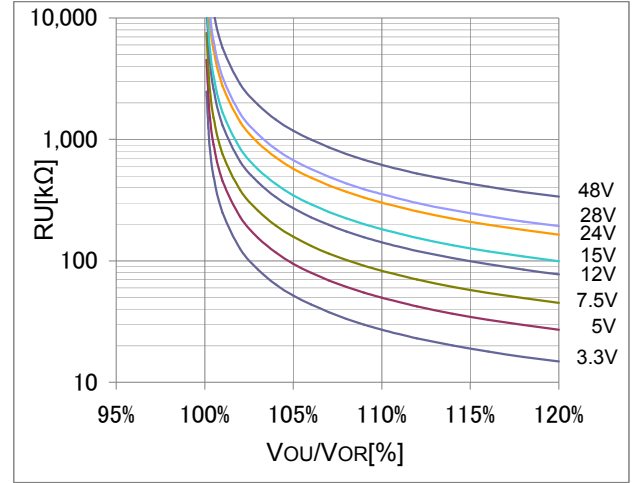
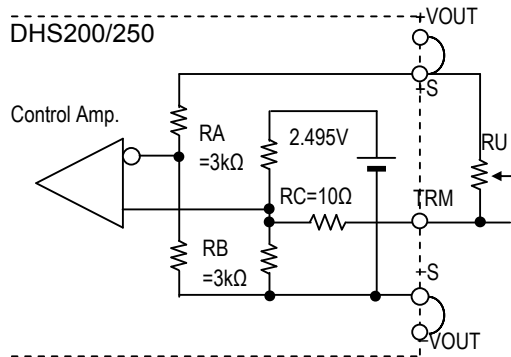

$$RU = \frac{\left[ 3.0 \times \frac{V_{OR}}{V_{ref}} - 1.51 \right] \times \frac{V_{OU}}{V_{OR}} + 0.01}{\frac{V_{OU}}{V_{OR}} - 1.0} [k\Omega]$$

Output voltage is calculated by the following equation

$V_{OR}$  : Rated output voltage

$V_{OU}$  : Desire output voltage

$V_{ref}$  : 2.495 [V]

## 5.5 Adjusting method by applying external voltage (DHS200/250)

By applying the voltage externally at TRM, output voltage becomes adjustable. Output voltage is calculated by the following equation.

Output voltage = (Applied voltage externally) x 1.2475 x (Rated output voltage)

## 6 Remote ON/OFF

- Remote ON/OFF circuit is built-in on input side.

Table. 6.1  
Remote ON/OFF

ON/OFF logic	Between RC and -VIN	Output voltage
Negative	"L" level (0 - 1.2V) or short	ON
	"H" level (3.5 - 7.0V) or open	OFF

- When RC is "Low" level, Sink current is 0.5mA typ. When Vcc is applied, use 3.5 ~ 7V. When remote ON/OFF function is not used, please short between RC and -VIN

Fig. 6.2  
RC connection  
example

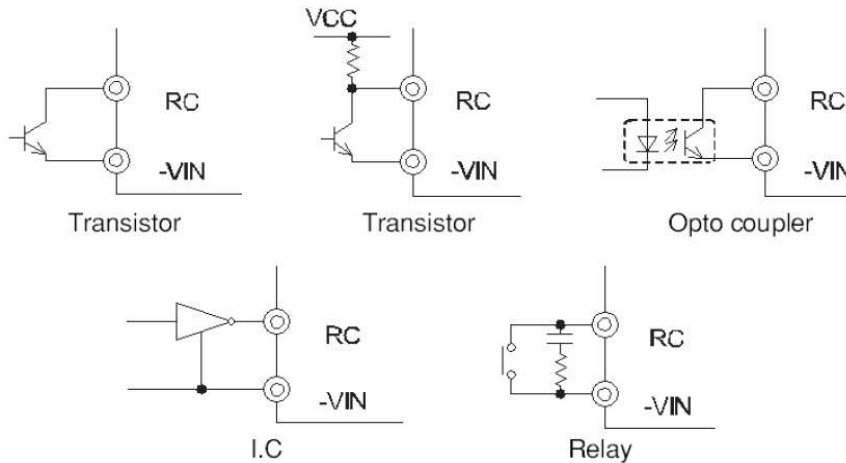

## 7 Remote sensing(DHS200/250)

- DHS200/250 has a Remote sensing function.
- This function compensate line voltage drop.

### 7.1 When the remote sensing function is in use

Fig. 7.1  
Connection when  
the remote sensing  
is in use

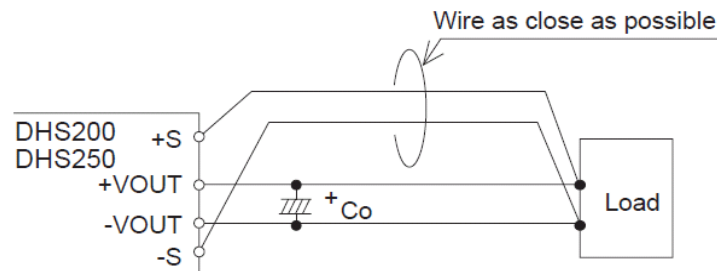

- Twisted-pair wire or shield wire is recommended be used for sensing wire.
- Thick wire should be used for wiring between the power supply and a load. Line drop should be less than 0.3V. Voltage between +VOUT and -VOUT should be remain within the output voltage adjustment range.
- If output voltage is trimmed down below 60% of the rated output voltage, ripple and noise will increase occasionally and/or over shoot occurs when start-up. External filter attach to the output is effective to reduce ripple and noise and remote ON/OFF is effective to avoid over shoot when start-up.
- Output voltage might become unstable because of impedance of wiring and load condition when length of wire is exceeding 2m.

## 7.2 When the remote sensing function is not in use

Fig. 7.2  
Connection when  
the remote sensing  
is not in use

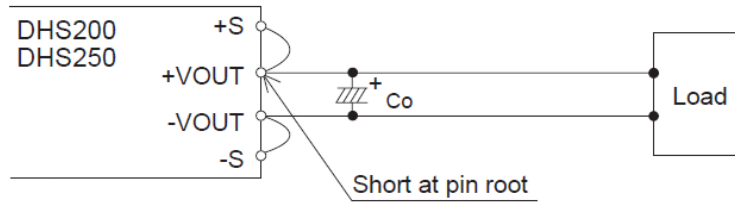

- When the remote sensing function is not in use, Make sure that pins are shorted between +S and +VOUT and between -S and -VOUT are connected.
- Connect between +S and +VOUT and between -S and -VOUT directly.  
No loop wiring.  
This power supply might become unstable by the noise coming from poor wiring.

## 8 Series operation

- Series operation is available by connecting the outputs of two or more power supplies, as shown Fig. 8.1. Output current in series connection should be lower than the lowest rated current in each power supply.

Fig. 8.1  
Examples of serial  
operation

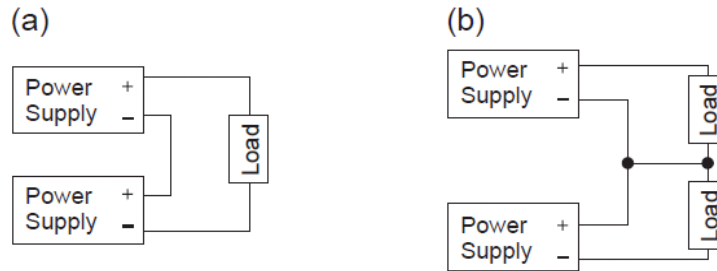

## 9 Redundant operation

- Parallel operation is not possible.  
Redundancy operation is available by connecting the units as shown Fig. 9.1.

Fig. 9.1  
Examples of redundant  
operation

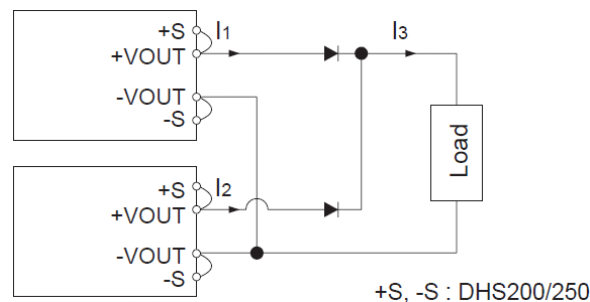

- Even a slight difference in output voltage can affect the balance between the values of I1 and I2.  
Please make sure that the value of I3 does not exceed the rated current.

$I_3$  must be less than a rated current value

## 10 EMC consideration

### 10.1 Line conducted noise

#### (1) Overview of the conducted noise

- The switch mode power supply generates the conducted noise to the input lines. The conducted noise can be categorized into the common mode noise and the differential mode noise.

- CISPR and FCC standards have been used as a world wide benchmark especially for line conducted interference levels.

If an EMI specification such as CISPR standard must be met, additional filtering may be needed.

The common mode noise exists between the input terminals and CASE pin.

The most effective way to reduce common mode noise are to bypass from the input lines to CASE pin with Y capacitor ( $C_Y$ ) and the common mode choke ( $L_1$ ).

Fig.2.11.1 shows the overview of the path of the common mode noise.

- The differential mode noise exists between the input terminals.

The most effective means to reduce differential mode noise are to bypass the input lines with X capacitors ( $C_{X3}$ ,  $C_{X4}$ ) and the normal mode choke ( $L_2$ ).

Fig.2.11.2 shows the overview of the path of the differential mode noise.

Fig. 10.1  
Common mode  
noise path

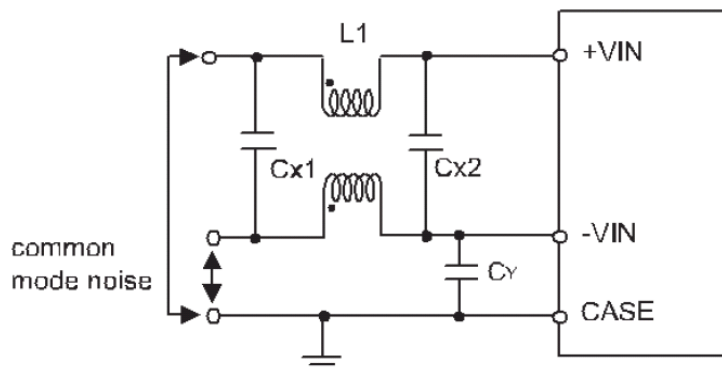
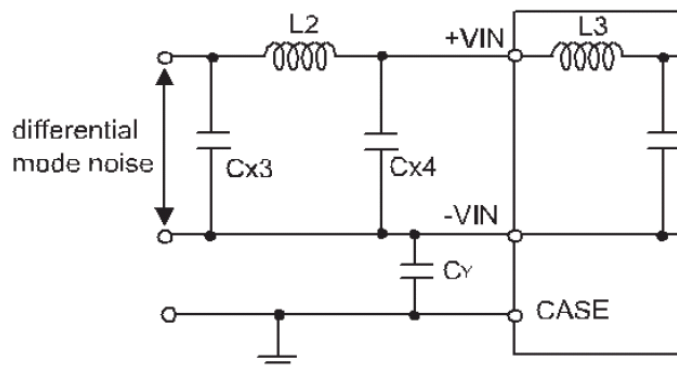

Fig. 10.2  
Differential mode  
noise path



- The DHS provide the normal mode choke ( $L_3$ ) to reduce the differential mode noise. Install the capacitor ( $C_{X4}$ ) to reduce the differential mode noise. The most effective way to reduce the differential mode noise are to install since X capacitor ( $C_{X3}$ ) and the normal mode choke ( $L_2$ ).
- The leakage inductance of the common mode choke ( $L_1$ ) works as the normal mode choke. The normal mode choke ( $L_2$ ) is not necessary.

(2) Recommended of noise-filter

■ Fig. 10.3 shows the recommended circuit of noise-filter which meets CISPR Pub. 22 Class A and the noise level.

DHS100A05 : AC90V INPUT, 5V20A OUTPUT

Fig. 10.3  
Recommended circuit  
and noise level  
CISPR Pub.22 Class A)

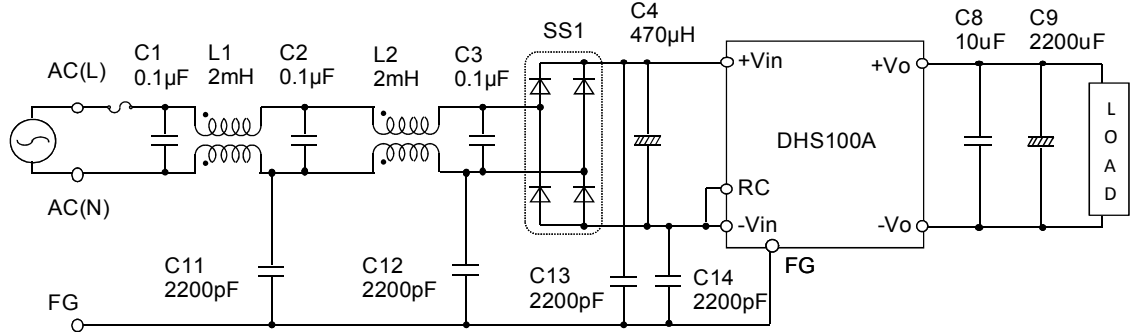

- L1,L2 : SC-05-200(NEC TOKIN)
- C1,C2,C3 : 0.1µF(CFJC22E104M:NITSUKO)
- C4 : 400V470µF(GU series : NICHICON)
- SS1 : D3SBA60(SINDENGEN)
- C8 : 50V10µF(Monolithic Ceramic Capacitors)
- C9 : 10V2200µF(LXZ series : NIPPON CHEMI-CON)
- C11~C14: AC250V2200pF(KH series : MURATA)

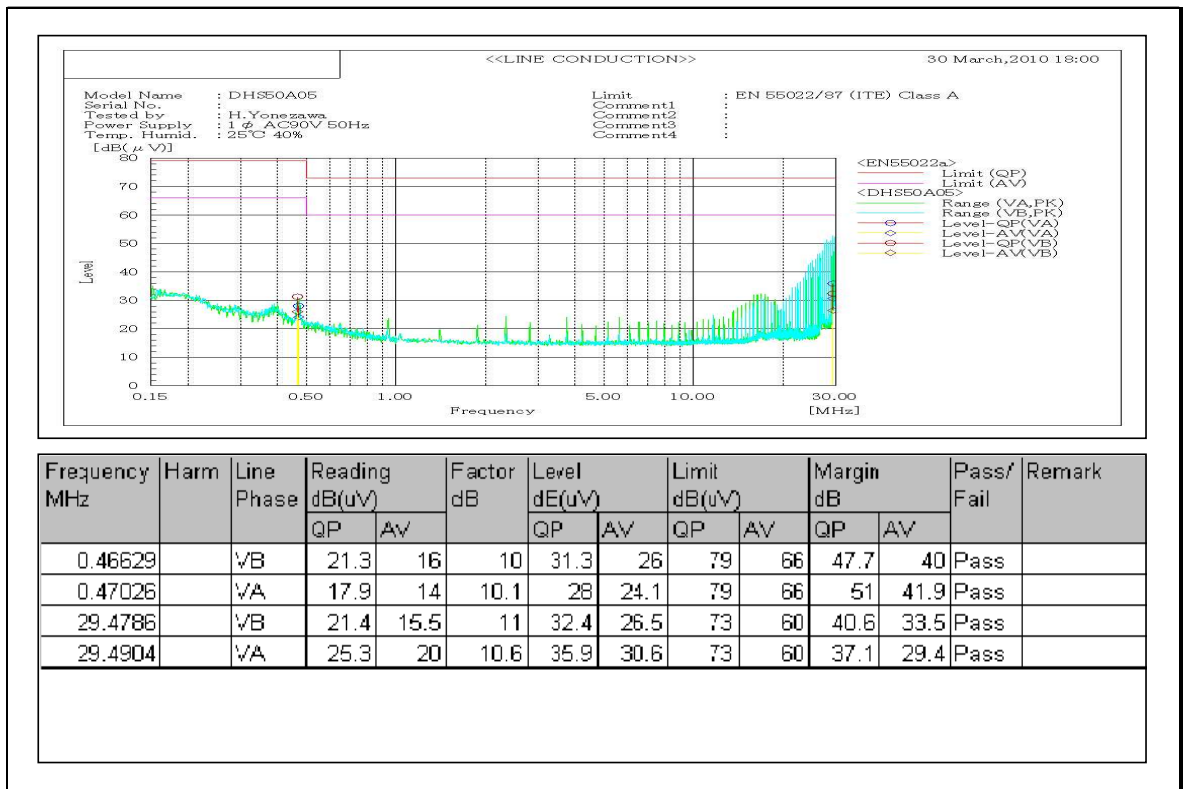

■ Fig. 10.4 shows the recommended circuit of noise-filter which meets CISPR Pub. 22 Class A and the noise level.

DHS100B05 : AC230V INPUT, 5V20A OUTPUT

Fig. 10.4  
Recommended circuit  
and noise level  
CISPR Pub.22 Class A)

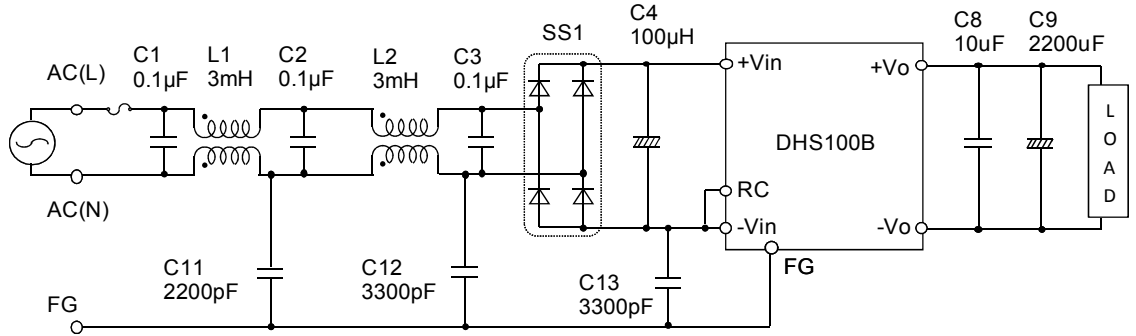

- L1,L2 : SC-05-300(NEC TOKIN)
- C1,C2,C3 : 0.1µF(CFJC22E104M:NITSUKO)
- C4 : 400V100µF(GU series : NICHICON)
- SS1 : D3SBA60(SINDENGEN)
- C8 : 50V10µF(Monolithic Ceramic Capacitors)
- C9 : 10V2200µF(LXZ series : NIPPON CHEMI-CON)
- C11 : AC250V2200pF(KH series : MURATA)
- C12,C13 : AC250V3300pF(KH series : MURATA)

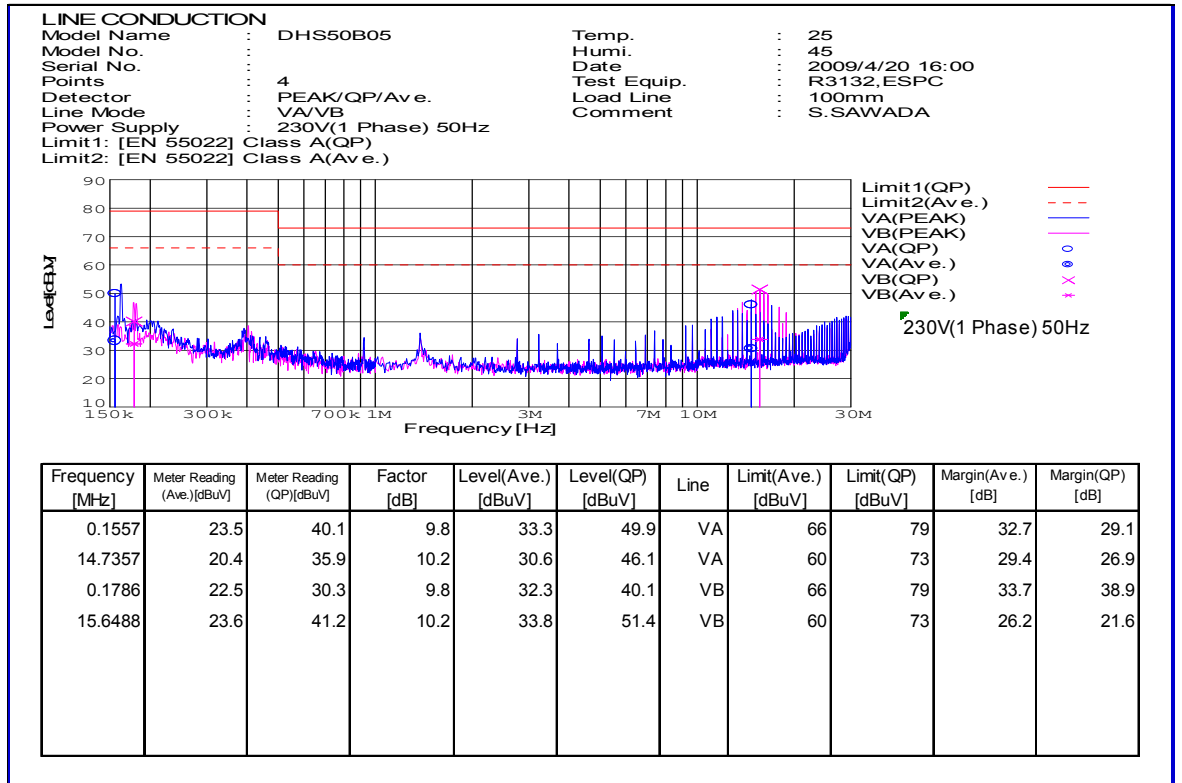

■ Fig. 10.5 shows the recommended circuit of noise-filter which meets CISPR Pub. 22 Class A and the noise level.

DHS250B24 : AC230V INPUT, 24V10.5A OUTPUT

Fig. 10.5  
Recommended circuit  
and noise level  
CISPR Pub.22 Class A)

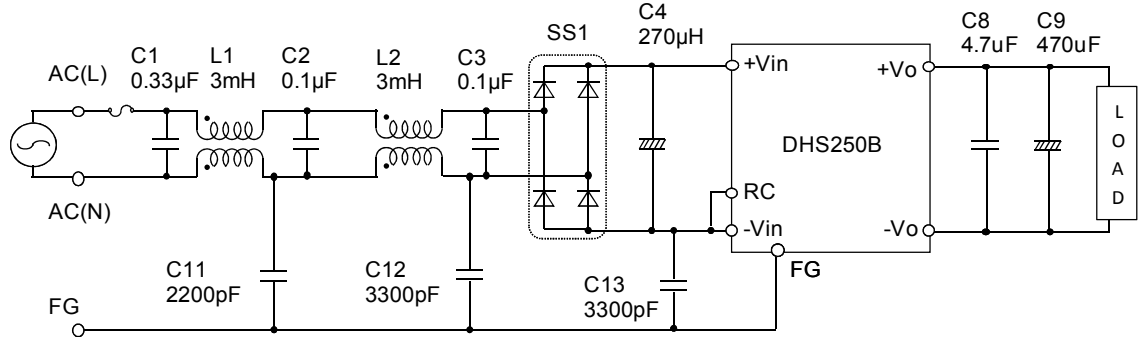

- L1,L2 : SC-05-300(NEC TOKIN)
- C1 : 0.33 $\mu$ F(CFJC22E334M:NITSUKO)
- C2,C3 : 0.1 $\mu$ F(CFJC22E104M:NITSUKO)
- C4 : 400V270 $\mu$ F(GU series : NICHICON)
- SS1 : D3SBA60(SINDENGEN)
- C8 : 50V4.7 $\mu$ F(Monolithic Ceramic Capacitors)
- C9 : 35V470 $\mu$ F(LXZ series : NIPPON CHEMI-CON)
- C11 : AC250V2200pF(KH series : MURATA)
- C12,C13 : AC250V3300pF(KH series : MURATA)

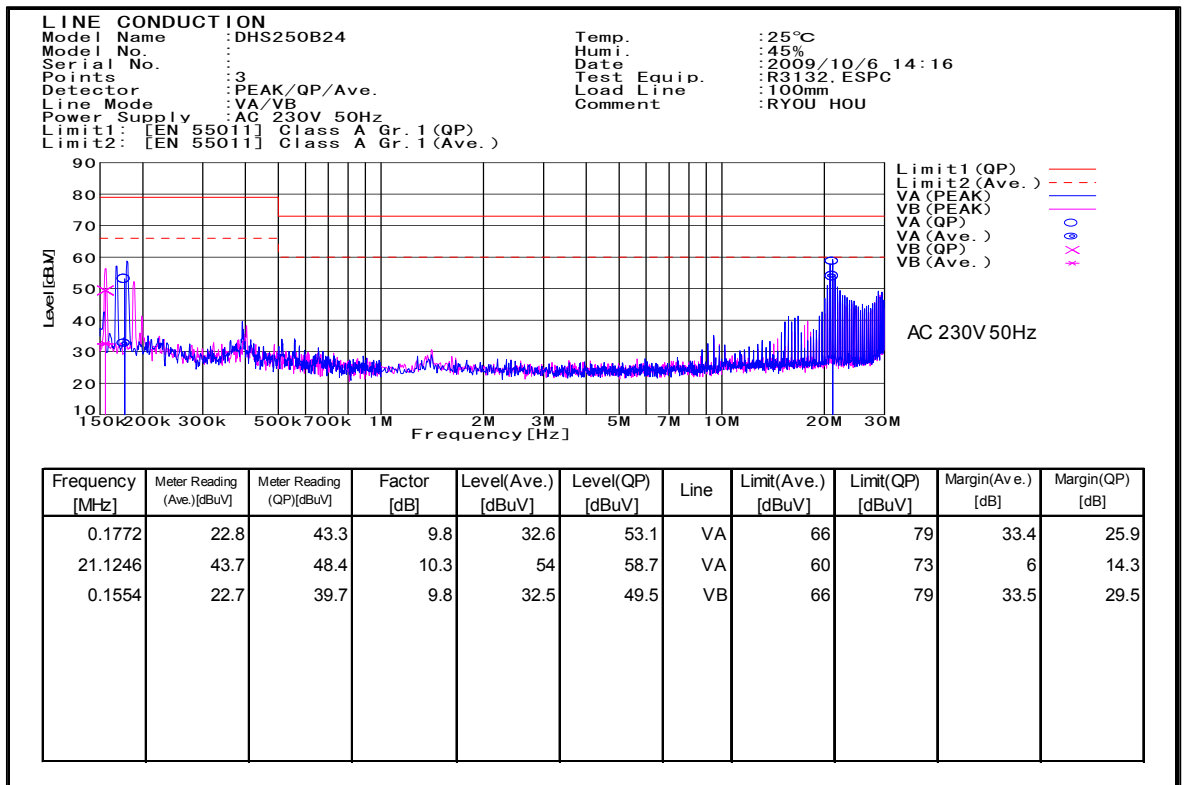

## 10.2 Radiated noise

- High-frequency noise is radiated directly from the module, the input lines and the output lines to the atmosphere.  
The noise-filter (EMC component) is required to reduce the radiated noise.
- The effective ways to reduce the radiated noise are to cover units with the metal plate or film.

## 10.3 Output noise

- Install an external capacitor  $C_o$  between +VOUT and -VOUT for stable operation and low output noise.  
Recommended capacitance of  $C_o$  is shown in Table 10.7.
- Install a capacitor  $C_1$  (ceramic capacitor) for low output high-frequency noise.
- Install a capacitor  $C_Y$ , with more than 2200pF, for stable operation and low output noise.

Fig. 10.6  
Measuring method of  
the output noise

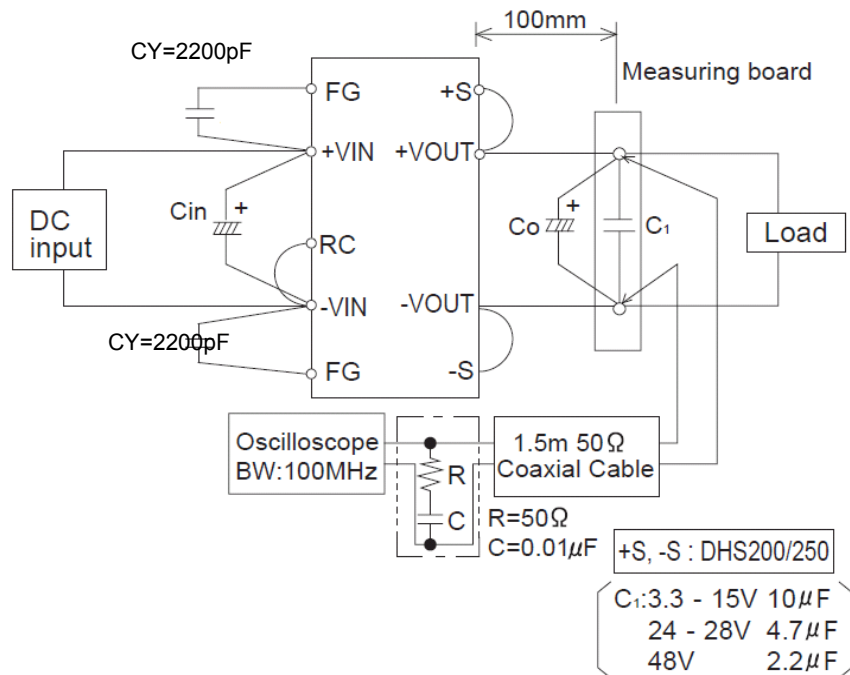
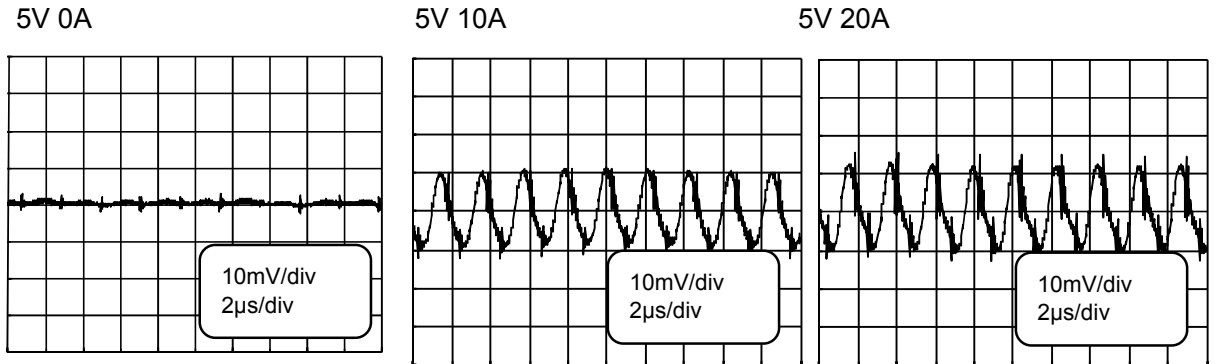

Table 10.7  
Measuring method of  
the output noise

Model	Temperature of Base plate			
	Tbp = 0 ~ +100°C		Tbp = -40 ~ +100°C	
	DHS50/100	DHS200/250	DHS50/100	DHS200/250
Output voltage (v)				
3.3V	2200μF	2200μF	2200μFX3	2200μFX3
5V	2200μF	2200μF	2200μFX3	2200μFX3
7.5V	-	2200μF	-	2200μFX3
12V	470μF	1000μF	470μFX3	1000μFX3
15V	470μF	1000μF	470μFX3	1000μFX3
24V	220μF	470μF	220μFX3	470μFX3
28V	220μF	470μF	220μFX3	470μFX3
48V	-	330μF	-	330μFX3

■ Fig. 10.8 show the output noise level.  
DHS100A05 : DC110V INPUT

Fig. 10.8  
Output noise



■ Fig. 10.9 show the output noise level.  
DHS100B05 : DC280V INPUT

Fig. 10.9  
Output noise

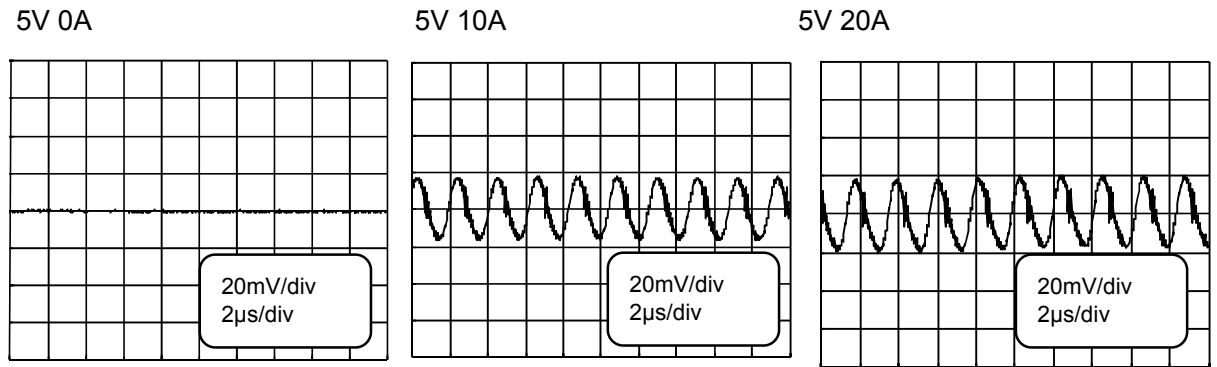

■ Fig. 10.10 show the output noise level.  
DHS250B24 : DC280V INPUT

Fig. 10.10  
Output noise

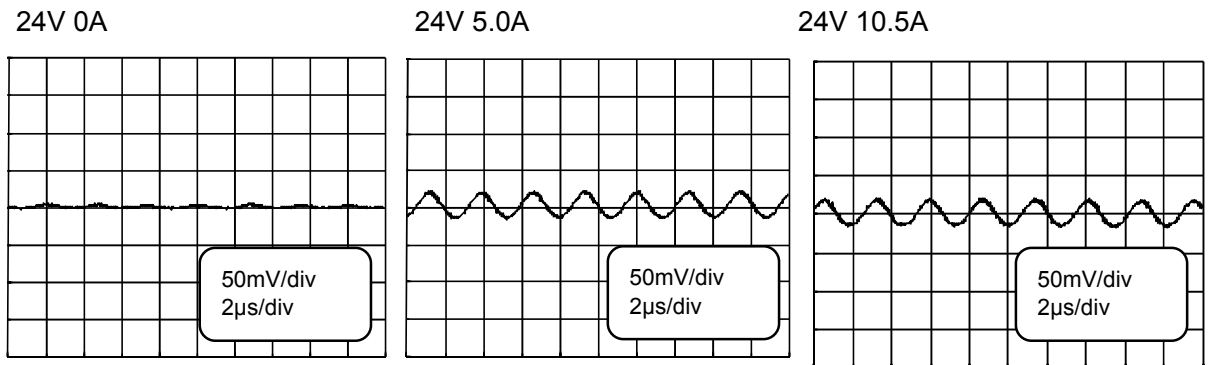

## 11 Thermal Considerations

- To ensure operation of power module, it is necessary to keep baseplate temperature within the allowable temperature limit. The reliability of the power module depends on the temperature of the baseplate. In order to obtain maximum reliability, keep the aluminum base plate temperature low.
- Proper thermal design makes higher MTBF, smaller size and lower costs.

### 11.1 Efficiency and Dissipation power

- Not all of the input power is converted to output power, some loss is dissipated as heat power module inside. To determine the internal power dissipation, give 1 - 2 % margin of the efficiency value which is calculated by Characteristics of Efficiency vs. Output current.
- Efficiency is defined as percentage of Output power vs Input power. Efficiency (E) depends on input voltage and output current. Refer to the individual data.

Fig. 11.1  
Internal power  
dissipated

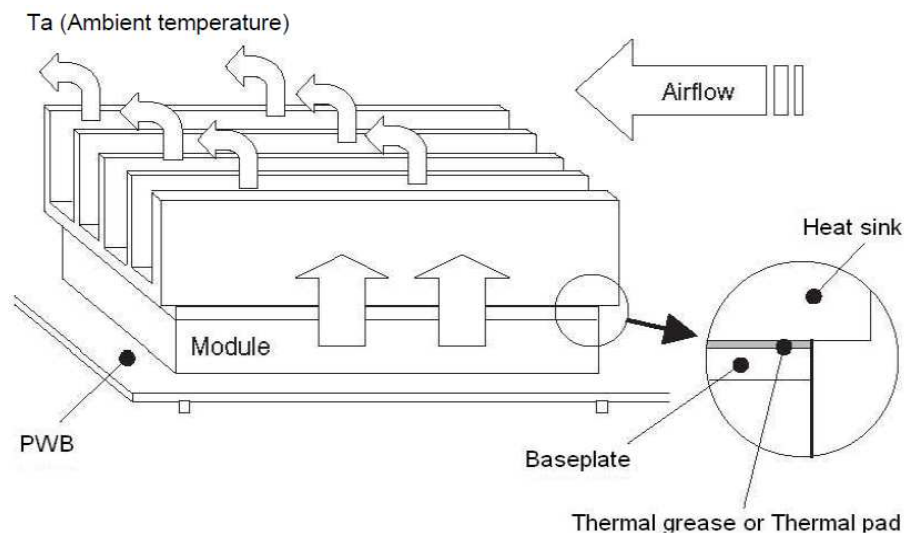

$$P_{in} = V_{in} \times I_{in}$$

$$P_{out} = V_{out} \times I_{out}$$

$$\eta = \frac{P_{out}}{P_{in}} \times 100$$

$$P_d = \frac{1 - \eta}{\eta} \times P_{out}$$

$P_{in}$  : Input power (W)

$P_{out}$  : Output power (W)

$P_d$  : Internal power dissipated (W)

$\eta$  : Efficiency (%)

## 11.2 Thermal resistance

- In most applications, heat will be conducted from the baseplate into an attached heat sink. Heat conducted across the interface between the baseplate and heat sink will result in a temperature drop which must be controlled. As shown in Fig.8.3.1, the interface can be modeled as a thermal resistance' with the dissipated power flow.

Fig. 11.2  
Thermal resistance

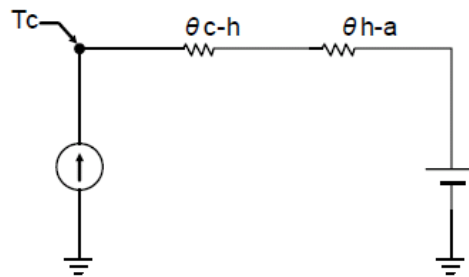

The thermal resistance of heat sink is calculated by following equation.

$$\theta_{h-a} = \frac{T_c - T_a}{P_d} - \theta_{c-h}$$

- $\theta_{h-a}$  : Thermal resistance of Heat sink ( $^{\circ}\text{C}/\text{W}$ ) (Heat sink - Air)
- $\theta_{c-h}$  : Contact thermal resistance ( $^{\circ}\text{C}/\text{W}$ ) (Baseplate - Heat sink)
- $P_d$  : Internal power dissipated (W)
- $T_c$  : Baseplate temperature ( $^{\circ}\text{C}$ )
- $T_a$  : Ambient temperature ( $^{\circ}\text{C}$ )

- Contact thermal resistance is between baseplate and heat sink. To decrease the contact thermal resistance, use thermal grease and thermal pad. When using thermal grease, apply in a uniform thin coat.

The thermal grease and thermal pad have the following respective features.

- (1) Thermal grease : low thermal resistance ( $0.2 - 0.3^{\circ}\text{C}/\text{W}$ ).
- (2) Thermal pad. : higher than thermal grease ( $0.3 - 0.4^{\circ}\text{C}/\text{W}$ ).

## 11.3 Efficiency vs output current

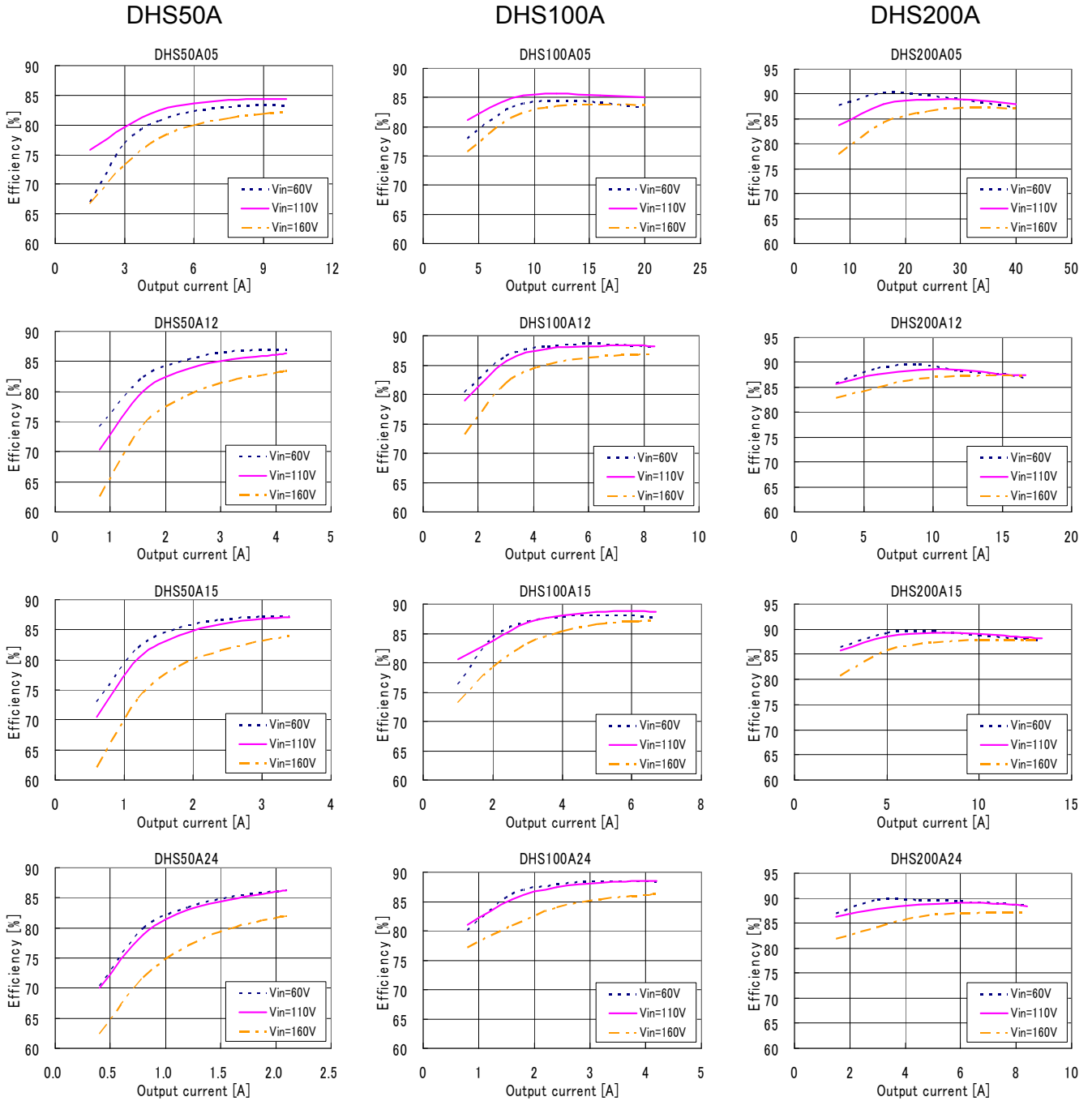

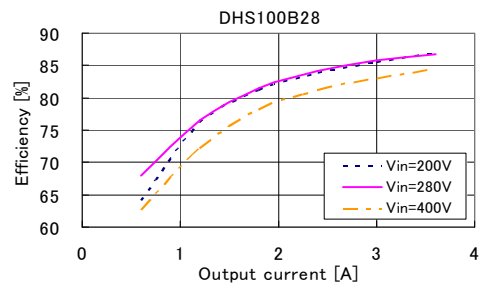
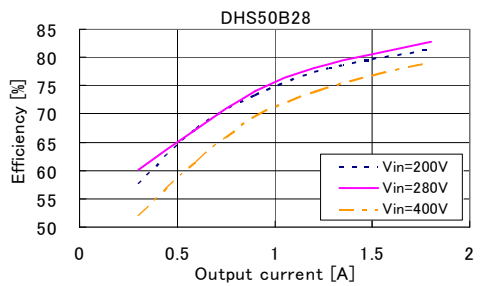
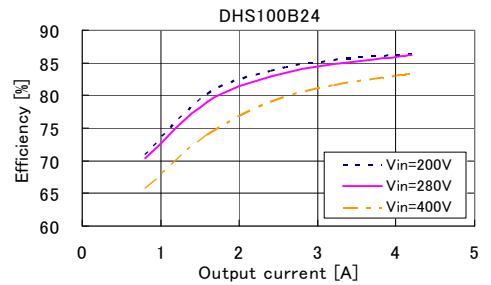
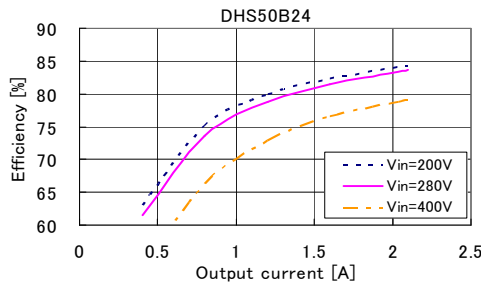
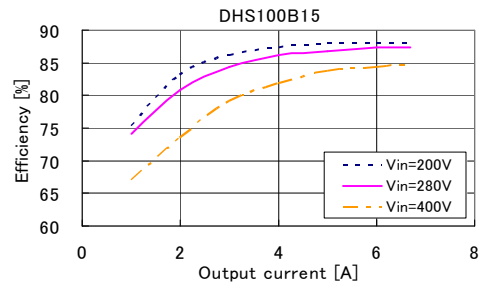
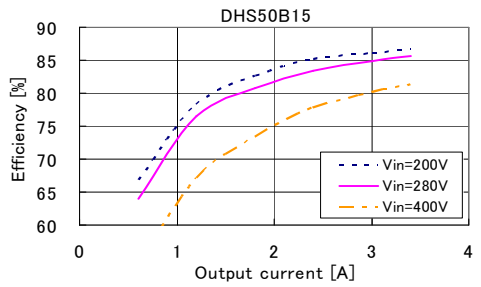
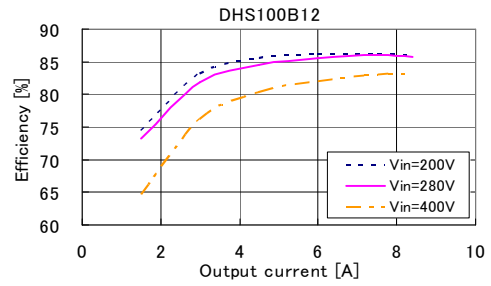
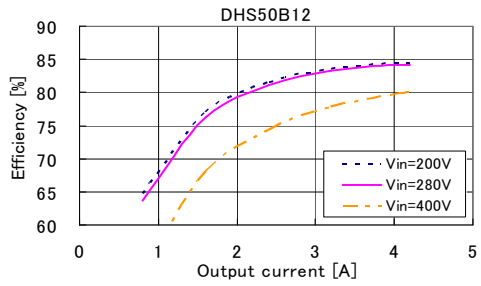
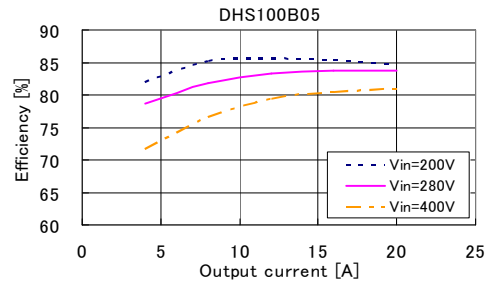
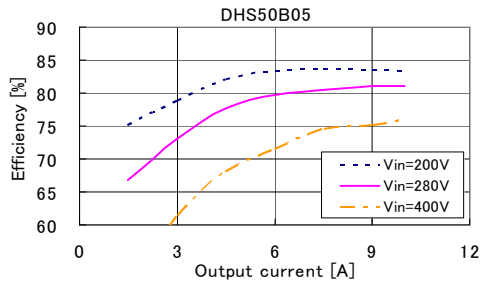
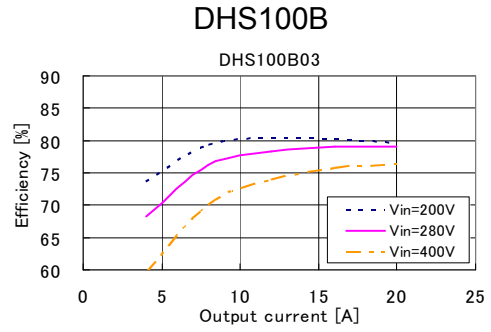
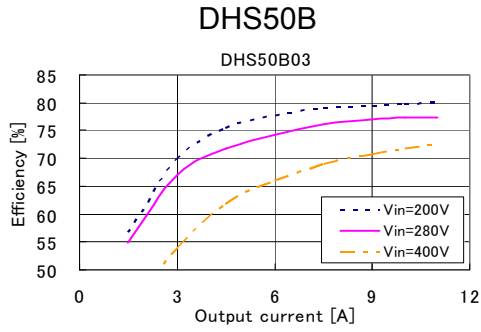

## DHS250B

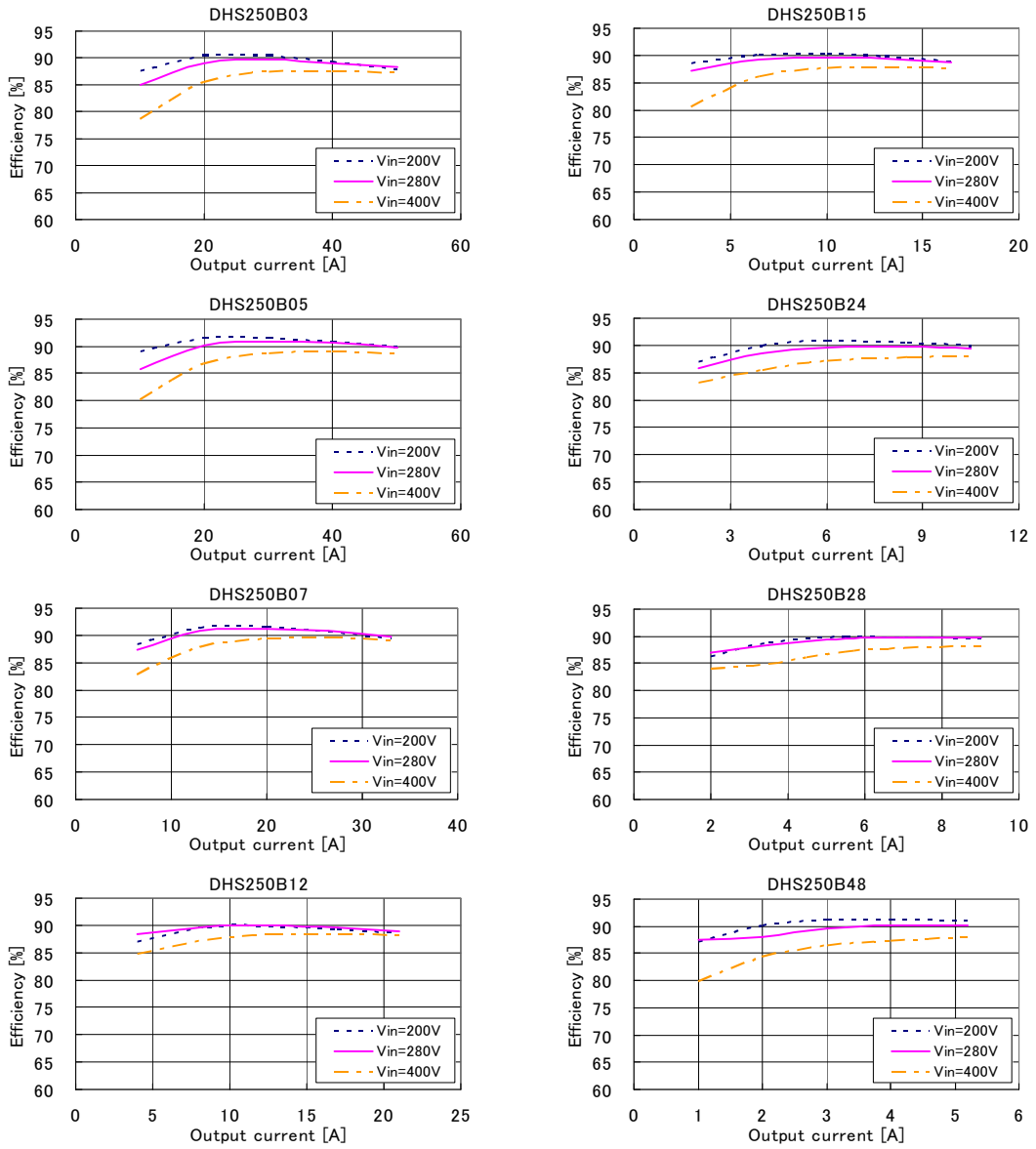

## 11 Derating

### 11.1 Cooling

- Use with the conduction cooling (e.g. heat radiation by conduction from the aluminum base plate to the attached heat sink).
- Fig. 11.1 shows the derating curve based on the aluminum base plate temperature. In the hatched area, the specification of ripple and ripple noise is different from other areas.
- The aluminum base plate temperature can be measured at point A or point B.  
In case of point B, please take 5deg temperature margin from the derating characteristic of Fig. 11.1.

Fig. 11.1  
Derating curve

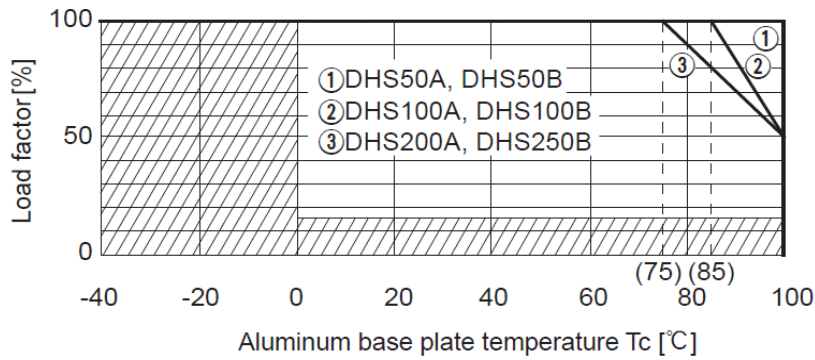
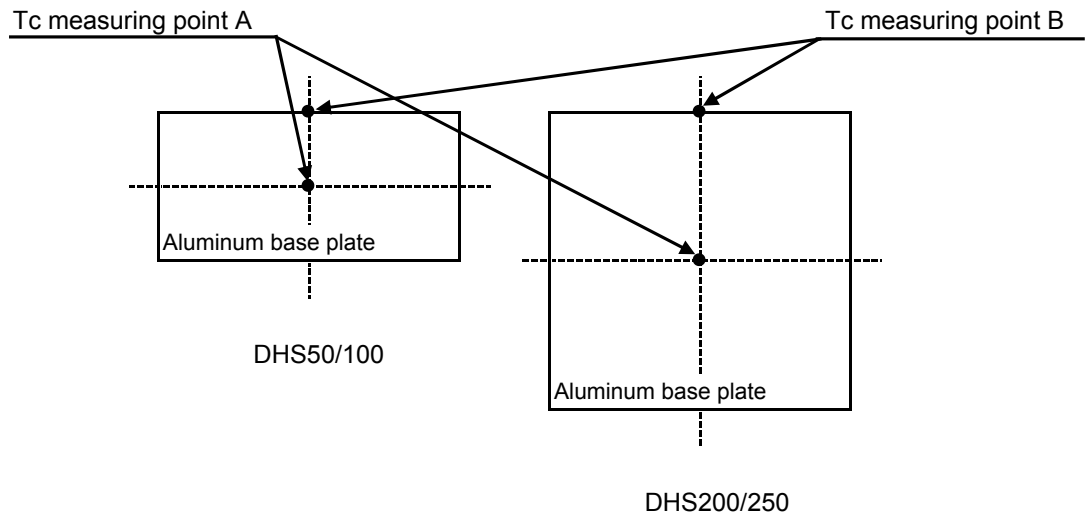

Fig. 11.2  
Measuring point



## 12 Thermal curve

Shown the Thermal curve with measuring environment as shown below.  
Verify final design by actual temperature measurement.

### 12.1 Measuring environment

Fig. 12.1  
Measuring environment

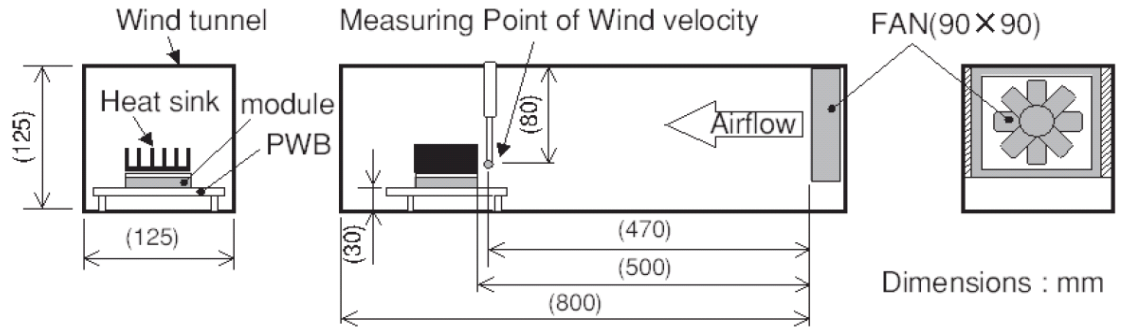
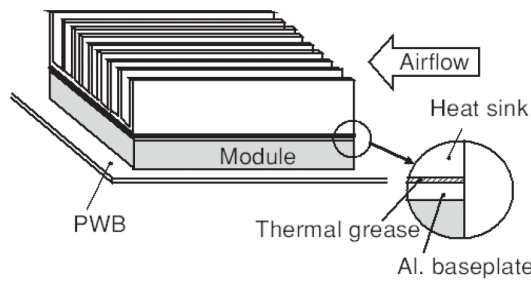

Fig. 12.2  
Measuring method



■ Example

Conditions Load factor : 80 [%]

Ambient temperature : 60 [°C]

Shown in Fig. 12.3, it is necessary to keep the wind velocity more than 1.0m/s. Refer to 12.2 Thermal Curves. Keep the baseplate temperature is lower than its derating curve temperature.

Refer to 11.1 Baseplate temperature

Measure the baseplate temperature at the center of the baseplate

Fig. 12.3  
Example of Thermal curves

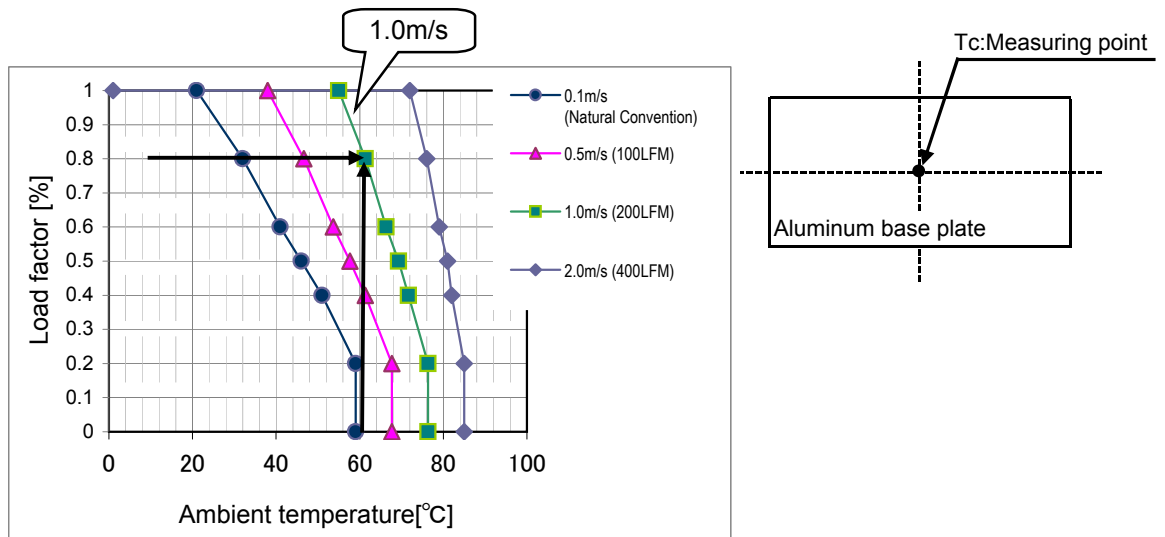

## 12.2 Thermal curves

### DHS50A05

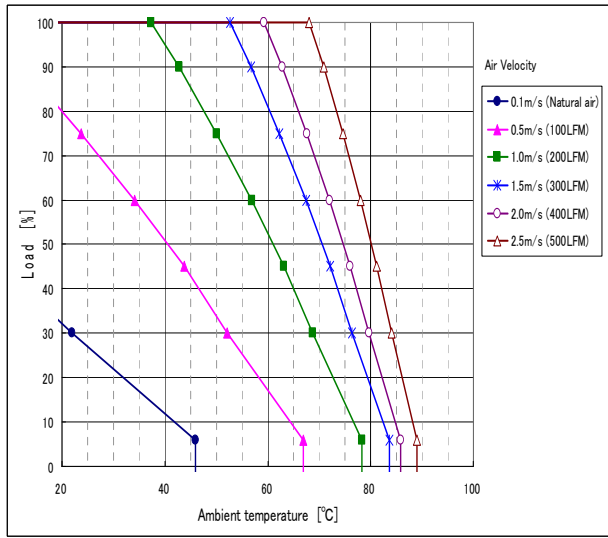

F-QB-F1/F2 (H = 12.7mm)

### DHS50A12/15/24

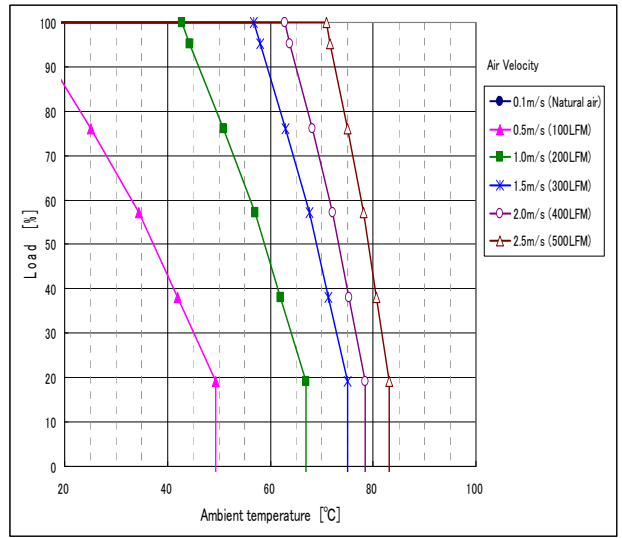

F-QB-F1/F2 (H = 12.7mm)

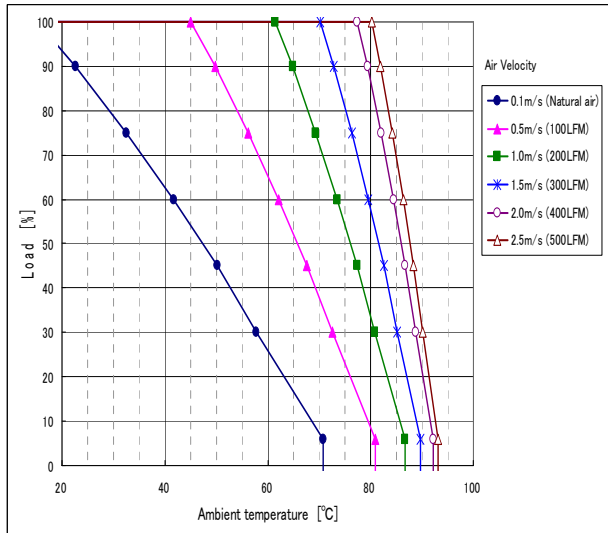

F-QB-F3/F4 (H = 25.4mm)

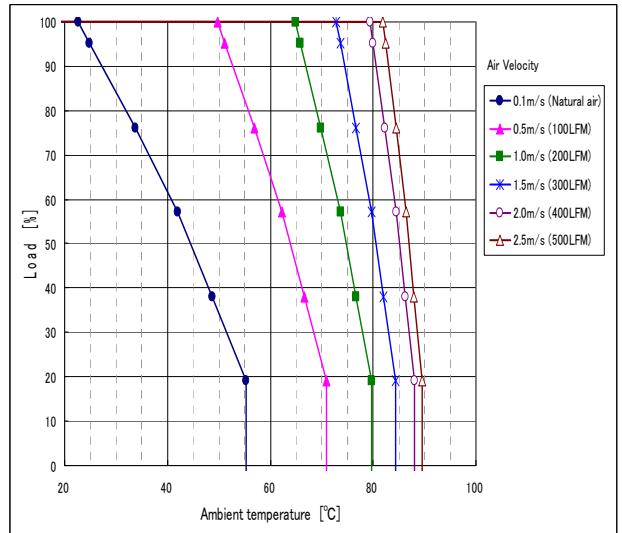

F-QB-F3/F4 (H = 25.4mm)

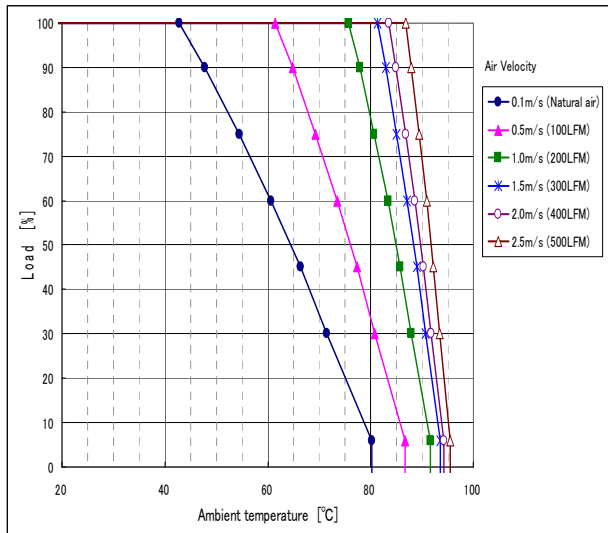

F-QB-F5/F6 (H = 25.4mm)

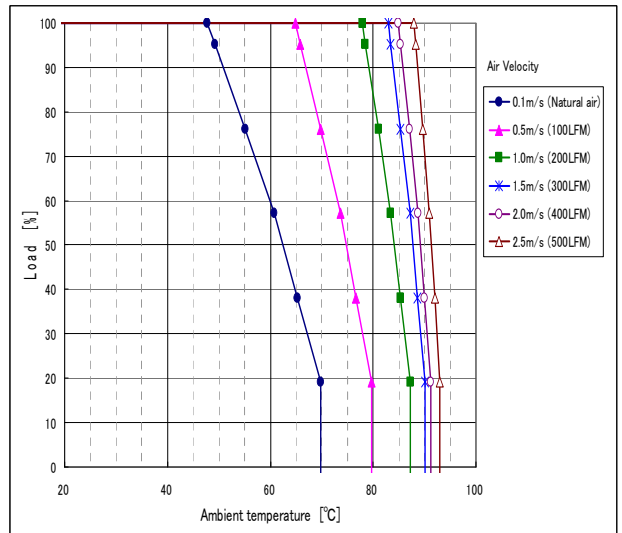

F-QB-F5/F6 (H = 25.4mm)

## DHS100A05

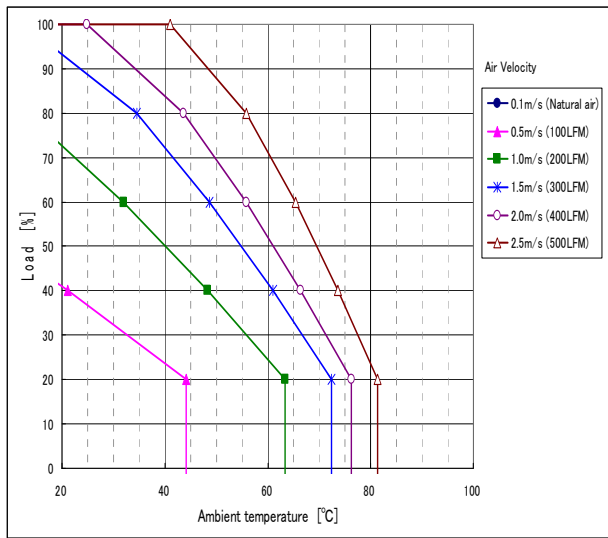

F-QB-F1/F2 (H = 12.7mm)

## DHS100A12/15/24

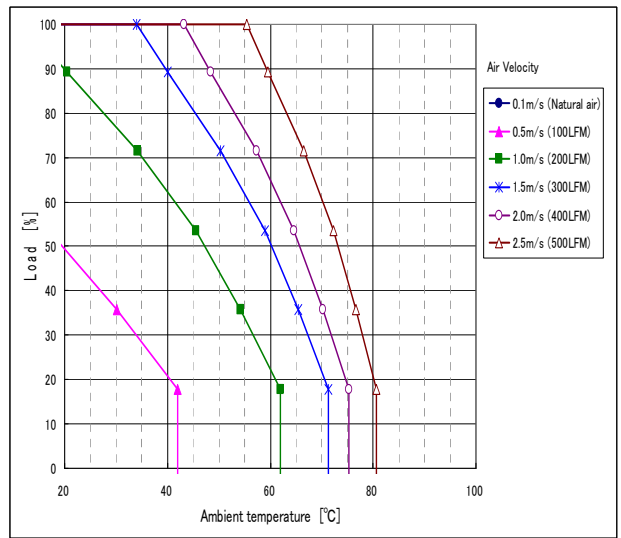

F-QB-F1/F2 (H = 12.7mm)

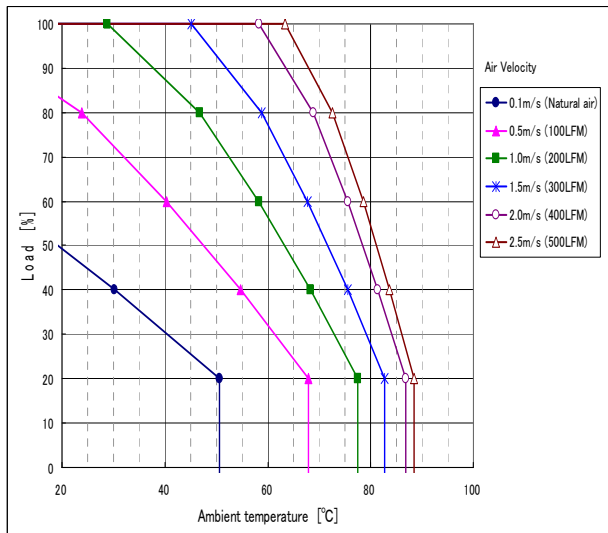

F-QB-F3/F4 (H = 25.4mm)

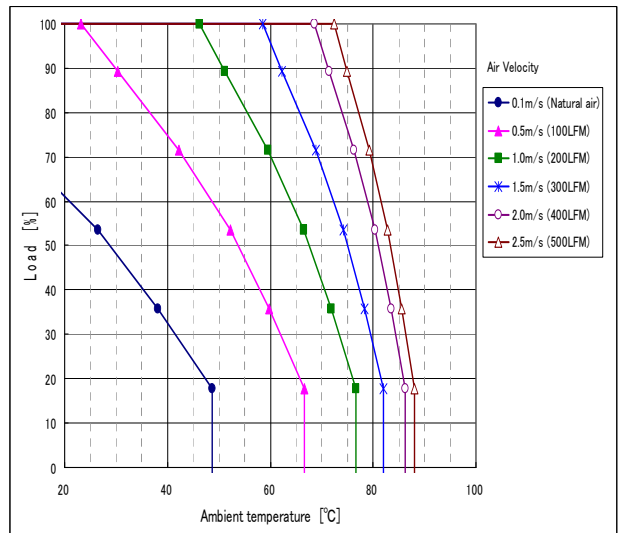

F-QB-F3/F4 (H = 25.4mm)

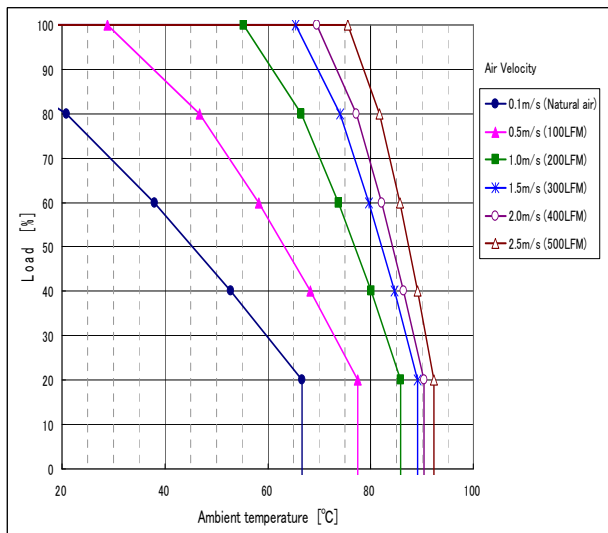

F-QB-F5/F6 (H = 25.4mm)

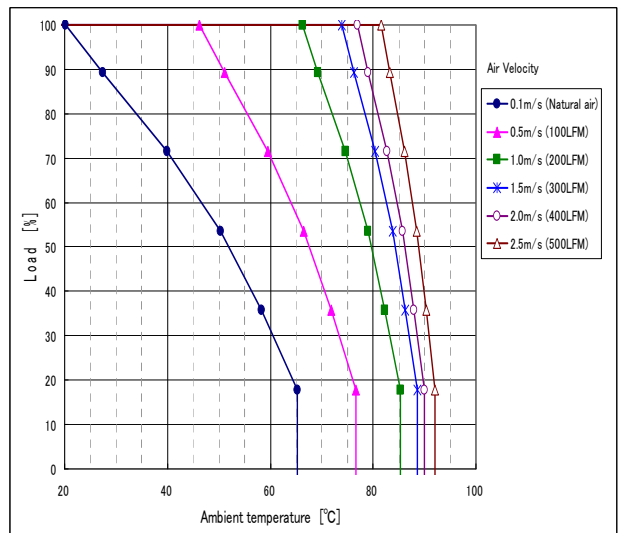

F-QB-F5/F6 (H = 25.4mm)

## DHS200A05

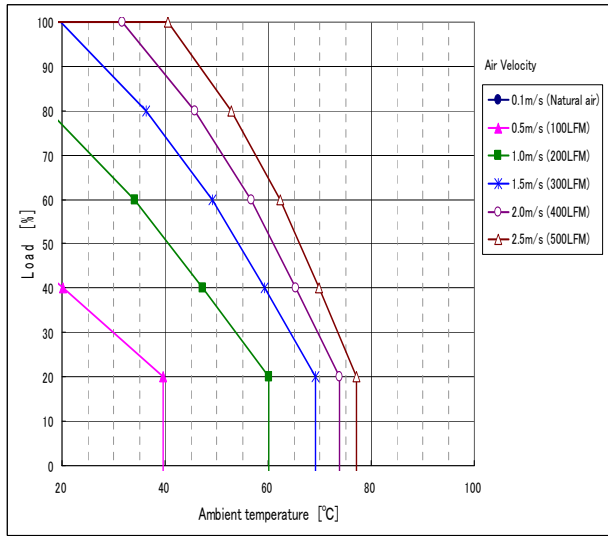

F-CBS-F1/F2 (H = 12.7mm)

## DHS200A12/15/24

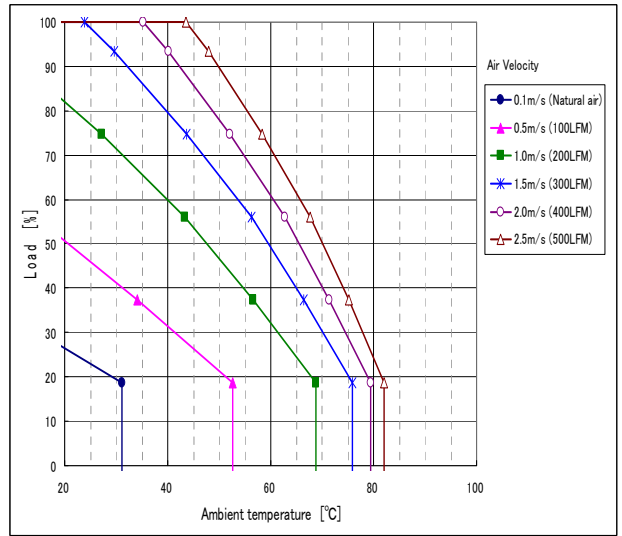

F-CBS-F1/F2 (H = 12.7mm)

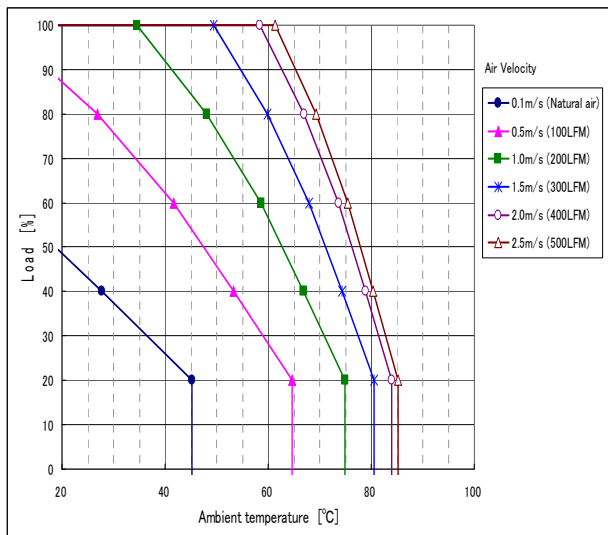

F-CBS-F3/F4 (H = 25.4mm)

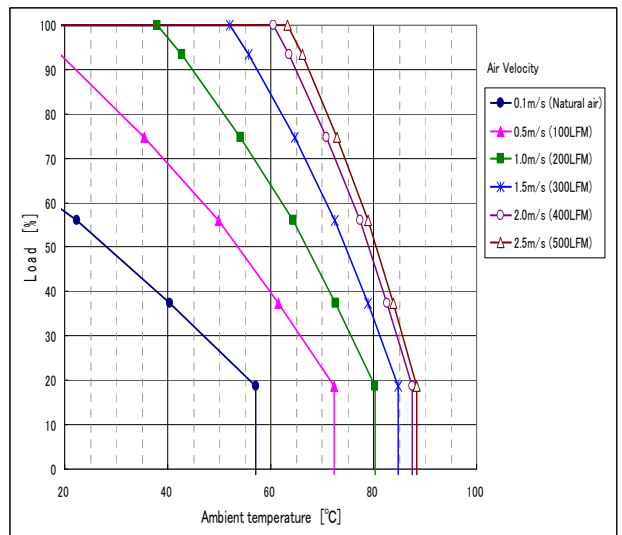

F-CBS-F3/F4 (H = 25.4mm)

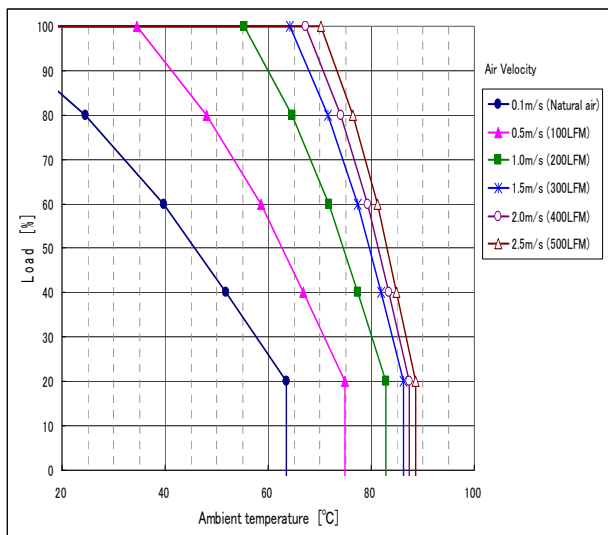

F-CBS-F5/F6 (H = 25.4mm)

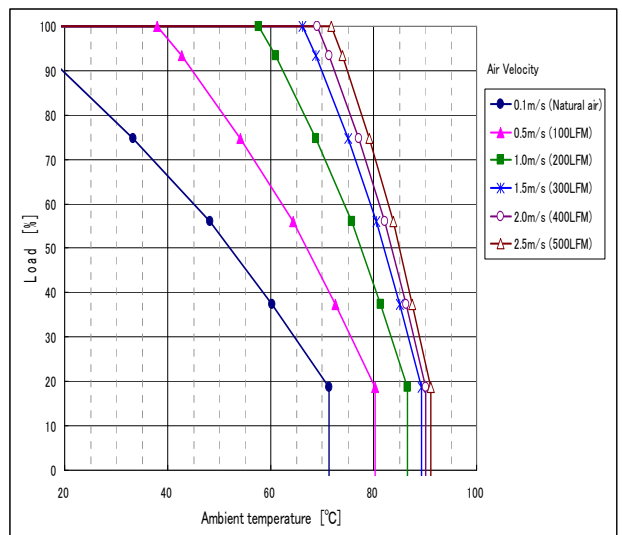

F-CBS-F5/F6 (H = 25.4mm)

## DHS50B03/05

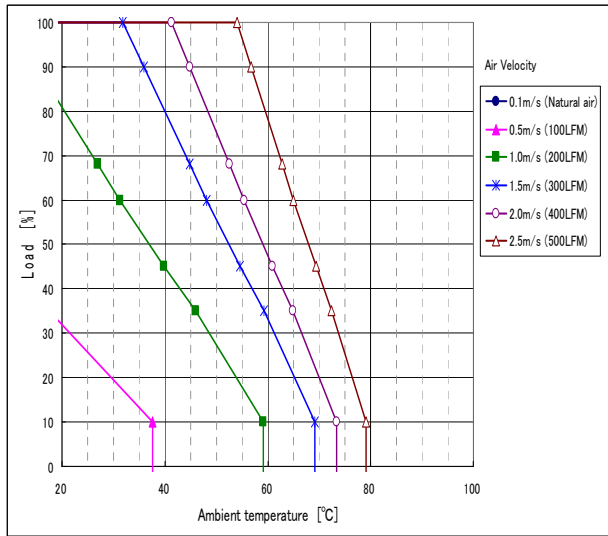

F-QB-F1/F2 (H = 12.7mm)

## DHS50B12/15/24/28

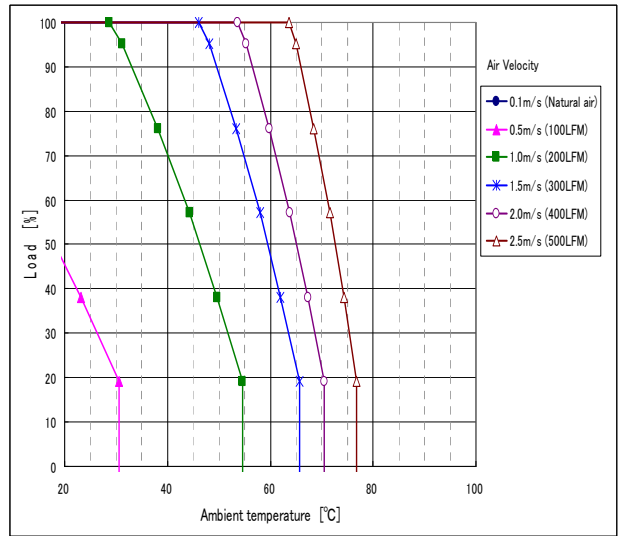

F-QB-F1/F2 (H = 12.7mm)

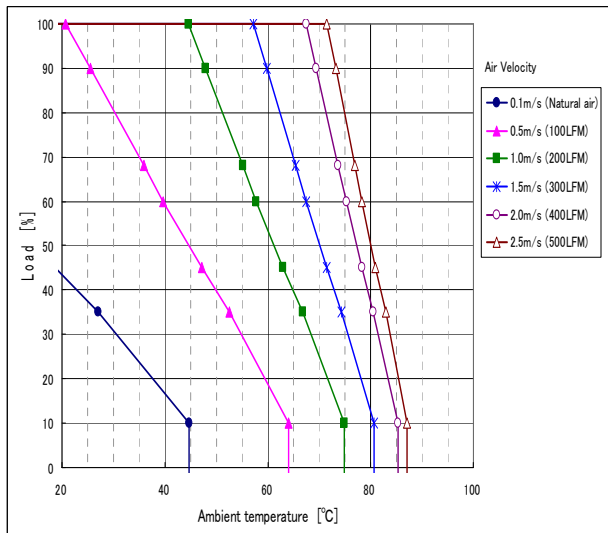

F-QB-F3/F4 (H = 25.4mm)

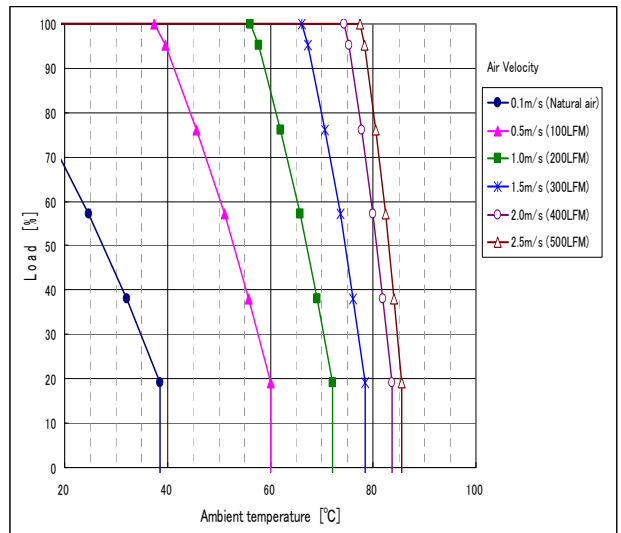

F-QB-F3/F4 (H = 25.4mm)

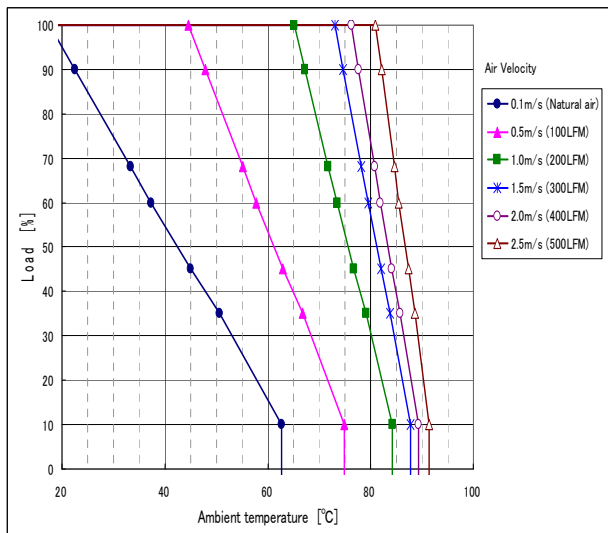

F-QB-F5/F6 (H = 25.4mm)

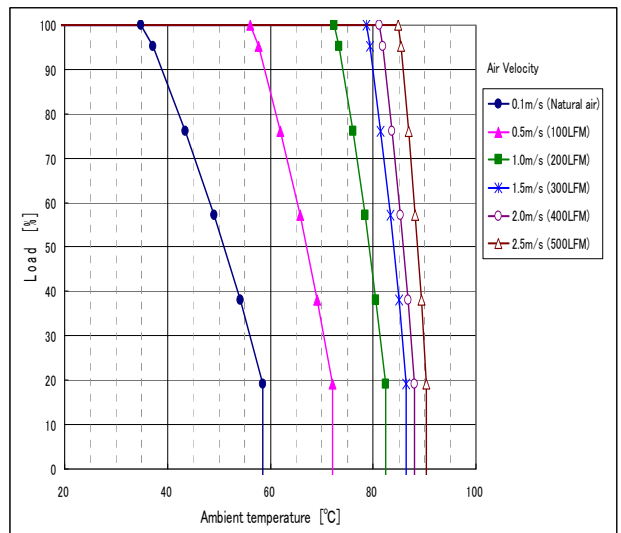

F-QB-F5/F6 (H = 25.4mm)

## DHS100B03/05

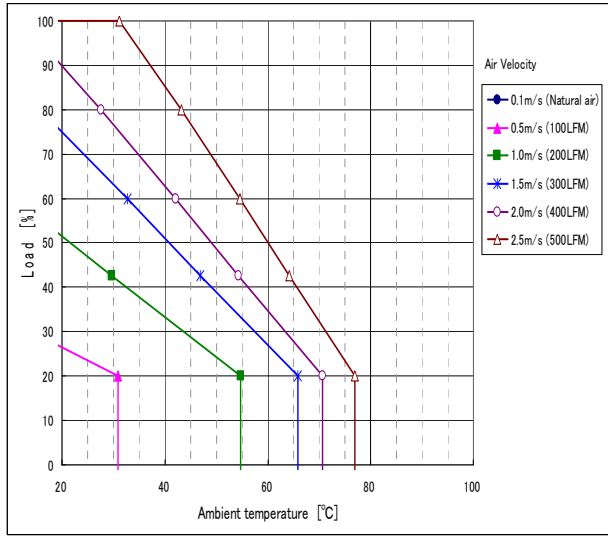

F-QB-F1/F2 (H = 12.7mm)

## DHS100B12/15/24/28

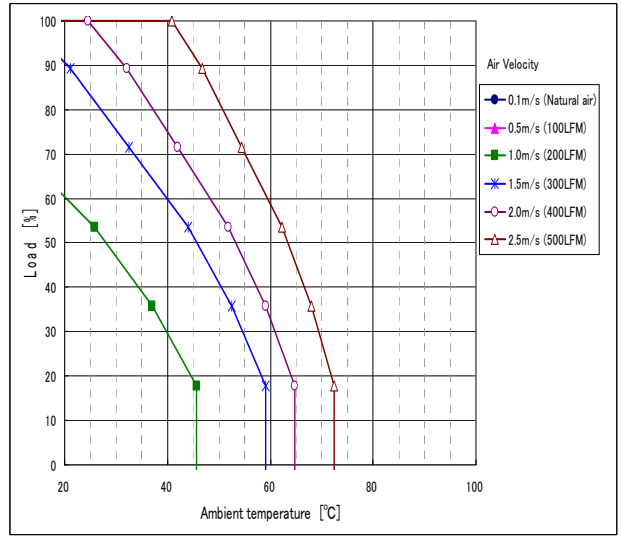

F-QB-F1/F2 (H = 12.7mm)

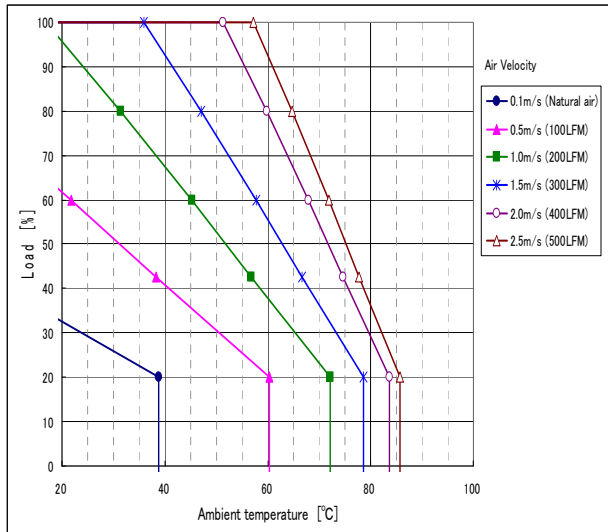

F-QB-F3/F4 (H = 25.4mm)

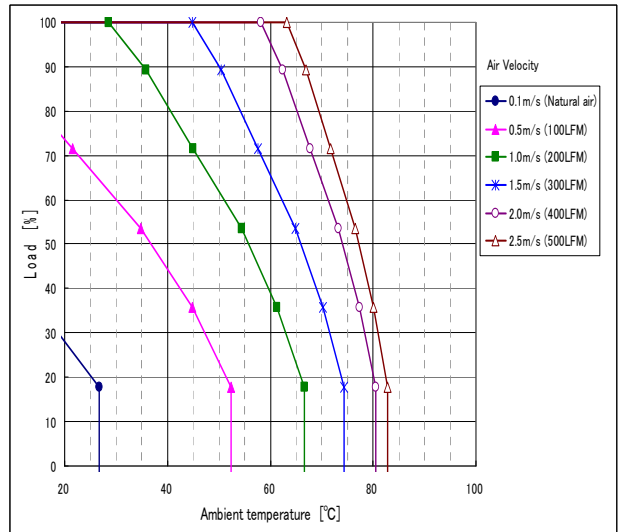

F-QB-F3/F4 (H = 25.4mm)

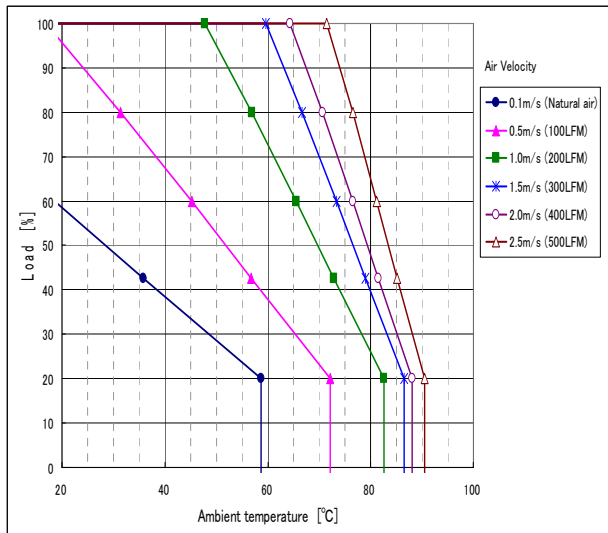

F-QB-F5/F6 (H = 25.4mm)

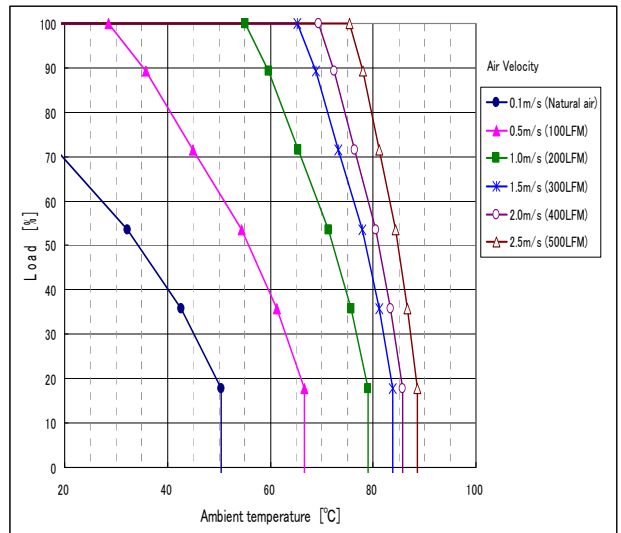

F-QB-F5/F6 (H = 25.4mm)

DHS250B03/05/07

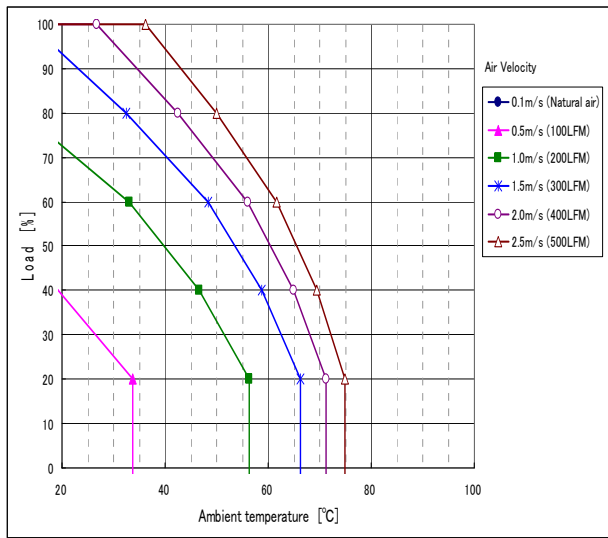

F-CBS-F1/F2 (H = 12.7mm)

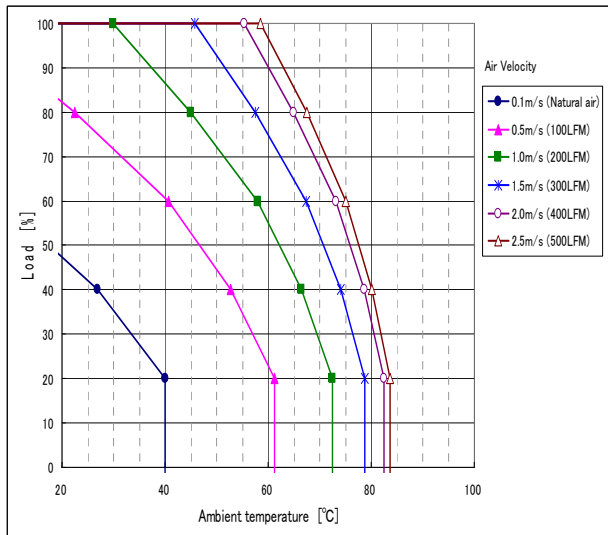

F-CBS-F3/F4 (H = 25.4mm)

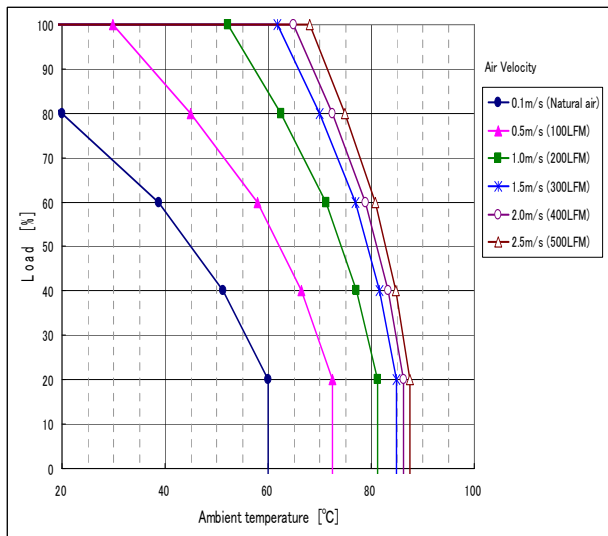

F-CBS-F5/F6 (H = 25.4mm)

DHS250B12/15/24/28/48

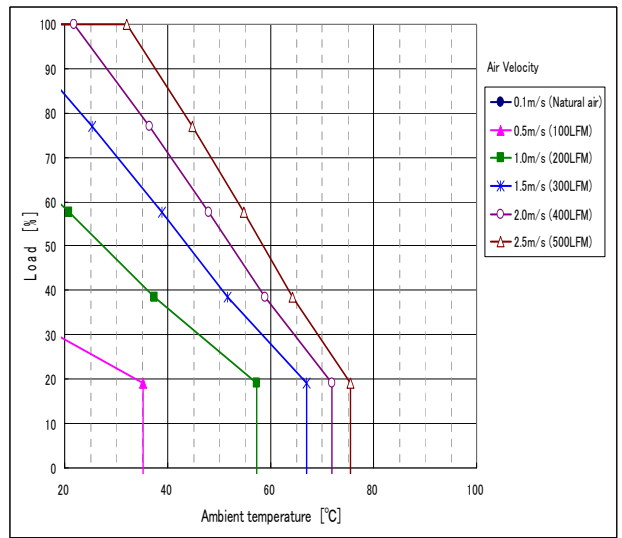

F-CBS-F1/F2 (H = 12.7mm)

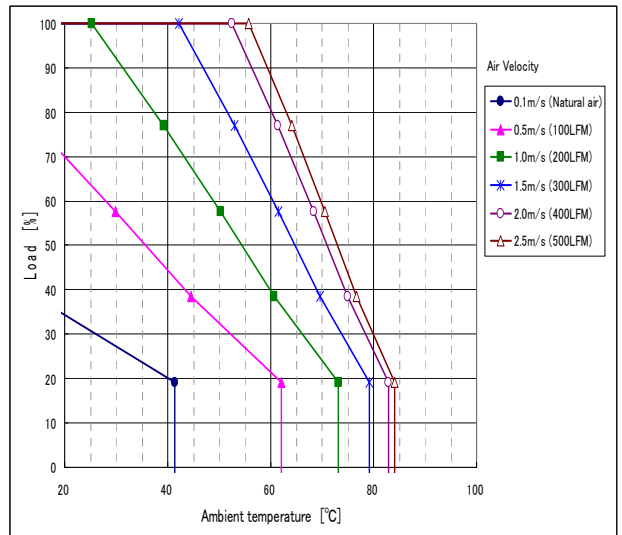

F-CBS-F3/F4 (H = 25.4mm)

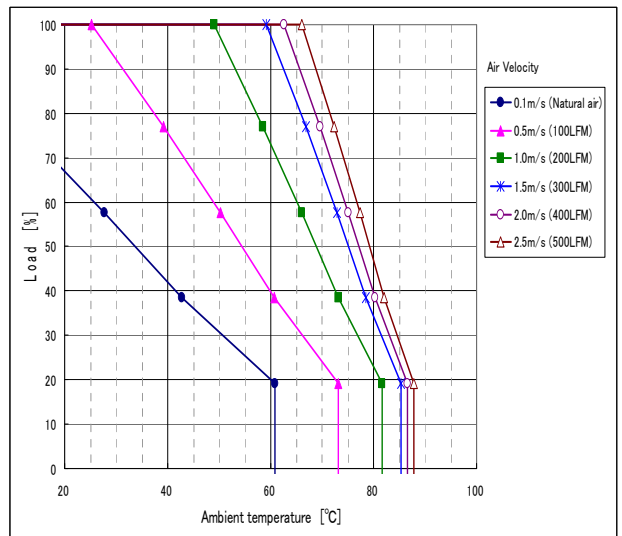

F-CBS-F5/F6 (H = 25.4mm)

## 13 Heat sink size and Thermal resistance

### ■ Quarter Brick size

Heat sink is prepared in DHS series Optional Parts.

Chart : List of Heat sink for DHS50/100 series

No.	Model	Size[mm]			Thermal resistance[°C/W]		Style
		H	W	D	Convection (0.1m/s)	Force Air	
1	F-QB-F1	12.7	58.4	37.6	14.0	Refer Fig.1.1.1	Horizontal
2	F-QB-F2	12.7	58.7	37.3			Vertical
3	F-QB-F3	25.4	58.4	37.6	7.5		Horizontal
4	F-QB-F4	25.4	58.7	37.3			Vertical
5	F-QB-F5	38.1	58.4	37.6	5.0		Horizontal
6	F-QB-F6	38.1	58.7	37.3			Vertical



図1 F-QB-F1の外形図



図2 F-QB-F3の外形図

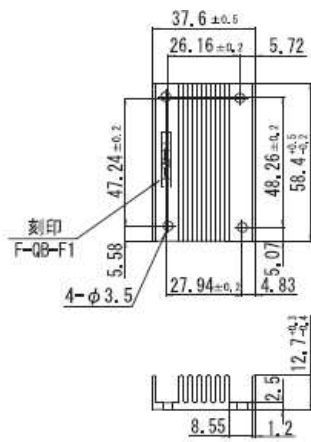

図3 F-QB-F5の外形図

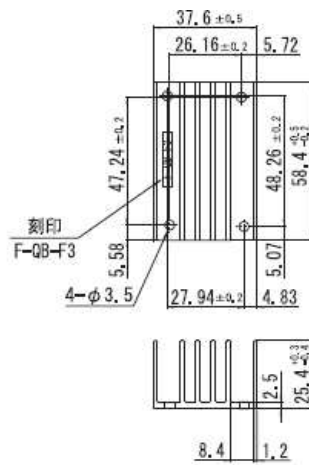

図4 F-QB-F2の外形図

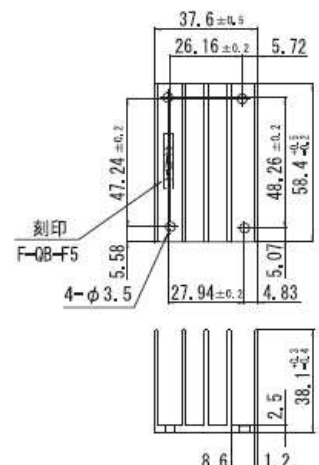

図5 F-QB-F4の外形図

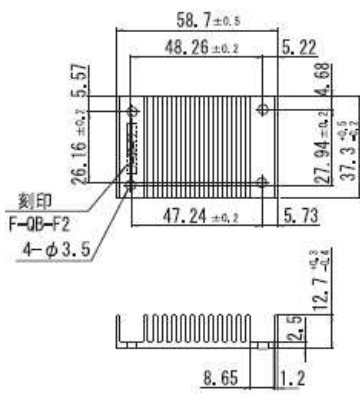

図6 F-QB-F6の外形図

Fig. 13.1  
Heat sink thermal  
resistance curve

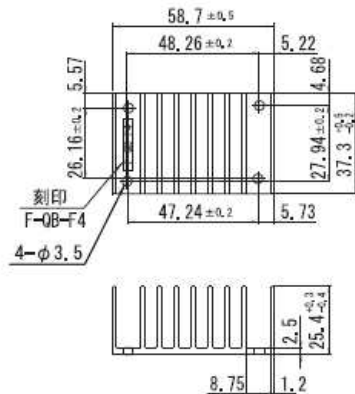

■ Half Brick size

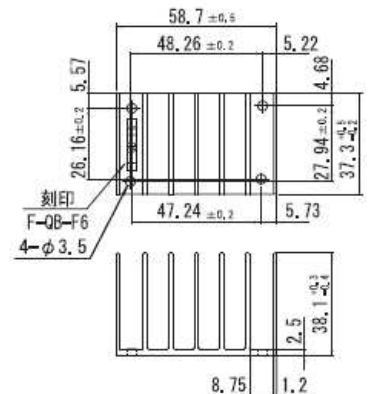
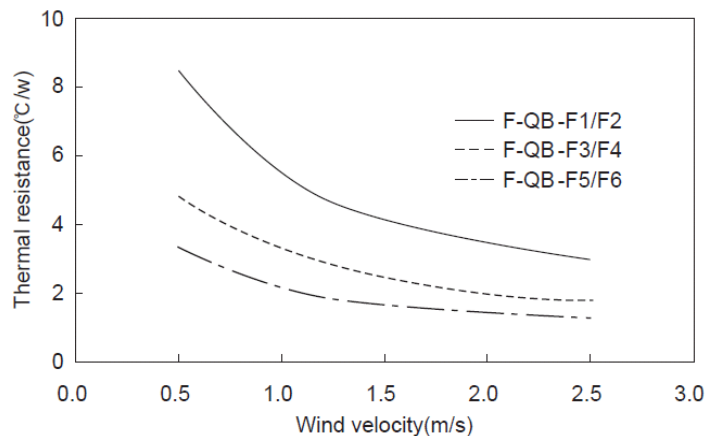
Heat sink is prepared in DHS series Optional Parts.

Chart : List of Heat sink for DHS200/250 series

No.	Model	Size[mm]			Thermal resistance[°C/W]		Style
		H	W	D	Convection (0.1m/s)	Force Air	
1	F-CBS-F1	12.7	57.9	61.5	7.5	Refer Fig.1.1.1	Horizontal
2	F-CBS-F2	12.7	58.4	61.0			Vertical
3	F-CBS-F3	25.4	57.9	61.5	4.6		Horizontal
4	F-CBS-F4	25.4	58.4	61.0			Vertical
5	F-CBS-F5	38.1	57.9	61.5	3.0		Horizontal
6	F-CBS-F6	38.1	58.4	61.0			Vertical

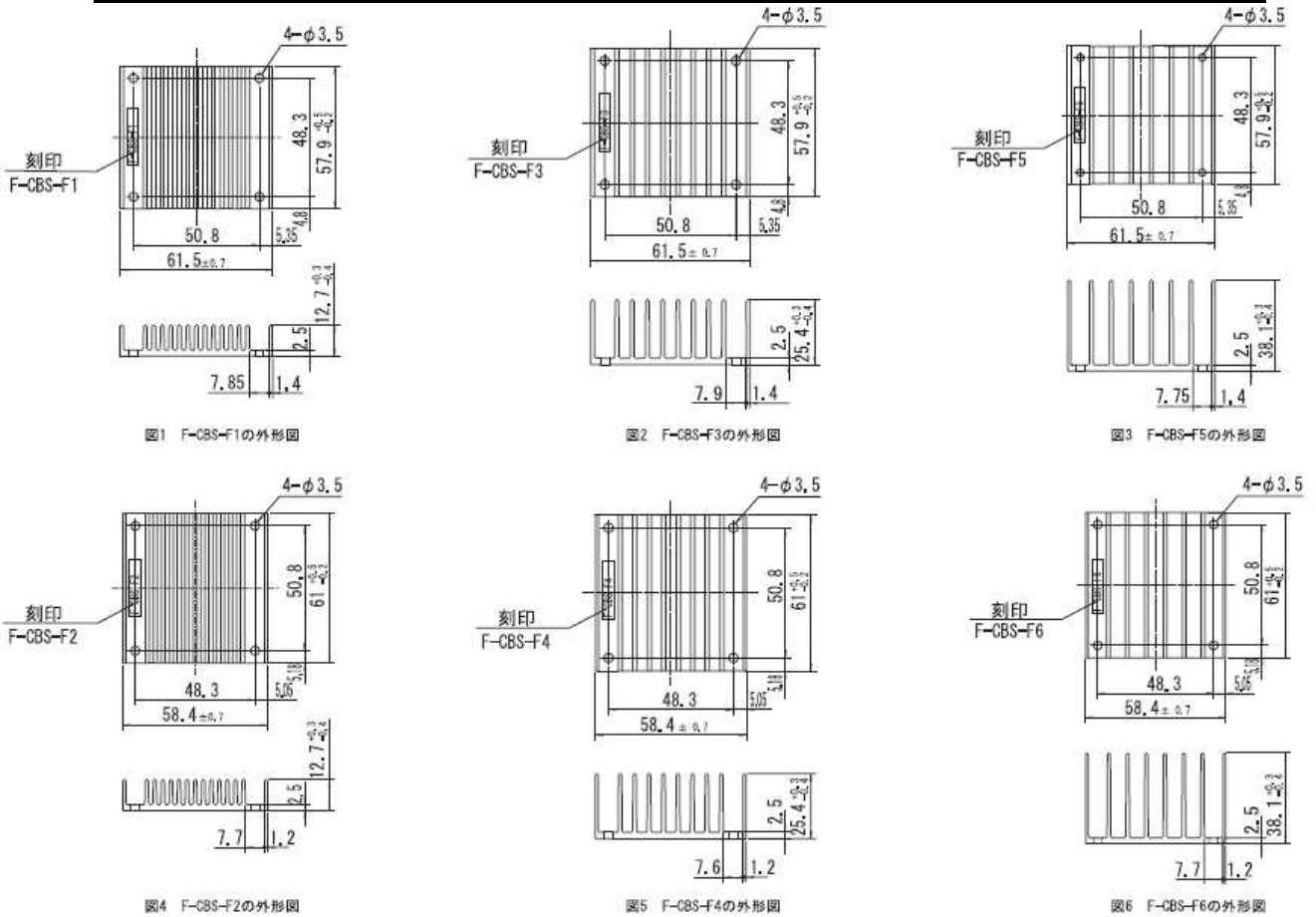

Fig.1.6.1  
Heat sink thermal  
resistance curve

